

Prentice-Hall International, Inc., London
Prentice-Hall of Australia, Pty. Ltd., Sydney
Prentice-Hall of Canada, Ltd., Toronto
Prentice-Hall of India Private Ltd., New Delhi
Prentice-Hall of Japan, Inc., Tokyo

© 1973, by

PRENTICE-HALL, INC.

Englewood Cliffs, N.J.

*All rights reserved. No part of this
book may be reproduced in any form or
by any means, without permission in
writing from the publisher.*

"This publication is designed to provide accurate and authoritative information in regard to the subject matter covered. It is sold with the understanding that the publisher is not engaged in rendering legal, accounting, or other professional service. If legal advice or other expert assistance is required, the services of a competent professional person should be sought.

... From the Declaration of Principles jointly adopted by a Committee of the American Bar Association and a Committee of Publishers and Associations."

Library of Congress Cataloging in Publication Data

Garrett, William C

Investing for profit with torque analysis of stock market cycles.

Includes bibliographical references.

1. Stock price forecasting. 2. Stocks.

I. Title.

HG4636.G37 332.61322 73-3404

ISBN 0-13-502625-3

Printed in the United States of America



abcBourse.ir



@abcBourse_ir

مرجع آموزش بورس



باز نشر:



Photo by Irving Rosen Photography

About the Author

Like a lot of other people, Mr. Garrett bought his first stocks at a market high—in 1957—and promptly saw them deteriorate. Since these stocks were highly recommended and had “good stories,” it was obvious that more than someone else’s opinion was needed.

This experience led him, first, to technical analysis, then to fundamental analysis and, finally, to the development of cyclical analysis methods. The last inquiry was spurred by introduction in the early 1960s of the controversial “random walk” theory with which he disagreed because technical analysis of stock charts indicated there was an orderly progression of prices in the market.

What was missing, he decided, was an understanding of the underlying system of price progressions. Ten years later, after thousands of hours studying charts and making calculations, his TORQUE ANALYSIS methods revealed that there were identifiable cycles in the market and that their effect on prices could be measured.

Before becoming a stockbroker in 1965, Mr. Garrett was a journalist by profession with a smattering of engineering knowledge thrown in. He studied engineering at Iowa State University and journalism at the University of Missouri. He served in the tank destroyers in World War II and afterward joined the editorial staff of the Honolulu Star-Bulletin, later becoming city editor. He was called back to service in the Korean conflict, and, on return, joined the advertising staff of the paper, resigning as retail advertising manager in 1961 to spend full time studying the market. He is currently a stockbroker with Walston & Co. in Honolulu.



How You Can Profit from a Knowledge of Stock Market Cycles

How much should you pay for a stock?

With the cyclical analysis principles illustrated in this book, there are now two methods of arriving at the answer, each of which supplements the other, which is reasonable because stock prices consist of not one but two parts: earnings (intrinsic) value and cyclical (market) worth.

By fundamental analysis, we can determine the earnings-value portion—or *the relatively stable intrinsic value* in a stock's price, expressed as a normal price/earnings ratio—and, from a projection of probable future earnings, the trend which future values are likely to follow.

By cyclical analysis, we can determine the cyclical-worth portion—or *the highly variable high and low market prices* likely to be paid as a premium for, or as a discount from, those fundamental values at future points in time. As a bonus, because of the proclivity of cycles to trough at about equal time intervals, cyclical analysis can also indicate *when* the alternating high and low market price levels are likely to be reached.

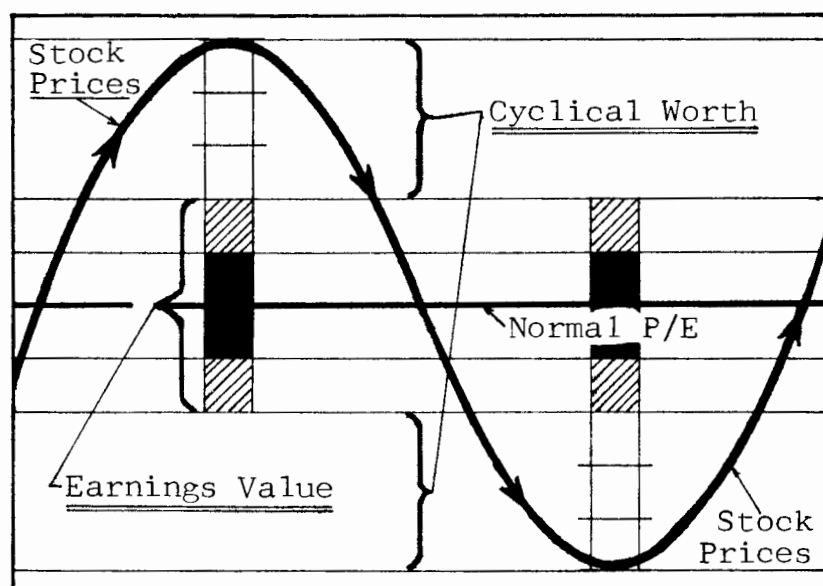

Cyclical analysis is concerned with measurement and assessment of the rhythmic fluctuations of market price above and below intrinsic values. It is based, first, on the determination of the TORQUE FACTOR—or the value of the force which cycles exert to push prices above fundamental values in an upward swing and pull prices below fundamental values in a downward swing of the cyclical rhythm—and, second, on the projection of cyclical rhythms into the future.

When we combine the two methods, we are able to assess future probabilities for price movement from (1) *the trendular direction* of intrinsic values, as indicated by fundamental or economic analysis, and (2) *the cyclical direction* of present and future price rhythms, as indicated by TORQUE ANALYSIS of the price cycles.

This book, then, has twin purposes: (1) To show you that cycles are real forces in the stock market and exert real and observable force in the movement of stock prices (causing, probably, more than half of the extent of a price swing). (2) To show you how to make your own appraisal of the probable timing and extent of future price swings. With this knowledge your profit performance should improve—if you can accept the idea that, with cycles, a trough is a prelude to an ensuing peak and not an indication of even lower prices, and that a peak is not an indication of even higher prices but of lower prices to come.

The book is written for the man who does not have access to a computer but who can do simple calculations on paper or, better, with a small calculator. You will understand the mathematical principles involved, since they are fully explained.

It is important to note, in this context, that profits derive from consistent gains and, only rarely, from a “killing.” Great oaks from little acorns grow—but the trees do not mature in a couple of days. They grow in surges from the successive thrusts of each springtime, or the upward thrusts of the annual cyclical rhythm.

The thrust of this book is that, with a little homework after you have the basic tables set up, you can easily determine for yourself (1) the trendular or long-term direction of price by analysis of the longer cycles, and by fundamental analysis, (2) the cyclical or short-term direction of price by analysis of the short cycles and (3) *when* both types of cyclical movement are likely to be concluded and reverse in the opposite direction. When you couple this knowledge of timing and extent with fundamental analysis, you should be able to show consistent profits in the stock market because you will be able to “see through” surface indications and judge for yourself the flow of the basic currents underlying stock price movements.

—Bill Garrett



List of Illustrations



FIGURES

Figure 1.1	— Transaction-by-transaction chart of the trading in Occidental Petroleum on Monday, November 20, 1967	30
Figure 1.2	— Transaction-by-transaction chart of the trading in Fairchild Camera on Monday, November 20, 1967	31
Figure 1.3	— Four of the five harmonic-length cycles of the market. In addition to those shown, a cycle of two weeks is also present in the harmonic pattern	35
Figure 1.4	— Transaction-by-transaction chart of trading in City Investing on Monday, December 4, 1967	36
Figure 1.5	— The Dow Jones industrial average of 30 stocks in the latter part of 1967 .	37
Figure 1.6	— A synthesis of two cycles	39
Figure 1.7	— A synthesis of five principal market cycles, combining the 10-day, 10-week, 25-week, 75-week and 225-week cycles	40
Figure 1.8	— The Dow Jones industrial average, monthly high-low closing prices, from the beginning in January 1897 through 1915	45
Figure 1.9	— The Dow Jones industrial average during the 17-year cycle, 1915–32 . . .	46
Figure 1.10	— The Dow Jones industrial average from the 1932 bottom to the beginning of the next 17-year cycle, 1949	47
Figure 1.11	— The Dow Jones industrial average in the 1949–66 period of the 17-year cycle	48
Figure 1.12	— Weekly basis high-low chart of the Dow industrial average during the 4.25-year cycle, 1958–62	51
Figure 1.13	— Weekly basis high-low chart of the Dow industrial average and the 4.25-year cycle, 1928–32	54
Figure 1.14	— The 4.25-year cycle, 1897–1902. Weekly basis high-low closing prices of the Dow industrial average	56

Figure 1.15 — The Dow industrial average in the second half of the double cycle 1902–07	58
Figure 2.1 — A schematic drawing of the market's cyclical field of force	65
Figure 2.2 — The Dow industrial average and a 12-month moving total of NYSE volume, 1897–1916	74
Figure 2.3 — The Dow industrial average and a 12-month moving total of NYSE volume, 1914–33	75
Figure 2.4 — The Dow industrial average and a 12-month moving total of NYSE volume, 1931–50	76
Figure 2.5 — The Dow industrial average and a 12-month moving total of NYSE volume, 1948–67	77
Figure 2.6 — Quarterly-basis history of the Dow industrial average and NYSE volume, 1907–71	80
Figure 2.7 — How to build the Golden Rectangle of the Fibonacci series by movement of an axis	86
Figure 2.8 — How cycles grow from a thrust, a recoil and the Fibonacci (ϕ) additive ..	88
Figure 2.9 — How a cycle grows from a series of thrusts and recoils	89
Figure 2.10 — The mechanics of a thrust and a recoil—and how the Fibonacci control growth	91
Figure 3.1 — The effect of varying speeds of revolution on a single cycle	98
Figure 3.2 — The epicyclic arrangement of market cycles in a schematic drawing. The dashed curve represents volume buildup	102
Figure 3.3 — The Dow industrial average and volume moving totals in the 1929 runup of price	104
Figure 3.4 — The Dow industrial average and volume moving totals in two 4¼-year cycles, 1957–66	105
Figure 3.5 — The “randoms” of bank and broker margin calls carried the Dow average to new lows in May, 1970 from which it quickly recovered	115
Figure 3.6 — The effect on volume and price of the Dow average of two “randoms” of peace news in 1970	116
Figure 3.7 — Volume and price expressed as a percentage of 68-year monthly averages	118
Figure 3.8 — Price and volume averages by month in each of four 17-year cycle periods	120
Figure 4.1 — The right-angle relationship of advances to declines and of cycle radius and volume force	128



List of Illustrations	13
Figure 4.2 — The relationship of the A-Ds, volume and the price cycles of the market. Prices move as volume moves and are reflected on a price scale	129
Figure 4.3 — The method of dividing up-and-down “travel” of the Dow industrial average	133
Figure 4.4 — The price-volume relationships are easily seen in the movement of a single stock—Occidental Petroleum—during a day’s trading activity	134
Figure 4.5 — How placement of a moving total figure affects lag of the total ahead or behind the raw data	146
Figure 4.6 — The lag of moving totals against the 1970 background of the Dow average. The filtering action in moving totals	148
Figure 4.7 — The 39-week centered and end-formed moving totals in the 1971 down-slide of the Dow	149
Figure 4.8 — The relationship of the opposed couples of cyclical elements in five-day, 25-day and 65-day moving totals and of the Dow average	151
Figure 4.9 — The relationships of advances, the Dow industrial average and volume and buying volume show a variable correlation	155
Figure 4.10 — The division of the price factor by the volume factor brings out the TORQUE relationships in cycles in the market	160
Figure 4.11 — The movement of each of the five cycles during 1970	161
Figure 4.12 — The movement of each of the five cycles during 1966	163
Figure 4.13 — The movement of each of the five cycles during 1967	165
Figure 4.14 — The movement of each of the five cycles during 1968	166
Figure 4.15 — The movement of each of the five cycles during 1969	167
Figure 5.1 — The parabolic shape of market price cycles	175
Figure 5.2 — The effect of the movement of a trailing cyclical axis moving through time	176
Figure 5.3 — The Fibonacci grid forms when the trailing axis moves through a cycle . .	176
Figure 5.4 — The predictive qualities of the cyclical parabolic shapes when they are extruded into the future	177
Figure 5.5 — Weekly chart of the 221-week cycle and other cycles in the chord of cycles, 1966–70	182
Figure 5.6 — Weekly chart of the 221-week cycle and other cycles in the chord of cycles, 1953–57	184
Figure 5.7 — The basis of market price cycles—input vs. outgo—and the resultant TORQUE values in the trough and rebound of the cycles, 1970	188
Figure 5.8 — The relationship of earnings and the Dow industrial average—on a 15-times P/E Basis	194

Figure 5.9	— Weekly volume in two disparate 4¼-year cycles, expressed as a percentage of a five-year average volume figure	196
Figure 5.10	— The DJI expressed as a percentage of its own 52-week moving average, and whole volume expressed in the same manner	198
Figure 6.1	— The major market averages in the period from 1949 to 1972	210
Figure 6.2	— The commonality principle—four diverse stocks all tend to rise and fall with the long cycles	212
Figure 6.3	— The divergency principle—the same four stocks followed differing paths in the 1966–70 swing of the 4¼-year cycle	213
Figure 6.4	— The reaction of Control Data to the three long cycles, 1966–71	221
Figure 6.5	— The reaction of Natomas to the three long cycles, 1966–71	223
Figure 6.6	— The response of an industrial stock, General Motors, to the three long cycles, 1966–71	226
Figure 6.7	— The response of a rail stock, Southern Pacific, to the three long cycles, 1966–71	229
Figure 6.8	— The response of a utility stock, American Electric Power, to the three long cycles, 1966–71	230
Figure 6.9	— The response of General Motors to short cycle pull, 1969–71	232
Figure 6.10	— The response of Natomas to short-cycle pull, 1969–71	234
Figure 6.11	— The 12-year picture of Boeing’s response to the cycles	237
Figure 6.12	— Boeing’s response to all six cycles in the 1968–70 downswing of the market	238
Figure 6.13	— The 12-year picture of AMP, Inc.’s response to the cycles	240
Figure 6.14	— AMP’s response to all six cycles in the 1970–72 upswing of the market . .	241

TABLES

Table 1.1	— The harmonic relationships of the piano keyboard	33
Table 2.1	— Cycle response to the tangential ratio of opposing forces	93
Table 3.1	— The harmonic sine values in five cycles of differing harmonic lengths	108
Table 4.1	— Construction of 5- and 25-day moving totals of advances and declines, buying and selling volume	140
Table 4.2	— Construction of trends, whole volume total and cyclical strength vectors . .	141
Table 6.1	— The percentage swings of 10 DJI stocks in two 4¼-year cycles, 1961–72 . .	217
Table 6.2	— The percentage swings of 10 selected stocks on two upswings of the 78-week cycle in 1970–71 and in 1971–72	219



Contents



abcBourse.ir



@abcBourse_ir

مرجع آموزش بورس



باز نشر:

How You Can Profit from a Knowledge of Stock Market Cycles 7

1. THE PRICE CYCLES IN THE MARKET 25

I — The Genesis of Cycles (25)

Price cycles derive from the tick-rhythm of opposed forces 26

Cyclical impulse waves follow a tick-rhythm breakout 26

Cyclical recoil movements follow exhaustion of an impulse force 27

Interim movements mark the shift from dominance of a cyclical force . 28

Intra-day cyclical movements in individual stocks 29

Simultaneous individual moves create market cycles 29

II — The Harmonic Nature of Cycles (32)

The market's cyclical system is built of harmonic-length cycles 32

Longer rhythms are harmonic combinations of shorter rhythms 34

How cycles combine 37

How to synthesize five cycles into one market pattern 38

Why we need to understand the cyclical system 41

Cycles promise to bridge the gap to the future 42

The four parts of the cyclical principle 42

How market cycles adjust to discordant situations 43

III — A Synthesis Reveals the Market's Cyclical Nature (44)

How cycles performed in the discordant period prior to 1932 44

How cycles performed in the 1932–66 periods of the 17-year cycle . . . 45

The 17-year cycle divides business history into logical epochs 49

How longer cycles break down into shorter lengths 50

How the 4.25-year cycle of 1928–32 broke down into 17-month lengths 53

How the five-cycle synthesis matches weakness in the DJI 53

<i>The 8.5-year cycle is a double 4.25-year cycle</i>	55
<i>How to position the five-cycle synthesis correctly</i>	57
<i>Cycles establish the timing for future probable events</i>	59
2. THE FORCES AND FRAMEWORK OF THE CYCLICAL STRUCTURE ...	61
I — The Nature of the Volume Forces (61)	
<i>Stock flows from seller to buyer</i>	62
<i>The flow of volume measures buying desire</i>	63
<i>How the cyclical field is formed</i>	63
<i>Why people will pay high prices for stock</i>	64
<i>Why the closest pricebands in the field are the strongest</i>	67
<i>Volume flow determines amplitude and length of cyclical swings</i>	68
<i>In a bull market, the seller is more important than the buyer</i>	69
<i>How and why support and resistance forcebands form in the cyclical field</i>	71
<i>Support and resistance bands and triangles are really volume accumulations at harmonic levels</i>	72
<i>How volume has acted from the beginning of the DJI</i>	73
<i>How moving volume totals reveal long and short cycles</i>	78
<i>Volume plays on the market's harmonic cyclical structure</i>	79
II — The Invisible Mechanism of Cycles (82)	
<i>A cycle moves because of a thrust against its own circumference</i>	83
<i>The characteristics and properties of the Fibonacci series</i>	84
<i>The trigonometry of a square and a rectangle</i>	85
<i>The Fibonacci result from movement of the axis of a circle</i>	86
<i>The Fibonacci ratio is the sum of a square, a thrust and the phi (ϕ) additive</i>	87
<i>The Fibonacci (ϕ) additive is a portable value</i>	88
<i>The mechanics of a thrust and a recoil</i>	90
<i>The Fibonacci values control the growth of a cycle</i>	92
<i>The Golden Section and the Great Pyramid of Egypt</i>	94
3. HOW VOLUME POWERS THE CYCLE MECHANISM	97
I — Volume Alters Basic Cyclical Shapes (97)	
<i>The effect of the quantity of volume on a cycle</i>	99



<i>When buying volume expands, selling volume contracts</i>	100
<i>Prices only indicate subsurface conditions</i>	101
<i>How one force can increase and also remain equal to its opposite</i>	102
<i>How epicycles “crack the whip” at market tops</i>	103

II — Vectors in the Cyclical Field Are Controlled by Volume (106)

<i>Volume determines the angle of a cyclical vector</i>	106
<i>Vectors carry the thrust of small cycles to big cycles</i>	107
<i>Big cycles build because their “receivers” are a half-phase out of “sync”</i>	109
<i>Vectors also measure the condition of the market</i>	110

III — Cycles and the Random Walk, or, the Effect of Randoms and Seasonals on Cycles (111)

<i>Cyclical analysis can assimilate technical, fundamental and risk-factor analysis</i>	111
<i>How the cyclical field contains and tames random events</i>	113
<i>The elasticity of volume quantity contains the randoms</i>	114
<i>The seasonal pattern in average monthly volume</i>	117
<i>Why market crashes hit bottom in July and October</i>	118
<i>The reason why the “summer rally” has disappeared</i>	119
<i>Why the sixth month is the toughest in the tax-holding period</i>	121

4. TORQUE ANALYSIS OF STOCK MARKET CYCLES 123

I — The Basis for TORQUE Analysis Is That Price Is a Liar (123)

<i>TORQUE analysis shows cycles as the yield from underlying balances</i> .	124
<i>The formula for TORQUE analysis of cyclical strength</i>	125
<i>TORQUE analysis of cycles measures underlying forces, not prices</i> . .	125
<i>Two cycle radii do not always equal a cycle diameter</i>	126
<i>Opposed forces meet head-on but the effect is at a right angle</i>	127

II — The Problems of Finding the Basis of Cyclical Forces (129)

<i>How to understand price movement contradictions</i>	130
<i>Why it is important to separate buying and selling volume</i>	131
<i>How to break volume into buying and selling volume</i>	132
<i>OXY illustrates the relationships of price and volume</i>	133
<i>An example of breaking individual stock volume into two totals</i>	135
<i>How advance-decline figures improve the visibility of price moves</i> . . .	136



III — How to Set Up the Statistics for TORQUE Analysis (137)

<i>Why moving totals should equal a cycle radius</i>	138
<i>The link relationship between numbers in a time series</i>	139
<i>How to compute the TORQUE factors of cycle forces</i>	143
<i>Why price divided by volume equals radius times force</i>	144
<i>Adjusting our cycles to practical lengths</i>	144
<i>The problem of lag in moving totals</i>	145
<i>The reason we use end-formed moving totals</i>	145
<i>What a chart shows us about lag in moving advances totals</i>	147
<i>The filtering action inherent in moving totals</i>	148

IV — What the Charted TORQUE Statistics Reveal (150)

<i>The advances totals correspond closely to the Dow average</i>	150
<i>Volume totals remain closely balanced, except in large, fast down-swings</i>	152
<i>Buying causes stocks to advance; increased prices cause selling</i>	153
<i>The price-volume relationship is not a fixed ratio</i>	154
<i>The DJI velocity index defines the price-volume relationship</i>	156
<i>Cycles derive from the balance of price-volume relationships</i>	157

V — How Cycles Are Revealed by the Price-Volume Relationship (158)

<i>How the five cycles defined the 1970 trough</i>	159
<i>How the chord of cycles acted in the 1966–70 swing of the 221-week cycle</i>	162
<i>The movements of the small cycles vs. the large cycles</i>	168

5. THE ART OF FORECASTING WITH MARKET CYCLES 171**I — The Rudiments of Cycle Forecasting (172)**

<i>Cycle forecasting's seven basic assumptions</i>	173
<i>Price cycles have two axes, and, hence, follow a parabolic path</i>	174
<i>The time progression of the trailing axis causes a Fibonacci grid to form</i>	175
<i>Each mature cycle is a closed system of influence</i>	177
<i>Why price cycles spear down at cyclical troughs</i>	178
<i>The image of a new cycle derives from the peak of the old one</i>	179

II — The Technique of Cycle Forecasting (180)

<i>How to establish the limits of cyclical swing</i>	181
<i>How cycles synchronize their clocks at cyclical troughs</i>	185



<i>How the TORQUE formula overcomes lag in moving advances totals</i>	186
<i>Forecasting the future by extrusion of moving total values</i>	189
<i>By extrusion, we match the heartbeats of today's and yesterday's markets</i>	190

III — The Effect of Volume on Cycle Forecasting (191)

<i>The influence of economics on market cycles</i>	192
<i>Volume is cyclical, psychological and seasonal</i>	193
<i>The seasonal pattern in volume figures</i>	195
<i>The cyclical pattern in volume figures</i>	196
<i>The seasonal-cyclical pattern of volume in the 1966–70 market</i>	197

6. HOW TO PROFIT FROM STOCK MARKET CYCLES 201

I — Cycles Tell Us When Stocks Are Cheap, When They Are High (202)

<i>Investing should be a business proposition</i>	203
<i>Markets of the future are likely to be cyclical markets</i>	204
<i>The effect of cycles in a trendless market</i>	205
<i>The teamwork between cycles and fundamentals</i>	206
<i>Swing with long-cycle trends because you can't fight them</i>	207
<i>Commonality—The tendency of stocks to swing together</i>	208
<i>Convergence/divergence at work in major market averages</i>	209
<i>Individual issues indicate that cyclical pull is always present</i>	211
<i>Cycle response gives good clues to a stock's probabilities</i>	214

II — The Dynamic Potential of Stock Market Cycles (215)

<i>Large cycles have narrow swings but broad effects on stocks</i>	216
<i>The 78-week cycle also has lots of cyclical "punch"</i>	218
<i>The 1966–70 swing of the long cycles and the performance of Control Data</i>	220
<i>The 1966–70 swing of the long cycles and the performance of Natomas</i>	222

III — The Fidelity of Cycles Defined by TORQUE Analysis (224)

<i>The response of an industrial stock, General Motors, to long-cycle pull</i>	225
<i>The response of a rail stock, Southern Pacific, to long-cycle pull</i>	227
<i>The response of a utility stock, American Electric Power, to the long cycles</i>	227
<i>The response of General Motors to short-cycle pull</i>	228
<i>The response of Natomas to short cycles</i>	233



IV — Cycles Provide Perspective for Market Decisions (235)*The effect of cycles on a stock with declining fundamentals* 235*The effect of cycles on a stock with good fundamentals* 239*The relationship of cycles and the Elliott Wave Principle* 242**Index** 245

Investing for Profit with TORQUE Analysis of Stock Market Cycles



abcBourse.ir



@abcBourse_ir

مرجع آموزش بورس



باز نشر:

The Price Cycles in the Market 1

There is a history in all men's lives,
Figuring the nature of the times
deceased,
The which observ'd, a man may
prophesy
With a near aim, of the main
chance of things
As yet not come to life, which in
their seeds
And weak beginnings lie
intreasured.

—Shakespeare

I—The Genesis of Cycles

Stock prices move in direct response to only two influences—stock market cycles and the economic outlook—and only indirectly in response to such things as fashion, fundamentals and fiction.

This is fortunate (1) because economic trends are usually long-range movements and, in any event, are now so thoroughly studied and well-publicized that with a modicum of effort a man can become a passable amateur economist, and (2) because cycles in the market beat and repeat with such remarkable regularity that from a study of cycle history . . . “a man may prophesy with a near aim, of the main chance of things as yet not come to life . . .”

Cycles in the stock market arise from the rhythmic vibrations of the price of individual stocks as they respond to the daily forces of buying and selling and to the quantity of volume which is generated by these forces. These initial vibrations are recorded daily in your newspaper as the high and low prices reached by each stock, together with the volume generated.

Since these vibrations of price gather force as they accumulate in harmonic waves, the resulting waves of buying and selling become longer and stronger, until, in combination with trend, they dominate market movements. The wave buildup, which comes in surges, derives from anticipation. As more and more stocks rise in price (or a single stock rises higher), the urge-to-buy becomes stronger in a would-be buyer as anticipation of profits grows. As more and more stocks fall in price, the urge-to-sell becomes stronger in a would-be seller, as anticipation of losses grows. As a movement continues, anticipation accelerates with prices and is slowly replaced by hope (or fear). Since



hope is boundless, so is the buildup of cyclical forces into longer and longer cycles.

Short cycles in the market reflect the day-to-day balance of buying and selling, and the longer cycles reflect a longer balance and become, in effect, a trend around which shorter price cycles tend to oscillate. The real trend of the market, however, is set by the current economic outlook.

Since the economic climate affects the earnings of most, if not all, companies, it is only natural that the price of a company's stock is strongly affected by the prospects for the economy. Since the "market" is measured by an average of individual stocks, it is only natural that market-average indexes are affected by the same prospects. The current trend of the nation's business thus becomes the current trend of the market, and the slant of the trend, whether upward, downward or level, affects the shape of the market rhythms.

Price cycles derive from the tick-rhythm of opposed forces

Price-cycle movements in the market derive from the rhythmic action of two equal but opposed forces as they seek equilibrium. The forces are intangibles: They are (1) the desire to buy and (2) the desire to sell. They remain intangible at all times because, like gasoline in an automobile tank, only a small portion of the total reaches the engine and is expressed in market transactions. A measure of their relative strengths can be obtained, however, when a decision has crystallized a desire, at which time desire becomes buying volume or selling volume, depending on the direction of the price movement. Since the intangible forces of buying and selling are seldom, in practice, of equal power—if they were, all transactions would be executed at the same price, like canned goods in a grocery—the two forces constantly alternate in dominance.

It is important to remember that the forces are equal in magnitude but opposite in sense or direction, and that one force can become dominant only at the expense of the other, since, at any given moment, there is a finite quantity of would-be buyers and would-be sellers who are close to a decision. The total amount of the two groups changes with volume fluctuations, but at any one time there is always a finite quantity. Even a small expansion of one force thus must result in compression of the other, and, to regain equilibrium, the second force must react oppositely to the first force.

When this occurs, as it constantly does in the market, the confined forces oscillate narrowly across a balance of power, and prices in the market alternate upward and downward in a narrow range, generally with small volume—since only a few buyers and sellers find the price attractive enough to reach a decision and because, when price is alternating narrowly, there is little apparent indication of which direction prices will follow.

This limited alternation of force between the desires is the basic rhythm of the market—a rhythm which we have labelled tick-rhythm. It resembles an idling engine, operating on low volume and with minor force.

Cyclical impulse waves follow a tick-rhythm breakout

When prices are idling in tick-rhythm, it can be expected that shortly one force or the other will become fully dominant. When the breakout comes, the movement of



price will crystallize nearby decisions—either by impulse moves of near-would-be buyers or sellers or by predetermined limit orders—and prices will move above or below the tick-rhythm range in a string of transactions, called an impulse wave, in which one force is almost completely dominant. When demand is dominant, prices of a stock will move upward in a series of transactions interspersed by only occasional downticks. When supply is dominant, prices will move downward in a series interspersed by only occasional upticks.

If the price movement is upward, the movement intensifies desire-to-buy and forces a decision on a would-be buyer since price is moving and no longer static or confined to a narrow range. A decision to buy causes additional decisions in other would-be buyers, and theirs, in turn, cause others, so that the upward movement continues in a chain reaction. Another factor which helps to lengthen the impulse waves is that, as prices move upward, the supply of stock being offered at each uptick diminishes at the same time that demand is increasing.

Would-be buyers can only buy stock from pessimistic owners who, as the price rises, become less pessimistic and withdraw their sell orders, since everyone would like a little higher price for his stock. The would-be buyer thus must reach for his stock at higher and higher—and less and less desirable—prices or go without. When prices move downward, the supply of stock being offered at each downtick increases at the same time that demand is diminishing. Would-be sellers can only sell stock to optimistic buyers and, as prices decline, buyers turn less optimistic and more opportunistic and withdraw their buy orders, since no one is adverse to buying lower. The would-be seller thus must sell at lower and lower—and less and less desirable—prices or hold his stock.

This carrot-and-stick system of prices causes price to move rapidly in a string of transactions after the first breakout from the tick-rhythm range. So long as demand for a stock continues dominant in the face of ever decreasing supply, the upward movement will continue. So long as supply of a stock continues dominant in the face of ever decreasing demand, the downward movement will continue.

Cyclical recoil movements follow exhaustion of an impulse force

Upward (or downward) impulse movements will continue from a breakout of the tick-rhythm confines to a point where the price of a stock makes it no longer desirable to would-be buyers (or sellers). When this point is reached, the upward impulse force is exhausted and a recoil movement from the impulse wave begins. Typically, this is accompanied by a gradual decrease in the volume of trading.

An upward impulse movement will generally end in a short series of topping-out trades which resembles but is shorter than the tick-rhythm range at the bottom of a movement. The top of the range will form as the highest price is repeated, and a bottom will form at the low end of the short vibrations of tick-rhythm prices. When it is established by a succession of these oscillating trades that price cannot effectively increase above the top of the range, a recoil will start. Prices will drop rapidly after the bottom of the range breaks, just as, in an impulse movement, prices move rapidly from the top of a range. Selling forces will remain dominant until price reaches a point at which selling no longer is attractive to would-be sellers.



The amount of recoil from an upward impulse movement is a vital measurement, since it is largely determined by the amount of selling which accompanies the downturn. If the movement is short, as it usually is in an upward trend, the probability is that buying will soon re-establish itself as the dominant force and prices will continue upward from the recoil. If the movement is deep, however, it is indicative of one of two things: either the trend of prices has turned downward or (2) there has been no basic trend during the upward movement.

When an economic—or long cyclical—trend is upward, the force of this trend generally will keep prices from recoiling excessively from the upward cyclical impulse movement. For instance, if the power of an upward cycle movement increased from zero to two, as the impulse wave developed, and trend had an upward power of two, it would be probable that the recoil movement would stop in the neighborhood of the two-power value of trend. If trend is flat, or in the process of turning from upward to downward, trend would have no value and the cycle would recoil to the zero from which it originated. The recoil movement of a cycle, as it adjusts to the change from an upward pressure to a downward pressure, is as important as, and on occasion more important than, the impulse movement, since, in effect, it indicates the power and type of the underlying trend.

Interim movements mark the shift from dominance of a cyclical force

Many people are of the opinion that market cycles consist of only two movements—upward and downward—and are thus very disappointed when a cycle refuses immediately to respond to the timing *they have established* for the cycle.

Part of the disappointment arises from a failure to realize that cycle lengths are variable and part from a failure to understand that cycles, no matter what they look like in stock charts, are curves and not zig-zags. In any oscillating curve, there are four basic parts: (1) the upward movement, which we have described as impulse waves; (2) the downward movement, which we call recoils; (3) the troughing and (4) the peaking portions of the curve, where movement slows as one cyclical force is gradually overcome and the direction of movement begins to reverse. These latter periods we have labelled as interim periods.

The interim periods are usually the tick-rhythm periods which we described earlier. They are periods of adjustment when the forces of selling and buying are in close balance, regardless of the quantity of the forces. At these times, cycles are like an idling—or even a racing—engine. The gears are shifting, but until someone lets the clutch out, nothing much is going to happen.

Interim movements are most visible following a recoil wave, when the force of the impulse wave has been balanced by the force of the recoil and the balance of power between the two has reverted to near zero. If an interim period happens at the end of an impulse wave, it can occur only if trend is sufficiently strong to support prices until the cyclical forces have adjusted at the higher level. In this case, it is likely that the interim period will take the shape of a triangular formation of prices—a formation in which the forces alternate in power in shorter and shorter swings, or, in an expanding triangle, in longer and longer swings.



Intra-day cyclical movements in individual stocks

We have been talking, of course, about basic cyclical movements—particularly as they appear in individual stocks. The fact is, however, that these basic movements appear throughout the market's cyclical system as well. The reason is that, just as a market average is made up of the average movements of the included stocks, the market's cyclical system is composed of many cycles working in harmonic combination. Study of a cycle in a single stock thus leads to market analysis.

For instance, Fig. 1.1 is a chart of a single day's transactions in Occidental Petroleum on November 20, 1967. For background, this was the Monday following the Saturday devaluation of the British pound from \$2.80 to \$2.40—an event which caused a quick reaction on Monday morning and dropped the Dow from the Friday close of 862.11 to an opening figure of 843.22—a drop of 18.89 points—and resulted in a decline for the day of 4.33 points in the DJI. The following day, the Dow rallied 13.17 points, and the movement, which followed the Monday reversal day, carried the Dow to a high of 921.87 the following January.

OXY opened trading late in the day—shortly before noon—at a price of 91 which was down $3\frac{7}{8}$ points from the Friday close on an accumulation of overnight and early morning orders. From this low, an impulse wave carried the stock upward for 107 transactions until shortly after 12:30 p.m. A total of six trades at the same figure established that the price of $93\frac{1}{2}$ was the top of the impulse wave. A short, topping tick-rhythm movement ensued, but when price fell through the bottom of the range on the 123rd trade, the recoil movement carried prices down until OXY hit a bottom for the day at 88 on the 262nd trade, soon after 1 p.m.

An upward rebound established that 88 was the bottom of the recoil movement, and the third cyclical movement—the interim period—set in. The stock oscillated in tick-rhythm until the 344th trade broke above the confined range and a small rally ensued. From this rally, the stock oscillated upward and downward in small rallies and declines until a second impulse wave started prices moving upward from the low of $89\frac{1}{8}$ on the 656th trade shortly before 2:30. The small rallies which intervened between the end of the tick-rhythm movement and the beginning of the impulse wave were, in reality, a continuation of the interim period, rather than being genuine impulse-and-recoil waves, since OXY was extremely active that day, trading 287,600 shares.

On the same day, another big-priced stock—Fairchild Camera, illustrated in Fig. 1.2—traded heavily and went through movements similar to those of OXY. Fairchild opened earlier than OXY and moved directly upward from the opening price of $90\frac{1}{2}$ (down from Friday's close of $96\frac{1}{2}$) to a peak of $95\frac{5}{8}$ on the 56th trade, and then went into a tick-rhythm topping movement until the 99th trade shortly before 11:30. From here the course of prices was generally downward until 1:30, when an interim movement set in, while FCI awaited the beginning of the next impulse wave, which came almost at 2:30.

Simultaneous individual moves create market cycles

During the course of a day's trading, nearly all individual stocks develop a series of price swings similar to those in OXY and FCI, except with generally smaller ampli-

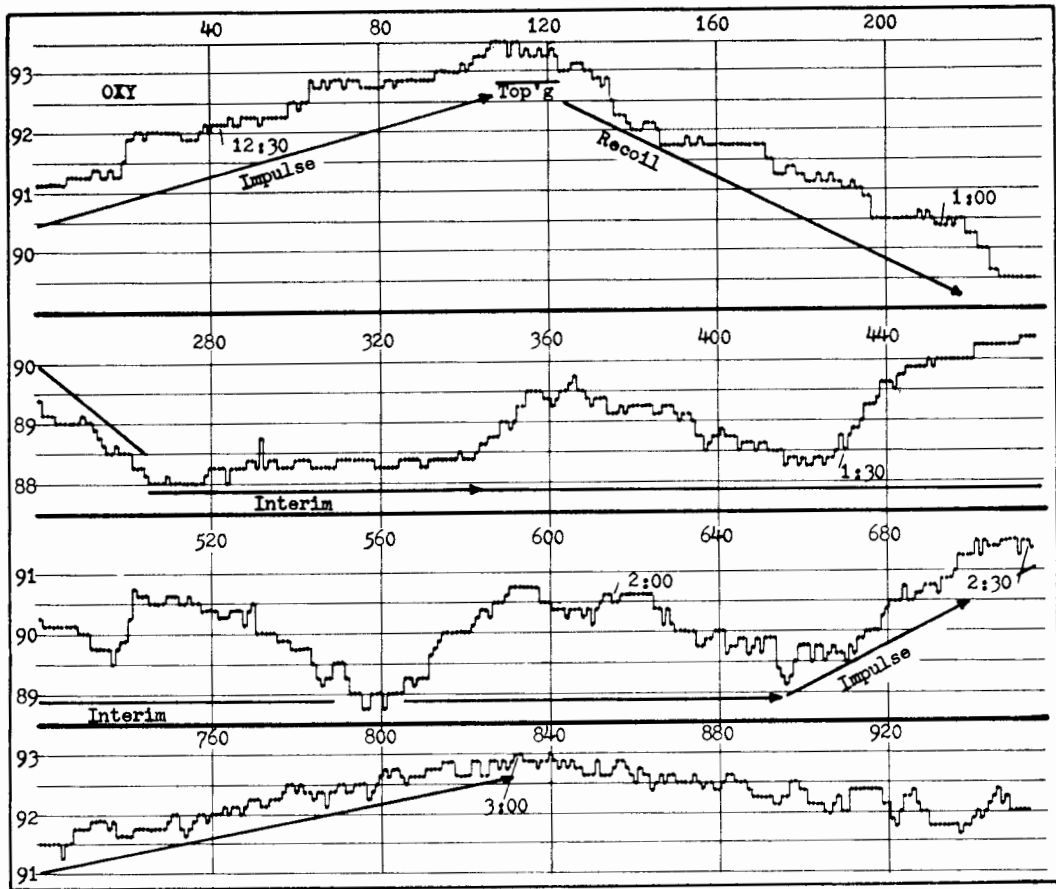

Fig. 1.1—Transaction-by-transaction chart of the trading in Occidental Petroleum on Monday, November 20, 1967.

tude. Some of the swings will be spurious movements, such as those which occurred in OXY's interim period, but in the collection there will be rhythms which are each stock's response to a fundamental market stimulus. These fundamental responses are the genesis of market rhythms because the swings of individual stocks at such a time will start almost simultaneously.

For instance, in Figs. 1.1 and 1.2, we can see that FCI was in an impulse wave from the opening of trading to about 11:00, and then prices recoiled until 1:00. OXY opened trading just before noon on that day, and, after the initial rally, also recoiled until shortly after 1:00. The interim movements of both stocks coincided, despite the big volume of trading in OXY and the subsequent small rallies, so that both stocks were in a position to rally with the beginning of the second impulse wave of the day which began about 2:30. That is, in both stocks there occurred the three phases of a cyclical rhythm—the impulse, the recoil and the interim sideslipping. Other stocks also felt the



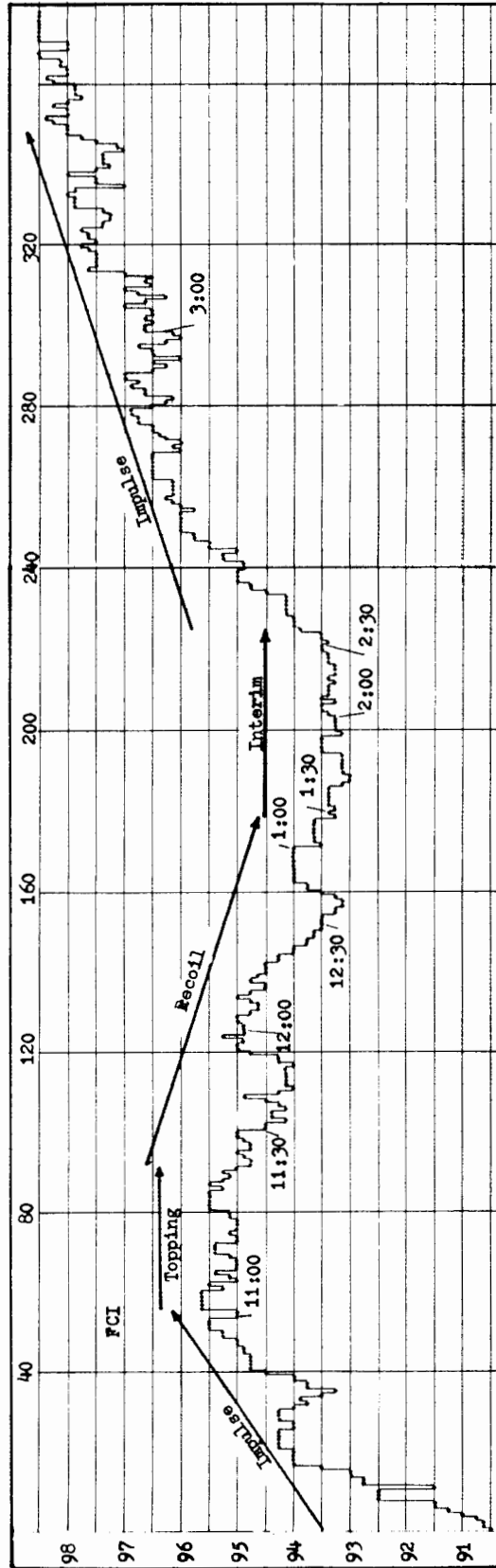

Fig. 1.2—Transaction-by-transaction chart of the trading in Fairchild Camera on Monday, November 20, 1967.

impact of these impulses, with larger-priced stocks reacting widely to the impulse and recoil and the smaller-priced stocks reacting in a narrower range.

This particular Monday was an unusual day with a major news event occurring between the Friday closing and the Monday opening. In conjunction with the 18.89-point reaction of the 30 Dow industrials, the whole market was affected. The count of the 1482 stocks which traded on the New York Stock Exchange that day showed that 1172 stocks declined and only 193 advanced from their Friday closing price. The market rallied from the opening, so that at the close most stocks had largely recovered from their low opening prices.

This rally carried through the next day, and the advance-decline count for Tuesday reversed the Monday figures so that 1049 stocks advanced and only 265 declined. From the movement of our sample stocks and from the action of the advance-decline figures, we can interpret that the prices of about $\frac{4}{5}$ ths of all active stocks moved almost simultaneously during the two days. That is, 1172 went down on Monday and 1049 went up on Tuesday. The reactions which we saw in OXY and FCI thus did not affect them alone, but also were expressions of the reactions of about 80% of the whole NYSE list.

II—The Harmonic Nature of Cycles

Cycles “fit” together. Thus their influence principally results from the combination of strengths and weaknesses of individual cycles working as a team. When all the cycles are pulling up together, prices in the market rise rapidly since all influences are toward higher prices. When some of the cycles are pulling in different directions, stocks tend to lose their unanimity of movement and prices go in all three directions—up, down and sideways—at once. The “fit” which makes cycles of varying lengths “cooperate” is similar to the harmonics which are essential to music and which allow a piano to have several octaves, or versions, within a single keyboard.

The market’s cyclical system is built of harmonic-length cycles

The market cycle which we saw begin in the movements of OXY and FCI was a part of a much larger system of cycles which operates in the market. The system is formed by the simultaneous vibrations of a combination of cycles whose lengths are harmonic numbers of the originating vibrations. The market’s cyclical system thus bears a strong resemblance to the musical chord system.

The musical system derives from a 6th-century BC discovery attributed to Pythagoras, that a taut string which produces a C note will sound a C note one octave lower if the string’s length is doubled and a C note one octave higher if the length is halved. In between these lengths, the other notes in the octave will sound when the strings are lengthened or shortened in (mostly) fifteenths of the original length. For instance, B will sound at $\frac{16}{15}$ ths of the original length, A at $\frac{18}{15}$ ths, G at $\frac{20}{15}$ ths, F at $\frac{22.5}{15}$ ths, E at $\frac{24}{15}$ ths, D at $\frac{26.66}{15}$ ths and the lower C at $\frac{30}{15}$ ths.

Since harmonic lengths are those whose reciprocals are in arithmetical progression, if we divide the denominator of the fractions (15) by the numerator, we arrive at the reciprocals:



Table 1.1—The harmonic relationships of the piano keyboard.

	(1)	(2)	(3)	(4)	(5)
	<i>Fraction</i>	<i>Recip- rocal</i>	<i>16th Prog.</i>	<i>G as 1.0000</i>	<i>Multiple of .1666</i>
C =	120/15	0.1250	0.1250	0.1666	× 1.0
C =	60/15	0.2500	0.2500	0.3333	× 2.0
C =	30/15	0.5000	0.5000	0.6666	× 4.0
D =	26.66/15	0.5625	0.5625	0.7500	× 4.5
E =	24/15	0.6250	0.6250	0.8333	× 5.0
F =	22.5/15	0.6666		0.8888	× 5.3
			0.6875	0.9166	× 5.5
G =	20/15	0.7500	0.7500	1.0000	× 6.0
			0.8125	1.0833	× 6.5
A =	18/15	0.8333		1.1111	× 6.7
			0.8750	1.1666	× 7.0
B =	16/15	0.9375	0.9375	1.2500	× 7.5
C =	15/15	1.0000	1.0000	1.3333	× 8.0
C =	7.5/15	2.0000	2.0000	2.6666	× 16.0
C =	3.75/15	4.0000	4.0000	5.3333	× 32.0

The progression of notes, while not perfect because of the F and A note spacings from G, is a true arithmetic progression. Because it is also a harmonic progression, it works in both directions, so that, if we consider G as the center of the center octave (as in column 4 of the table), the progression is both fractional and multiple. That is, the reciprocals of the notes below G are fractions of G in length and those above G are multiples of G in length. If we start at the lowest C, in column 5 at the top of the table, we find that each note is a multiple of the first note and also that there is a geometric, or multiplied, progression between octaves.

The similarity of music and cycles could theoretically be carried to infinity except that music is limited to the audible range. With cycles, while there is no such mechanical cutoff, there is another caused by the availability of data—so, while we can isolate and describe accurate average lengths for the smallest (high-frequency) cycles, or those whose oscillations in time are so rapid that sufficient repetitions are available, we cannot describe the swings of huge (low-frequency) cycles whose length progresses geometrically, since a cycle can't be identified unless it has been repeated with regularity enough times to be credible.

Since it is apparent from the table that we could find many harmonic cycles in any reasonable spectrum, it is also apparent that we can find cycles at any of several locations around certain central positions (note the F and A "mis-spacing"). It is necessary, therefore, to study and isolate each of a group of cycles and determine those which produce the greatest effect. This we have done, and as a consequence we have arbitrarily assigned five of the most important cycles to a cyclical "chord" with which we will work, since

it appears that these five cycles will answer most of the “what happened?” and “why?” questions we will face in the market. These five cycles are relatively short in length because the DJI was only started in 1897, which is not sufficient time for many repetitions of a long cycle, which is also why we cannot confirm the presence of a 34-year cycle.

The cycles we shall use are illustrated in Fig. 1.3. Their lengths are two weeks or 10 trading days (not illustrated), 10 weeks, 25 weeks, 75 weeks and 225 weeks.* The fractions and reciprocals are:

$$\begin{aligned} 25/10 &= 0.4000 \\ &\quad (0.2000) \\ 75/10 &= 0.1333 \\ &\quad (0.0666) \\ 225/10 &= 0.04444 \end{aligned}$$

The cycles thus are harmonic lengths of the 10-week cycle, and, also, of the two-week cycle. We also can see a hint that there might be rhythms between these rhythms, since the reciprocal of a 50-week rhythm would be 0.2000 and a 150-week rhythm 0.0666.

Longer rhythms are harmonic combinations of shorter rhythms

The basic rhythm of the market—or at least the first one which is readily measurable—is the 10-day rhythm; a second basic is the 10-week or 50-day rhythm and the third is the 25-week rhythm. The rhythms play the same role in the cyclical system as the basic notes in a musical chord system. For instance, the basic musical chord of C is composed of the C-E-G notes played simultaneously, and to this combination can be added other whole notes or half-notes which are harmonious—or the C-E-G chord can be played without additional notes, or, simply, the C note can be played alone.

In the market system, however, the short cycles are so affected by the long cycles—and the long cycles by the short cycles—that a single cycle cannot be taken out of context, since the relationships it has with other cycles can affect its amplitude so that it becomes, at times, unrecognizable. For instance, while the 25-week rhythm is one of the basic rhythms of the market, it cannot be readily seen in a chart half of the time. Unlike the two-week and the 10-week rhythms which have a regular beat, the 25-week rhythm often “misses” every other beat because its upward and downward influences are diluted by the overriding effects of adjacent rhythms. The result is that the first effective, regular cycle of the market after the 10-week rhythm becomes the 75-week rhythm, instead of the 25-week beat which we would expect.

The first effective “chord” of market rhythms, thus, ends with the 17-month or 75-week cycle and the second includes the 4.25-year or 225-week cycle. This cycle,

* When we ascribe specific lengths to cycles, we are talking approximations, since an exact average, taken over a sufficient number of swings to eliminate doubt, would almost certainly not arrive at a nice round number. For our purposes, approximations are sufficiently accurate, since the main purpose of the approximation is to provide a reasonable length for a moving total which will record a cyclical swing. In this situation, the only thing lost is cyclical amplitude or the amount of swing from peak to trough.



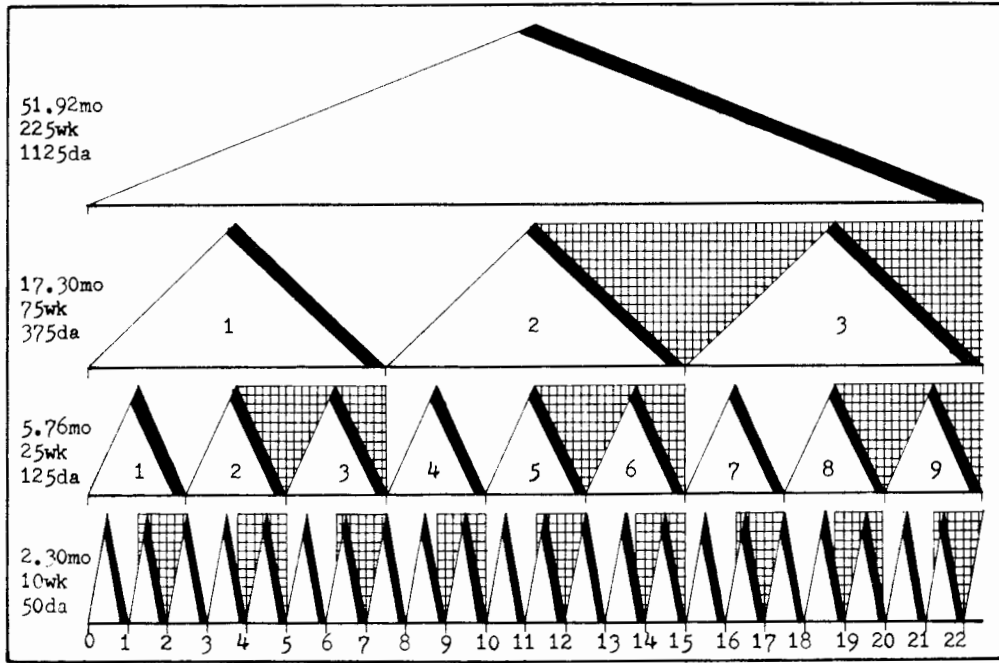

Fig. 1.3—Four of the five harmonic-length cycles of the market. In addition to those shown, a cycle of two weeks is also present in the harmonic pattern.

which is the largest really effective cycle, is composed of cycles of these lengths: 10-day, 10-week, 25-week, 75-week and 225-week. The 10-week rhythm is five times the length of the first rhythm, the 25-week rhythm is 2½ times the length of the 10-week rhythm, and the 75- and 225-week rhythms are each three times the length of the preceding rhythm. With a little multiplication, we can get hints of rhythms of 8½ years, 17 years, 34 years, etc.*

The intra-day rhythms are the really basic rhythms of the market, but the first measurable rhythm is the 10-day cycle. For instance, in Fig. 1.4 we see another transaction-by-transaction chart, this time of City Investing, on Monday, December 4, 1967—two weeks later than the OXY and FCI transaction charts. In this chart, we can see action very similar in shape to the OXY and FCI charts which we saw earlier. Here we can see that an impulse wave carried the price from the opening of 83 to a top of 90½. A series of trades at 90½, with a minor exception, established the top, and prices recoiled to 88. Selling was exhausted on the 74th trade, and a small tick-rhythm established a bottom for the recoil movement since buying and selling got back into

* Literally hundreds of cycles in a wide spectrum of economic, physical, natural and other sciences have been alleged. The Foundation for the Study of Cycles, Inc., 124 So. Highland Ave., Pittsburgh, Pa. 15206, has published catalogs of these allegations.

equilibrium. On the 92nd trade, another impulse signal was received and the movement carried to a high of 91½ before trading ended.

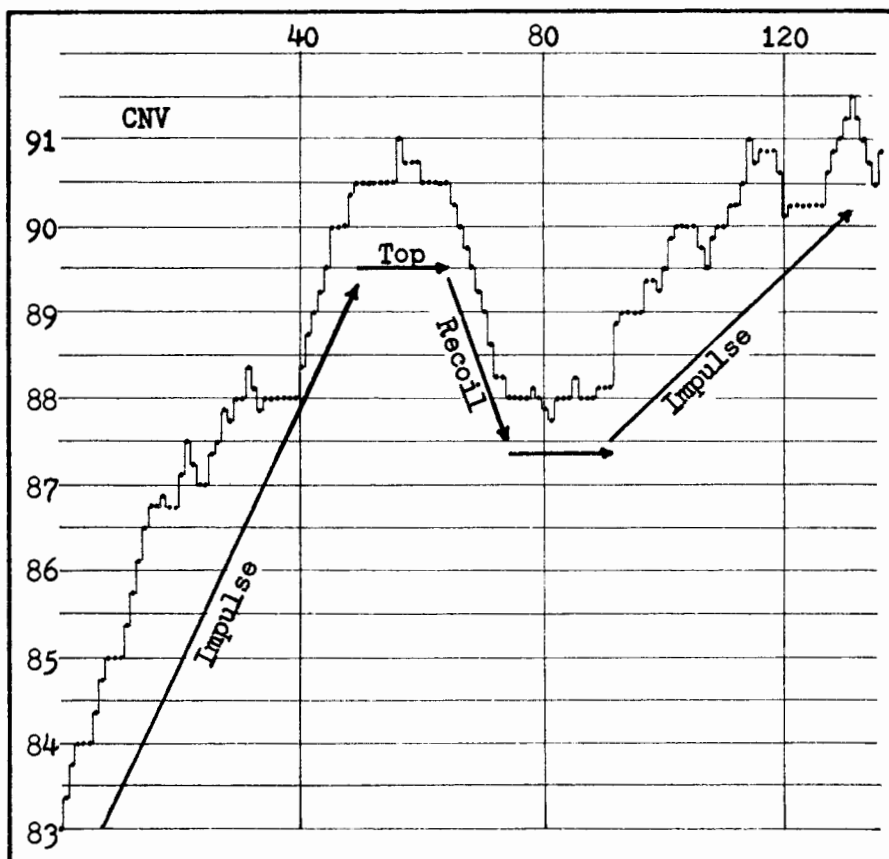

Fig. 1.4—Transaction-by-transaction chart of trading in City Investing on Monday, December 4, 1967.

In Fig. 1.5, which shows the Dow industrial average on a daily basis, we see what happened to the market during this same period. Monday, Nov. 20, was a short-cycle reversal day which ended a long cyclical downswing of the average. The cyclical impulse which started about 2:15 in OXY and just after 2:30 in FCI was a genuine force, since it was the force which launched the rally from about DJI 840 to above 900 on December 7. The rally from the November low carried upward eight days (including the holiday) to a high of about 895, and the recoil dropped the Dow to a low of about 869 two days later. December 4 saw the beginning of a new rally and established that there was a good possibility of a 10-day cycle in the market's rhythm system—since the rally in CNV was almost identical with the OXY and FCI rallies 10 trading days previously.

We can also see that the cycle in the DJI which hit a low of 839.40 on November 20 also hit a previous low on Monday, August 28, which is exactly 12 weeks previous



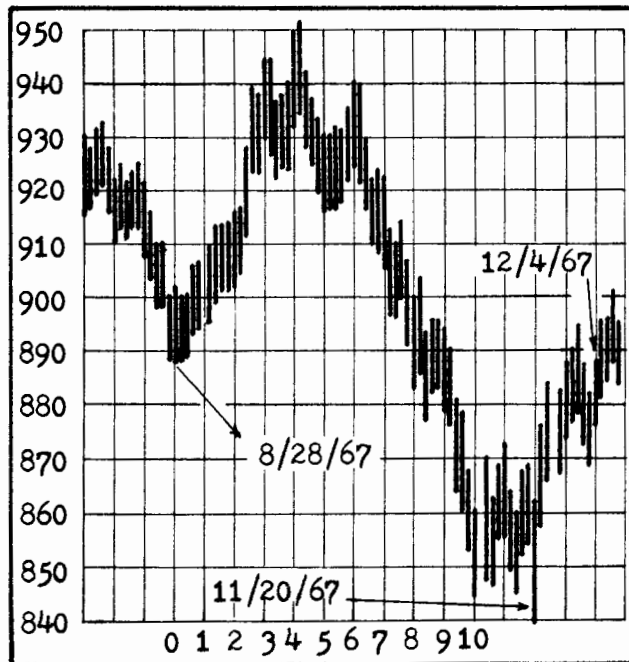

Fig. 1.5—The Dow Jones industrial average of 30 stocks in the latter part of 1967.

to the November 20 low. Here, therefore, we have a hint of the next larger cycle, since we can see that a low not quite as low as the Nov. 20 low occurred two weeks previous (on November 6) and that, in reality, the market went sideways between the two dates. Since it looks, from the illustration, like the end of the downward recoil of the cycle ended on November 6, we can assume that the cycle is really 10 weeks in length and that the two-week interval between the recoil and the next impulse was an interim period of the cycle, even though it was dominated by the two-week cycle. This, of course, raises the problem of the 10-week cycle's real length—whether to include the interim period in the measurement or whether to exclude it.

How cycles combine

From this type of eyeball spadework with other charts, we can also isolate longer cycles in the market which are significant because they are the source of recurring undulations of the market averages. Before we rush headlong into our search for cycles, however, we need to know a little more about how cycles combine into the longer rhythms and what the longer rhythms are supposed to look like.

Referring again to Fig. 1.3, which illustrates four of the five cycles which appear to be the most potent cycles of the market, we see that hidden within the rhythm of the 51-month cycle are the undulations of three other cycles plus the 10-day cycle which is not shown. Within the span of the 51-month cycle are 22½ oscillations of

the 10-week rhythm, nine oscillations of the 25-week rhythm and three oscillations of the 75-week rhythm.

Further, we can see that each larger cycle in the group throws a cloud (hatched area) over the lesser cycles when the larger cycle has reached its zenith and is moving down toward its nadir. That is, the 51-month cycle is a supporting influence from the trough to the peak, but, from its peak to its nadir, it acts as a downdrag on the action of the lesser cycles. For instance, the 51-month cycle helps the uplift of the 75-week cycle in the first two upward legs and aids in offsetting the downward phase of the 75-week cycle in this period.

After the cycle has reversed, however, it adds to the downward pull of the down legs of the 75-week cycle and depresses the upward leg of the final oscillation of the cycle. In the 25-week cycle, its upward legs are assisted in the first four-and-a-half of the nine oscillations and are depressed in all but two of the upward legs in the second half. That is, the 51-month and the 17-month cycles act as upward and downward trends during their phases. Thus they strongly influence the performance of the lesser cycles.

With two small hypothetical cycles, we illustrate in Fig. 1.6 what happens when two simple cycles are combined. First, the upward cyclical action of the long cycle acts as a trend and carries the upward legs higher on each revolution of the small cycle until the large cycle peaks at point 5. Here the trend changes and the downward legs of the small cycle are carried a little further downward on each revolution. Now, as we can see, the upward thrust of legs 1, 3 and 5 in the large cycle's ascent gets less powerful in each version. That is, the original impulse of the large cycle carried the wave upward to a value of 130 and the recoil leg backed down to 59. The next upward leg of the large cycle carried to 180 but the distance travelled in this impulse was only 121 points (from 59 to 180). The third impulse leg took the cycle to a high of 200 but this peak was only 105 points above the second recoil point at 95.

The strength of each successive wave, thus, diminishes as the cycle approaches its zenith. On the downside the reverse is true; each downward leg gains in intensity as the cycle moves downward. That is, as each rally from a downward move fails to carry above the previous rally, the urge to sell becomes stronger and stronger in the minds of near-would-be sellers and selling volume increases—just as, on the way up, the desire to buy became stronger on each rally which carried above the previous one at points 3 and 5.

How to synthesize five cycles into one market pattern

In Fig. 1.6, we illustrated a simple synthesis of two cycles. In Fig. 1.7, we illustrate how the five principal cycles of the market combine, on a weekly basis, and how the synthesis forms a pattern which is very different from the simple two-cycle combinations. This synthesis is constructed by assigning each of the five cycles an arbitrary value of 1.0000 and by spacing sine values equally between zero and 1.0000 according to the number of weeks in the length of each cycle. That is, the 10-day cycle oscillates in the first week from zero to one and in the second week from one to zero, etc. The 10-week



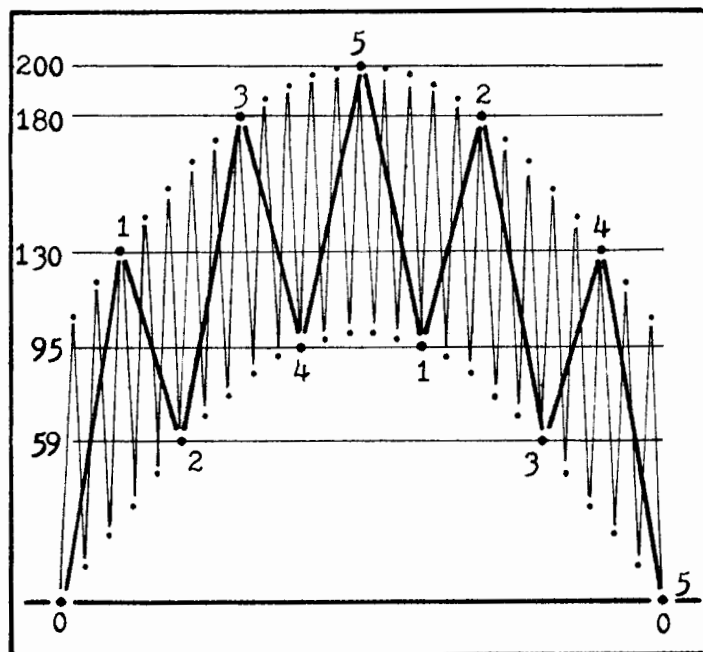

Fig. 1.6—A synthesis of two cycles.

cycle oscillates from zero to one in five steps—0.0000, 0.3090, 0.5878, 0.8090, 0.9511 and 1.0000—and from 1.0000 to zero in five more steps. The same method is used to assign values to the 25-week cycle, except that there are 12½ weeks in each half of the 25-week cycle. Since we are working with full weeks (five trading sessions) in this synthesis, the 25-week cycle never quite reaches 1.0000, so that the sine values are 0.1253, 0.2487, 0.3681, 0.4818, 0.5878, 0.6846, 0.7705, 0.8443, 0.9048, 0.9511, 0.9823 and 0.9880 and reverse. Now, from these values, we can see that the two series of sine values (the 10-week and the 25-week) are harmonic because the values of 0.5878 and 0.9511 are contained in both series. The same is also true of the larger cycle series of 75 weeks and of 225 weeks.

The same system of spacing is used for the sine values of the larger cycles, and the value of the combined cycles is determined by totalling the values (and dividing by five if you wish to reach an average). The values assigned for the first few weeks (harmonics in italics) are:

225-wk	—	0.0000	0.0140	0.0279	<i>0.0419</i>	0.0558	0.0698	<i>0.0837</i>
75-wk	—	0.0000	<i>0.0419</i>	<i>0.0837</i>	<i>0.1253</i>	0.1668	0.2079	<i>0.2487</i>
25-wk	—	0.0000	<i>0.1253</i>	<i>0.2487</i>	0.3681	0.4818	<i>0.5878</i>	0.6846
10-wk	—	0.0000	0.3090	<i>0.5878</i>	0.8090	<i>0.9511</i>	1.0000	<i>0.9511</i>
2-wk	—	0.0000	<i>1.0000</i>	0.0000	<i>1.0000</i>	0.0000	<i>1.0000</i>	0.0000
			1.4902	0.9481	2.3443	1.6555	2.8655	1.9681

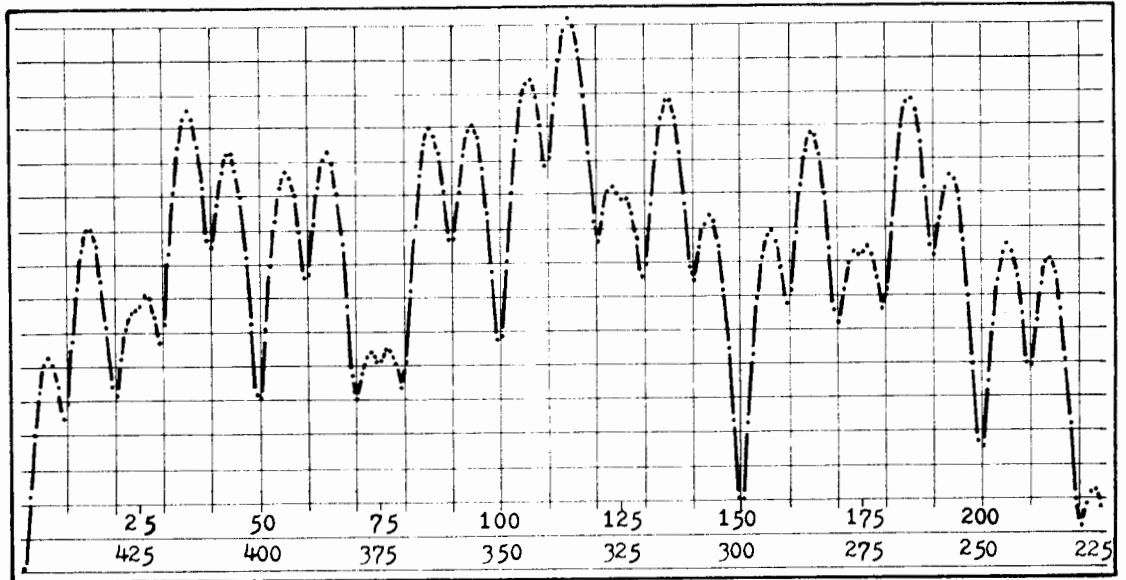

Fig. 1.7—A synthesis of five principal market cycles, combining the 10-day, 10-week, 25-week, 75-week and 225-week cycles.

Now, as we can see, the direct combination of values gives wide swings between the numbers in the total. In order to smooth these variations, we average the strength between each of two intervals. When this is done, a better picture of the synthesis is available since the new numbers become:

Average—0.0000 1.2192 1.6462 1.9999 2.2605 and 2.4168

When these average figures are plotted, as in Fig. 1.7, the synthesis follows a nice regular pattern—upward for five weeks and downward for five weeks. (Since, as we see, the first plot in a beginning synthesis is zero, the first plot is not shown at full value in the illustration.)

From the illustration of the varying strengths of each cycle at each plot, we can see how the cyclical system of the market operates. For instance, the track of the 10-week cycle is quite obvious as a series of five upward and five downward plots for two revolutions. In the third 10-week cycle, however, we can see that the upward and downward movements are suppressed. This is due to the decline and gradual buildup of the 25-week cycle as it goes to 0.0000 on the 25th occurrence. The synthesis remains on a high level, however, because on the 25th plot the 10-week cycle is at full strength. For the 25th plot, both the 10-week and the 25-week cycles are approaching zero, so that strength in this phase comes only from the two-week and 75- and 225-week cycles. A similar occurrence to the 20- to 30-week area occurs at the 70- to 80-week area and again in weeks 120–130 and 170–180, indicating the effect of the 25-week cycle.

The whole synthesis peaks between weeks 112 and 113 when the 225-week cycle



reaches a zenith. We can also see that this cycle has acted as an uptrend from the beginning, carrying the combined cycles in a gradual upward movement. From the zenith, the 225-week cycle becomes a downward trend carrying the combined cycles back to their nadir at the 225th week. Now it is interesting to see that, because of the action of the lesser cycles, the combination does not return to zero in week 225. Instead, the low is reached in the 220th week when the 10-week cycle is at zero, and this cycle, combined with the two-week cycle, keeps the figures above 1.0000 during this period. From the 225th week, the cycle reverses, so that the 250th week plot is the same as the 200th week and the 275th week plot is the same as the 175th week. As we shall see later on, the period between the 220th and the 230th weeks is the matching up of what is really a double cycle, since it is not until the 450th week (8.65 years) that the synthesis will return to a strength of zero.

We can also see from the synthesis why there aren't effective cycles of 50- and 150-week lengths. With the combination of the 25- and the 75-week cycles acting as cycles of these lengths, who needs the 50- and 150-week cycles?

Why we need to understand the cyclical system

Cycles in the market act as the major influence on the movement of stock prices. In coordination with trend (cyclical), they drive the price of a stock upward and they drive the price downward, taking the "market" of stocks-in-an-average upward and downward like leaves before a gusty wind. Some of the cycles—and some of the price movements—are short, and some, as we have seen, are long and continue to drive prices up or down, sometimes even beyond what passes for reasonable—as witness 1962–66 and 1928–32.

Despite their power, however, cycles are not inflexible affairs which run straight up and down and repeat. If their rhythms were this simple, everyone would soon learn the timing and know when to buy and when to sell for a profit. The fact then is that while cycles are the major influence on price movements, they are also pliable affairs so that both internal and external forces can (1) distort their shape and/or (2) cause them to lengthen or contract into shorter pieces.

Because of this vulnerability to influence, every cycle version differs from the ones preceding, so that while a pattern of movement can be seen at times in the longer and stronger cycles, it may not remain constant and may appear to disappear or be covered up by other cycles and other influences. In this situation, it is important to remember that it is the symptom which has disappeared—not the cause.

Because of their adaptability to circumstance, cycles in the market are misunderstood and their characteristics are vague since they can be only poorly defined by simple statistical methods. For instance, the usual steps for determining a cycle's characteristics are: (1) to compile a string of continuous statistics long enough that many cycle repetitions could occur within the series; (2) break the string down into appropriate lengths so that the repetitions of real cycles will show by piling up at certain intervals and (3) average the characteristics revealed in the average cycles.

This method—averaging—however precise, doesn't always give a true story, since averaging some cycle versions is unreal. The average will be statistically true but



probably will show few of the characteristics. For instance, the 10-week cycle, which is a strong cycle with great amplitude, and hence influence, has many variations. In a bull market, the upward leg may run as long as nine or more weeks, and in a bear market the upward leg may shorten to as few as three weeks. The apparent duration of the cycle, also, may vary considerably in length due to extraneous influences.

Since things on occasion move fast in the market, it requires more than average accuracy to take advantage of a changing atmosphere, because the outcome will often hinge on an interpretation of a deviation from an average course. The main reason that averaging cycles is an unsatisfactory means, however, is that the longer cycles are basically unstable, since they stem from a combination of smaller cycles.

Cycles promise to bridge the gap to the future

Now the only real reason for working with and understanding cycles is because it seems possible with cycles to bridge the gap between today and the unknown tomorrows. This is because, despite their vulnerability to influences and to the alteration of lengths by these influences, cycles “beat” with a remarkable regularity when their nature and individual characteristics are taken into account.

The regular beat which cycles maintain can be so strong at times that it seems almost uncanny, since it seems to go against all logic and reasoning and is thus the basis for the cult of contrariety. For instance, as anyone experienced in the market knows, in an upward bull swing, particularly when nearing a top, a market will throw off bad news almost as if it were unheard. Also, when a rally has started upward from a bottom, the worst of bad news will cause no more than an intra-day depression of prices, as we saw in the cases of OXY and FCI in November 1967. On the other hand, when a market is headed down from a peak, the best of good news will be shrugged off and prices will continue down. It becomes obvious, from this action, that the motivations of cycles are deep-rooted affairs which are much deeper than surface indications warrant.

Especially in times of change, such as those mentioned above, it is necessary to understand the cyclical system and how it operates if prediction is to be more than a guess about the future. An understanding of cycles and their characteristics, particularly the regularity of their rhythms, thus promises to supply the one ingredient which alone makes a prediction meaningful—cycles promise to deliver the *timing* of future predictable events.

The four parts of the cyclical principle

The first thing needed for the understanding of cycles is that *the longer cycles are really “chords” of smaller cycles* and each of the smaller and/or larger cycles influences others within the chord, just as a C9th chord (C-E-G-B⁷-D) on a piano is a sound quite different from the basic C chord (C-E-G). In the cycle system, however, all the notes of the chord are playing at all times, but, as we shall see, in times of stress the shorter cycles become the dominant notes instead of the harmony of the longer chords.

Secondly, it is necessary to understand that *the longer cycles, in effect, provide a trend for the smaller cycles* since the changes of cyclical value from time-period to time-period in the longer cycles are small. That is, during the first half of the life of a



large cycle, the numbers in the progression from zero to one (or any value) are in smaller steps than the progression of the shorter cycles.

Thirdly, it is necessary to understand that, because these short-interval upward and downward steps of the long cycles represent very little change in value in a short time period, *the changes of influence exhibited by the longer cycles are minuscule in comparison* with the influence of a short cycle such as the 10-day, which oscillates from zero to maximum and back to zero in five-day swings.

Fourthly, it is necessary to understand that in a chord of cycles, it is possible that *a change in the rhythmic vibrations* (an offbeat sequence) *of a small cycle may cause an unharmonic combination* within the cyclical chord. When an event such as this occurs, one or more of the adjacent cycles will move slightly to a position, either longer or shorter, or of more or less amplitude, which is complementary to the new harmonic system. This can be demonstrated on your piano, where the addition of D to raise a CM7th chord to a C9th chord requires the movement of the B (in the C-major-7th-chord—C-E-G-B) down a half note to B[♭] in order to avoid a discordant sound.

On a piano, of course, we are the masters of the notes in the combinations. In the market, the variations are caused by extraneous events which cause large alterations in the smaller cycles, which have the greatest immediate effect. Over the long run, longer cycles retain their regularity, but over a short run sharp deviations of a short cycle can cause the longer cycles to adjust or at least give the appearance of adjustment. As we said earlier, cycles are invisible and we can only measure their effect on stock prices.

How market cycles adjust to discordant situations

One way this adjustment to new harmonics is made is for the longer cycles to break down into shorter cycles so that their power appears to disappear. For instance, in a C9th chord (C-E-G-B[♭]-D), the discord of a B-note disappears by (1) substituting B[♭] for B or (2) dropping the chord back to the CM7th (C-E-G-B) by dropping D, the ninth note. If a discord appeared in a CM7th, the chord could revert to a C6th by the substitution of A for B (a C6th is C-E-G-A), and if a discord persisted, the harmonics could be preserved by dropping back to the basic C-E-G or simply to a C itself. Longer cycles thus tend to disappear in an unharmonic atmosphere and the smaller cycles, or smaller chord of cycles, become dominant.

In the market, the 17-year (and a 3.42-year) cycle on occasion is nearly invisible on a long-range chart. In an unharmonic situation, the 17-year cycle may show up as four versions of the 4.25-year cycle. In further unharmonic atmospheres, the 17-year cycle may show only as segments of 17 months and, on occasion, as 25-week pieces. Within the framework of the 17-year cycle, it is thus possible that the 17-year influence will show only at the beginnings and ends of the periods and only as distortions within the center of the period.

The reason that the larger market cycles break down is the relationship of money (and/or profits) to the price of stocks. When a person buys or sells a stock, he is doing his best to anticipate what the price of the stock will be for as far as he can see into the future. People, of course, buy stocks for capital gains—or at least for the satisfaction



of being able to take a capital gain if they so desire—even if they won't admit it. By the same token most people are allergic to taking a capital loss, especially if they think the loss is only temporary.

Anticipation thus plays a vital role in the market—so vital in fact that it is *almost* possible to say that anticipation runs in cycles which are concurrent with market cycles. Anticipation, at any rate, comes in various lengths—long if hopes for the future are good and short if the outlook is depressing, especially if a stock has bloodied your nose. So cycles get longer when the future looks good and shorter if the outlook is depressing—but don't forget that the longer cycles, even though not visible, are still present and doing their bit.

III—A Synthesis Reveals the Market's Cyclical Nature

Tracking down a single cycle in the market is like finding Dr. Livingston in the jungle. You either have to be lucky or extremely knowledgeable, since, most likely, the cycle isn't where you think it is likely to be or is distorted, lengthened or shortened by economic events or by the interaction of adjacent cycles so that recognition is difficult. A synthesis, which combines the values of several cycles, however, when it is built from a combination of significant cycles, reveals that the market is basically cyclical in nature and, also, isolates the times when the market departs from a cyclical course.

How cycles performed in the discordant period prior to 1932

Now we have said that one of the reasons so little is known about cycles in the market is their shape is subject to alteration and their apparent lengths may break down into shorter periods if anticipation is short. The result is that sometimes you can't see the cycles for the cycles and the outside influences.

For instance, in Figs. 1.8, 1.9, 1.10 and 1.11, we illustrate on a monthly basis the history of the Dow Jones industrial average from its inception on January 2, 1897 through 1966. Assuming that the June 1932 low was a genuine cyclical bottom—because the horrendous 92% drop which culminated in that month must have been caused by an accumulation of cycles of all lengths—we use that point as a marker for projecting cycle lengths backward and forward in time. The heavy line on the charts indicates the "ideal" peaks and troughs of the 17-year cycle, and the lighter line indicates the same points for the 4.25-year cycle, which fits neatly into the 17-year length. The 17-year cycle, thus, would "ideally" trough in June 1915 and again in June 1898. From 1932, it should have troughed in June 1949, again in June 1966 and later in June 1983.

From our perusal of the chart in Fig. 1.8, we can see that there was a trough in the average in 1915 and again near the 1898 bottom. Actually, however, the real troughs of the market average appeared in April 1897, another in March 1898, another in November 1903, another in November 1907 and a final one in December 1914. The December 1914 trough may not be genuine since trading was suspended at the outbreak of World War I so that there are no figures from July 30 to December 12, 1914.



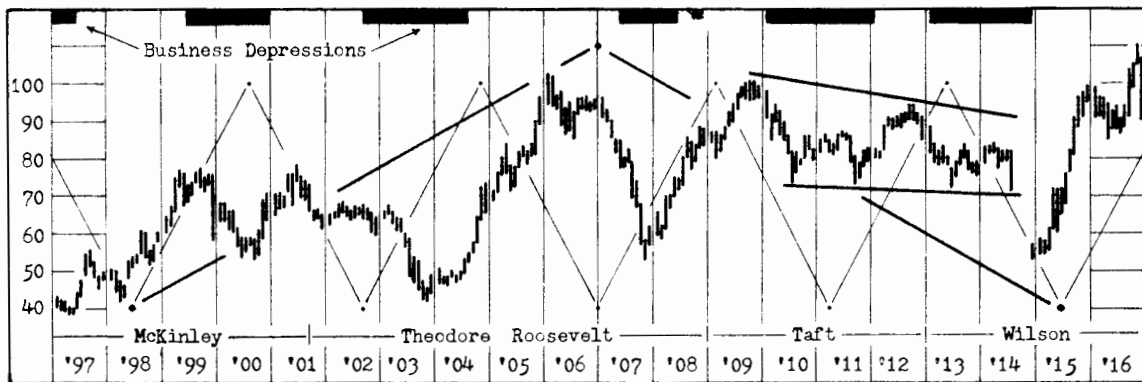

Fig. 1.8—The Dow Jones industrial average, monthly high-low closing prices, from the beginning in January 1897 through 1915.

Now we can also see from Fig. 1.8 that, just as the 17-year cycle did not appear in ideal form, neither did the 4.25-year cycle. Instead of bottoming in March 1911, in January 1907, in October 1902 and in June 1898, as would be expected from a projection of an average length, the bottoms appeared irregularly.

The same sort of performance occurred in Fig. 1.9 which shows the period from 1915–32. The peak of the market came, not in January 1924 as would be expected, but in late 1929. The 4.25-year cycle bottoms, as expected, were nowhere near the actual market bottoms in 1917 and August 1921.

How cycles performed in the 1932–66 periods of the 17-year cycle

Fig. 1.10 also shows very little correspondence between the “ideal” 4.25-year cycle and market performance, since the market peaked at what should have been a trough in 1936–37, troughed in April 1942 instead of January 1941, didn’t bottom at all near the 1945 trough—but it did manage to trough on time in June 1949, at the bottom, also, of the 17-year cycle in that month.

In Fig. 1.11, however, we commence to see some material evidence that there is a cycle as long as 4.25 years in the market. For instance, the trough in September 1953 was in perfect timing, the trough in 1957 was only three months early—the Dow moved sideways in a range during the troughing operation—and the 1962 trough came in June instead of March, as indicated by the “ideal” troughing indicator. The 1966 troughing, however, was on time, if the late bottoming in 1962 is taken as a measuring point. The 17-year cycle, bottoming with the 4.25-year cycle in 1966, was also three months late from the prepared timetable.

Now, as we have seen, a mechanical method sometimes leaves a great deal to be desired. Not counting the 1932 trough, the 4.25-year cycle never bottomed “on time” from 1897 to 1932; it bottomed correctly only in 1949 and 1953. The 17-year cycle bottomed early in 1898 and 1915, but was on time only in 1949, although it was only three months late in 1966.



Fig. 1.9—The Dow Jones industrial average during the 17-year cycle, 1915–32.

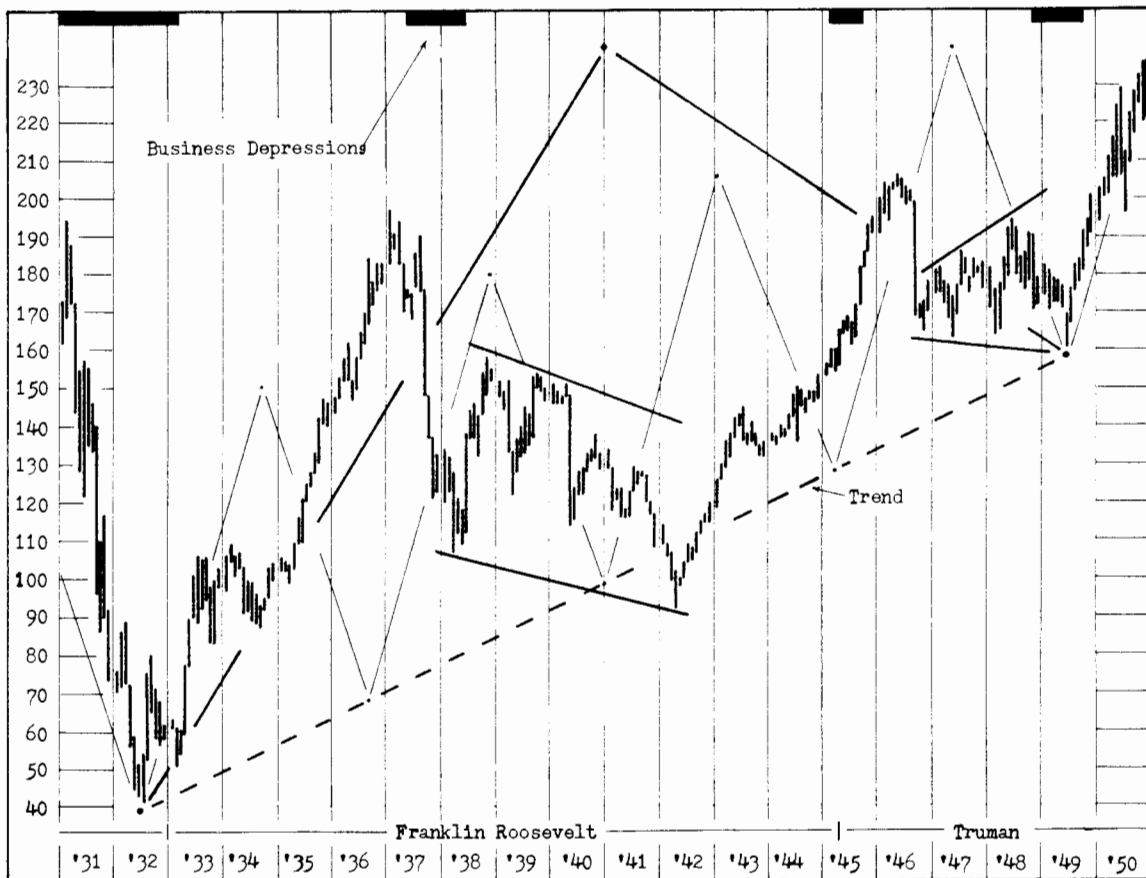

Fig. 1.10—The Dow Jones industrial average from the 1932 bottom to the beginning of the next 17-year cycle, 1949.

Since only those persons who are now retired, or about to retire, actually worked through any except the post World War II period of the 17-year cycle—and hence have more than textbook knowledge of the events of these times—let us look again at the early charts. The black rectangles at the tops of the charts indicate that there were many business “contractions” * in the era prior to 1932. These were genuine “depressions,” since, as we can see, they influenced the prices of the Dow average so that the entire period from 1897 to 1915 had a nearly flat trend. That is, the 1897 low was at DJI 39.13 and the prewar 1914 low was at DJI 53.17—a trend that sloped upward only 36% over a 17-year base, or slightly over 2% per year. If the DJI is a measure of business activity, as is alleged, business conditions fluctuated from 100 to 40 or a 60-point swing from boom to bust.

* As defined by the National Bureau of Economic Research, Inc.

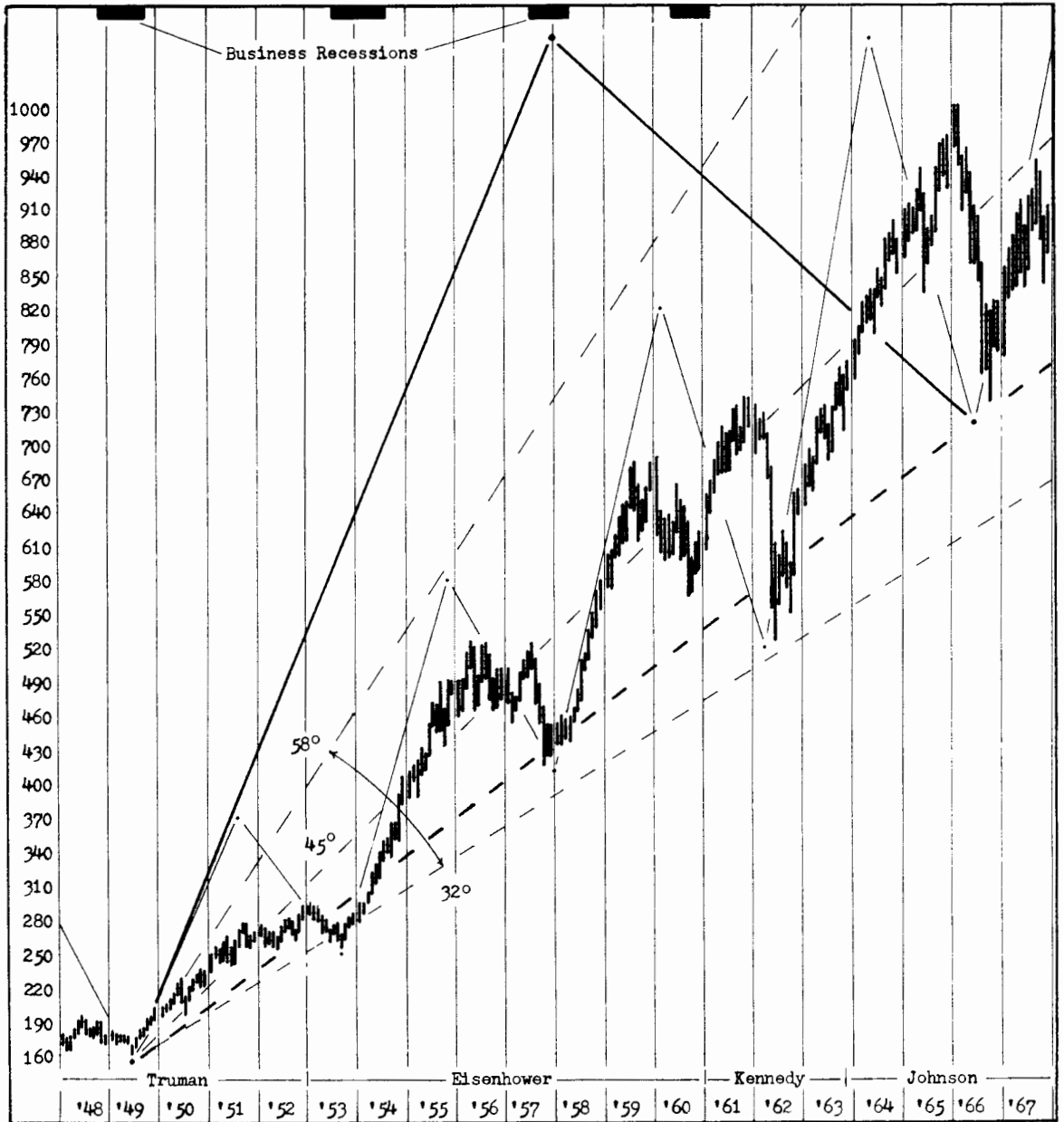

Fig. 1.11—The Dow Jones industrial average in the 1949–66 period of the 17-year cycle.

Much the same thing occurred in the 1915–32 era, the second 17-year swing of the cycles. Business and stock prices oscillated in much the same range as previously until, in 1925, the Dow climbed above its 120 previous high and began its ascent to the 1929 high close of 381.17. From here came the gigantic drop back to the 40 level (41.22 close) in July 1932, which was followed by The Great Depression.

Now we can see (1) that the state of business during these two 17-year periods caused the market to dip from its highs to its lows (or, as is now alleged, the market caused business to dip), so that the influence of business swings was present in the market as well as cyclical influences, and (2) that the business influence appears to be a strong factor in the market inasmuch as there were no regular cyclical bottomings of the Dow during these periods.

The relationship of business and stock prices is probably well known, but it doesn't hurt to repeat that the market and money are virtually the same thing. Money—or cash or bank credit—is immediately available. Stocks are now available in five business days. Stocks today thus are only five days away from full liquidity—cash.

The 17-year cycle divides business history into logical epochs

As we have postulated, when the outlook is cloudy or depressing, the effective lengths of longer cycles—which are really sums of smaller harmonic cycles—break down into smaller cycles. It is hardly surprising, thus, that the 17-year cycle, except for the beginnings and endings of its periods, is hardly visible in the charts—but before we dismiss the 17-year cycle as being unworthy of much consideration, we need to take a closer look at it since it is indeed an effective influence.

For instance, the first illustrated 17-year cycle was a relatively flat period so far as business was concerned, since the trend of the Dow average was nearly flat and the swings of the average, from 40 to 100 DJI, appeared largely unrelated to either the 17-year or the 4.25-year cycles. On reflection, however, we can see that there were tremendous changes in the U.S. economy—from a dominantly agricultural country to the beginnings of a fully mechanized country. The 17-year cycle in this version saw tremendous changes—it began with the Spanish-American war and ended in the turbulence preceding World War I. It marked the beginning of the swing of opinion from isolationism to the beginnings of a world power.

The second 17-year cycle, from 1915 to 1932, also witnessed tremendous change. During the first half of the cycle, the economy, as indicated by the Dow average, remained largely unchanged, but, finally, in the second half an inflationary psychology surfaced and the Dow climbed to astronomical heights—with an inevitable breakdown of prices to more realistic values. Our second 17-year cycle began in war and ended at the beginning of a tremendous business depression. Opinion swung from monetary ebullience to rank pessimism.

The third version of the cycle, from 1932 to 1949, included a recovery from the cyclical lows of 1932, a war-atmosphere depression and a wartime inflation of prices beginning with the entrance of the U.S. into World War II. The third version was distinct from the previous two but it also saw a tremendous swing of opinion from isolationism to a fullblown world power.



The fourth version of the 17-year cycle in the Dow's history was, as we know, a time of tremendous economic progress, and, in later years, of monetary inflation—so that prices of goods, labor and land had become grossly exaggerated when the cycle ended in 1966. Opinion in this cycle, too, underwent tremendous change—especially if the period from 1932 to 1966 is considered as a double 17-year cycle or a 34-year cycle.

If the basic changes of psychology—or opinions, or thinking, or attitudes—which we have outlined had come at irregular intervals of time, there would be no argument for the existence of the 17-year cycle. The fact that the dates of the regular troughings of the 17-year cycle have proven to be such excellent dividers between psychological epochs, however, is an indication of the potency of the almost anonymous 17-year cycle. The same can be said for the 34-year cycle if we think two oscillations prove the cycle. Certainly 1932 marked a cyclical low from 1898—and recent developments also appear to center around 1966. What may happen in 2000 A.D.?

How longer cycles break down into shorter lengths

As we have said, market cycles are subject to distortion from outside influences so that (1) their shape (or amplitude) may be warped or (2) their effective length may increase or break down into shorter harmonics.

In Fig. 1.11, we can see that the shape of the 1957–62 version of the 4.25-year cycle was distorted during 1960 when the Dow, instead of following an upward pattern which should have peaked in mid-1960, or, at the latest, in 1961, receded from the 1959 highs during most of the year.

In Fig. 1.12, we show, on a weekly chart basis, what happened to the 4.25-year cycle during this period. First we note that the market as portrayed by the Dow moved rapidly up from an October 1957 low of about 416 to a high of 684 in the third quarter of 1959. This peak was followed by a slightly higher peak (2) in the first week of 1960, and the second trough (3) in the first quarter of 1960 was lower than the previous trough. A third rally (4) in the second quarter of 1960 failed to reach the previous highs, but the final trough (5) in the final 1960 quarter reached a low which was lower than the previous two troughs. The market during this period was tracing out an expanding triangle formation, in which there are higher peaks and lower troughs for five revolutions of the short cycles.

Expanding triangles, as we shall see later, have a habit of developing a final thrust (rally) from the triangular base, which will often enough be twice as long as the final leg of the triangle. In this case, the prediction of the extent of the thrust rally fell short by 22 points, since the final downward leg was about 100 points on the Dow and the rally ran 178 from 564 to 742.

Now also on the chart of Fig. 1.12 are two black areas similar to those on the foregoing monthly charts, which indicate by their length periods of business “contraction” or “recession” as they have been labelled since World War II. The first period extended from July 1957 to April 1958. The second covered the period from May 1960 to February 1961. We can see from these black bars (1) that the first was responsible for the decline of the Dow from about 520 to about 420 at the end of the move, and that,



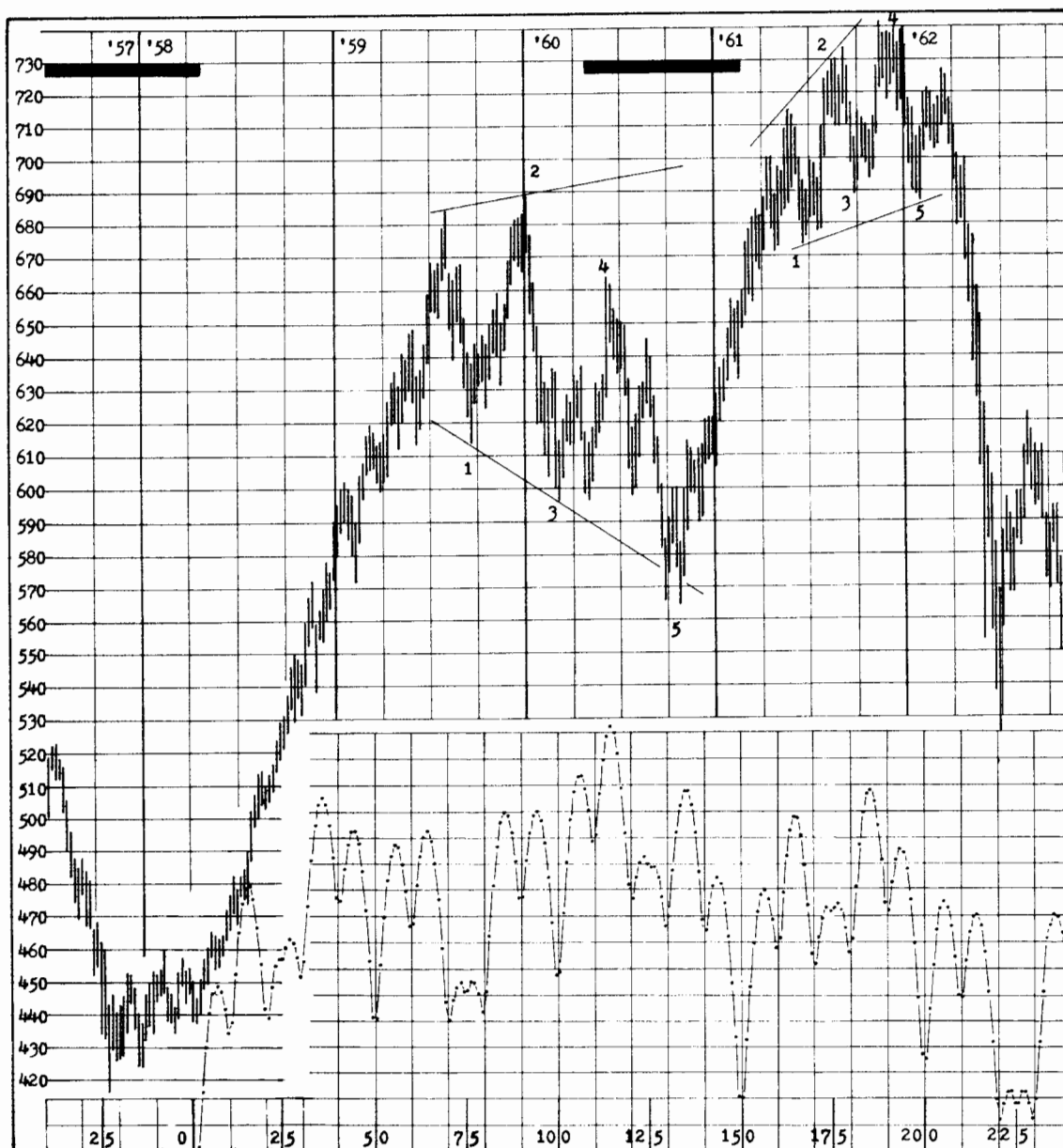

Fig. 1.12—Weekly basis high-low chart of the Dow industrial average during the 4.25-year cycle, 1958–62.

after the bottom, the Dow traded in a narrow range until the end of the recession period, and (2) that the second period of recession was anticipated in the first quarter of 1960 and its depressing effects lasted until the fourth quarter of 1960. In light of these economic indicators, it is interesting to see how our synthesis of five cycles fared during this period.

Placing the beginning of the 4.25-year synthesis at the beginning of the upward movement from the bottom range, in the second 1958 quarter, we see that the end of the synthesis coincides with the end of the downslide in June 1962. Now we also know that the 1957 troughing of the 4.25-year cycle was three months early when it bottomed at about 416 in October 1957. The previous trough came in September 1953 or just four years previous. From the chart, we can see that the market idled between 424 and 460 for almost exactly six months, and that, in the final weeks of 1957, the second bottom of the period at 424 was almost exactly 4.25 years after the 1953 September bottoming.

Also we note that the June 1962 bottom was eight years and nine months from the September 1953 bottom. We now know that the extra length of the 1962 cycle was caused by the recession period which lasted through the first quarter of 1958. That is, from the beginning of the cyclical upward movement in April 1958 to June 1962, the period of the cycle was almost perfectly on time—four years and three months. We also know, from Fig. 1.11, that the following 4.25-year cycle ended in October 1966—or four years and three months from the 1962 bottom. The 4.25-year cycle thus was three months behind schedule at the 1966 low because of the 1957–58 recession period.

As we said, in times of outside pressure, longer cycles in the market will break down into shorter lengths. Looking at the synthesis pattern at the bottom of the chart and relating it to the track of the Dow, we see that the first dip of the Dow, after the long rally from the bottom, came in almost perfect coordination with the week 75 marker of the synthesis. In the triangle, the first (1) and second (3) troughs were almost 24 weeks apart, also in consonance with the synthesis pattern, and the final trough (5) came 29 weeks after the second trough, at week 130 of the synthesis. The triangle was 53 weeks or two 25-week-plus cycles long.

In the second (topping) triangle—which, of course, broke down instead of thrusting as would have been expected—the first (1) and second (3) troughs are also almost exactly in time with the week 175 dips of the synthesis, and the final trough of the triangle (5) is timed with the week 200 dip. The final small rally, which should have been a thrust, was aborted, but the market bottomed 21 weeks from the beginning of this rally in early 1962.

In this example then, we can see evidence of the 4.25-year cycle, the 17-month cycle*, the 25-week cycle and the 10-week cycle. We also can see that while each of

* Confirmation of a 17-month cycle in the market was reported in September 1969, in *Cycles* magazine. A computer reconnaissance analysis indicates a possible periodicity of 17.23 months (74.66 weeks) with an amplitude of 2.61% from a 17-month moving average trend. Gertrude Shirk, *Cycles*, Vol. XX, Number 9, pp. 210–220. Copyright © 1969 by the Foundation for the Study of Cycles, 124 South Highland Ave., Pittsburgh, Pa. 15206. The Foundation is a not-for-profit, tax-exempt scientific and educational membership organization.



the cycles in the synthesis was evident in the Dow formation all of the other cycles also were present, especially the 4.25-year cycle.

How the 4.25-year cycle of 1928–32 broke down into 17-month lengths

A cycle which fails to repeat itself at regular intervals is probably not a cycle at all, but a freak occurrence or a “random,” so let us seek corroboration of our findings at an earlier period in the charts.

In Fig. 1.9, which shows the Dow during the 17-year period 1915–32, we found very little apparent evidence of a 4.25-year cycle. There were no troughings in time with the cycle markers and only a hint of a peak at an “ideal” cyclical top in 1926. A little closer study, however, reveals that the 4.25-year cycle was there and working—especially during, of all times, the final version in 1928–32.

In Fig. 1.13, we see a weekly chart of the period beginning in 1927. We know from the chart of Fig. 1.9 that the period from early 1926–7 should have been a downward leg of the 4.25-year cycle. Instead there never was a really visible letdown from the 1926 peak to the 1929 peak. Let’s see what happened as revealed by the weekly chart.

First, by placing the end of the synthesis at the June 1932 bottom, we see that the cycle actually began in the first quarter of 1928. We also see that the 1929 peak of 380 occurred almost exactly 17 months from the beginning of the cycle (despite the appearance of an expanding triangle in the first and second quarters of 1929). We also see that the secondary peak of 294 in the third week of the second quarter of 1930 was in consonance with the synthesis peak in weeks 112–3 and that the first decline from the peak ended at the beginning of the week 150 period, and, further, that the final bottom of the market occurred another 75 weeks later at marker 225. The 1928–32 market breaks up nicely into three consecutive 17-month periods.

The first 25-week period of the cycle, in the first and second quarters of 1928, was a so-so affair in which the Dow climbed from the cyclical trough of about 192 to a high of about 222 and declined in consonance with the synthesis at week 15. The following 10-week period saw some rise—to 240—but the next 20-week thrust carried the Dow to a peak of 322 in the sixth week of 1929. From here a small 21-week triangle formation built up with the second trough six weeks after the first and the third trough nine weeks later, since the market was under extreme pressure. The thrust from the triangle—which, incidentally, carried 86 points, or more than twice as far as the final downward 34-point leg—ended at the trough of week 75 of the synthesis.

It is to be noted that the violent drop from the peak—the gapping week—came at the end of week 85 and that the secondary peak of 294 was 25 weeks from the gapping drop.

How the five-cycle synthesis matches weakness in the DJI

Weeks 65–85, 115–135 and 165–185 also provide interesting areas in the chart. First, the gapping drop from the top in the 85–86th weeks came in the synthesis formation, which resembles a jagged-Y () with the tail centering on week 75. This same formation repeats, with the tail centering on week 125 and again on week 175. We note a similar tendency in the formation centering on weeks 25 and 125. Referring

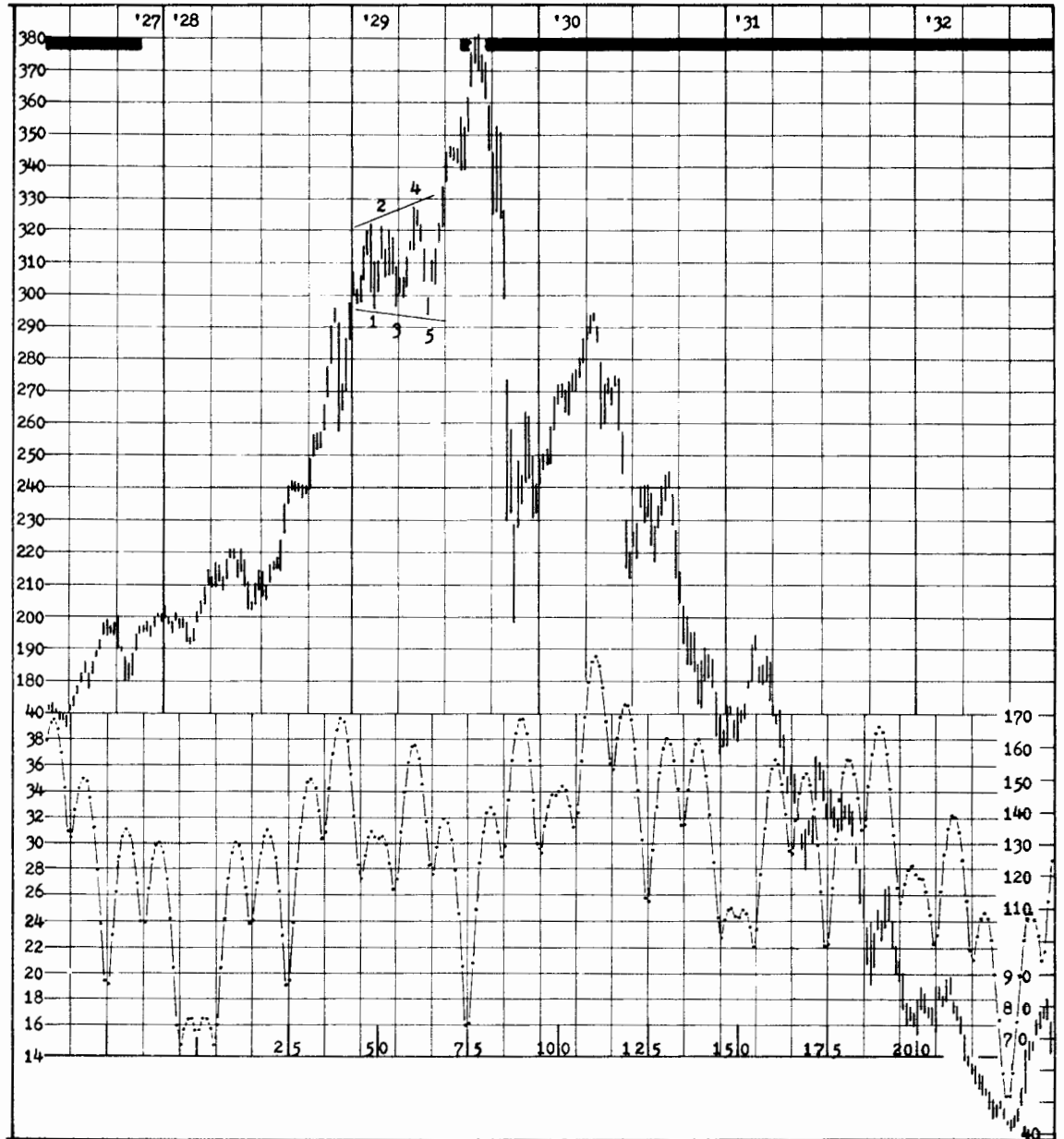

Fig. 1.13—Weekly basis high-low chart of the Dow industrial average and the 4.25-year cycle, 1928-32.

to Fig. 1.12, we can see that these periods (centering on 50, 100, 150 and 200 in this chart) are also times when the Dow is weak, particularly in the 210th week which set off the 1962 drop.

Now, as we note, the numbering of the formations in the charts of Figs. 1.12 and 1.13 is different. That is, the week 150 troughing of the synthesis in Fig. 1.12 is the same pattern which is numbered week 75 in Fig. 1.13. The reason is that the 225-week synthesis can return to zero only in the 450th week because of the action of the short cycles in the synthesis. In the 225th week of the pattern, the long cycles (225-, 75- and 25-week) are at zero but the 10-week and the 10-day cycles are at full strength, so that the low of the synthesis comes in the 220th week—instead of the 225th week.

This creates a situation whereby the synthesis actually becomes a double synthesis. In Fig. 1.7, we notice that the numbering of the phases of the synthesis reaches the 225-week length and then reverses so that the 25th week and the 425th week are the same. Over a 450-week length, thus, we have two versions of the cycle—one of which is a back-to-back copy of the other. For instance week 200 and week 250 are the same, as are weeks 150 and 300, but in the second half of the double synthesis, week 300 is only 75 weeks from the beginning of the second half.

The 8.5-year cycle is a double 4.25-year cycle

There are two reasons why the synthesis was constructed this way: (1) We shall find that there are many examples in the market of double cycles, in which the cyclical strength is such that the second cycle never returns to the levels of the beginning of the first half until the second cycle has reached week 450 (for instance, the 1957–58 and 1966 bottoms were pinpoint bottoms, the 1953 and 1962 bottoms were not). (2) There is plenty of evidence at hand to support a theory of an 8.5-year cycle in the market, in commodity prices, in department store sales and even in the size of the sheep population—a subject which we shall not go into since, in our opinion, the 8.5-year cycle is not much more effective in the market than the 17-year cycle. It is enough to be aware of the probability. It is present, as can be seen, when you look knowledgeably at the charts of Figs. 1.8, 1.9, 1.10 and 1.11, but its influence is mainly concentrated in the troughing areas of the cycle.

In Figs. 1.14 and 1.15, we give the double-cycle synthesis a chance to display itself. The first half of the chart (shown in Fig. 1.14) contains most of the synthesis, from zero to 200, and the remainder of the synthesis is shown in Fig. 1.15. Once again, a picture of the period from 1897 to 1907 in Fig. 1.8 looks like a most unlikely spot to find any longer-length cycle. The first swing ran from 1898 to 1903—nearly six years—and the second swing of the average ran from 1903 to 1907—just about four years. Also we see that the first cycle had two peaks more than a year apart, so that the first cycle was apparently two swings of, first, a little over two years and, second, a little over three years, and then was followed by a four-year swing from 1903–07.

When we refer to weekly charts, however, we see that the cycle actually began in the first quarter of 1899. This measurement derives from the troughing of the DJI in the final quarter of 1907 and extends backward in time for 450 weeks, to the first quarter of 1899. Now, as we can see, the only market bottom in this period came at the end

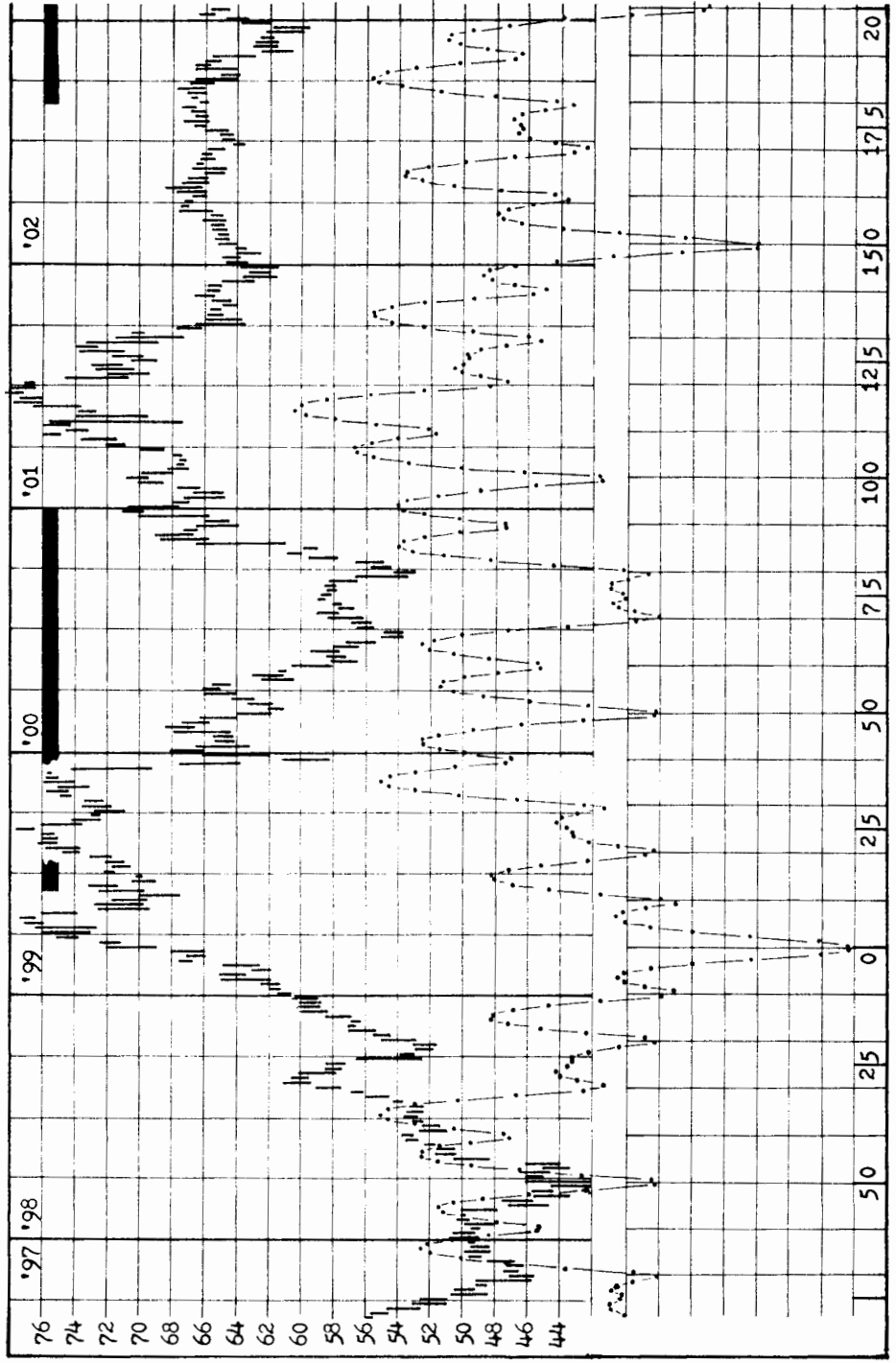

Fig. 1.14—The 4.25-year cycle, 1897–1902. Weekly basis high-low closing prices of the Dow industrial average.

of the first quarter in 1898. By extending the synthesis beyond zero, however, we see that the 1898 bottom was just 50 weeks (two 25-week periods) previous to the spot we have picked as the beginning of the 4.25-year double (or 8.5-year) cycle. The next thing we notice is that the market, instead of troughing at the zero week, actually hit a new high in the fourth week of the second quarter, 1899. The synthesis and the market, thus, were in time, except that one or the other—we choose the Dow—was inverted, so that the trough of the synthesis became a peak in the market average. The inversion was due to volume. (See Fig. 2.2, p. 74.)

Now after this first peak, we see that the market went sideways, with DJI 77–78 the top for almost three quarters. The drop from this top range coincided with the first “V” in the jagged-Y formation, and from this peak the Dow came down until week 70. Another trough at week 80 coincided with the synthesis, and from this low the Dow went upward until week 120 (with a weak period in the second “V” of the jagged-Y formation). After the descent to week 145, the industrial average went sideways with only minor movements until the first quarter of 1903, bottoming finally in the last quarter of the year.

The big rally from the 1903 trough got under way at about the 50th week of the second synthesis and continued upward until early 1906. A new double bottom coincided closely with the week 145–155 area, and the market rallied and then went sideways into 1907. The downslide from the end of the range took slightly more than 40 weeks—or four 10-week cycles—to accomplish.

How to position the five-cycle synthesis correctly

As you may have noticed, we usually pick a trough at either zero or at week 450 as the point from which to project in either direction, as we did in the preceding charts. The reason is that the week zero and week 450 troughings are pinpoints where a nearly exact placement for the beginning or ending of a double cycle can be made. The end of the first half of a double cycle, as we have noted, encompasses a 10-week area from weeks 220–230, whereas the week zero and week 450 pinpoints are quite exact.

Assisting us in this selection of troughs is the knowledge that the 1932 trough was on time and was of itself a pinpoint trough. Our placement of the double-cycle synthesis thus must find the 8.5-year pinpoint troughings at areas near the first part of 1924, near the center of 1915, near the beginning of 1907 and near the middle of 1898—or find a good reason why the double cycles should not have pinpoint troughs at that time. Our selection of the 1907 trough (caused, incidentally, by the 1907 money panic, according to historians and writers of the time) as a pinpoint instead of a flat bottom (between weeks 220 and 230), thus, was not inadvertent. Neither, of course, was the 1957–58 pinpoint, since this bottom was three revolutions of the 8.5-year cycle from the 1932 trough.

Looking at Figs. 1.14 and 1.15, we see that the economic scene is also portrayed in the black bars at the top of the illustrations. The depression which ended in late 1900 at first had little effect on the cyclical movement but later the Dow dropped (with the synthesis). The second depression of 1902–04 at first was disregarded but later caused a drop in the Dow (in consonance with the cycle structure), and it delayed



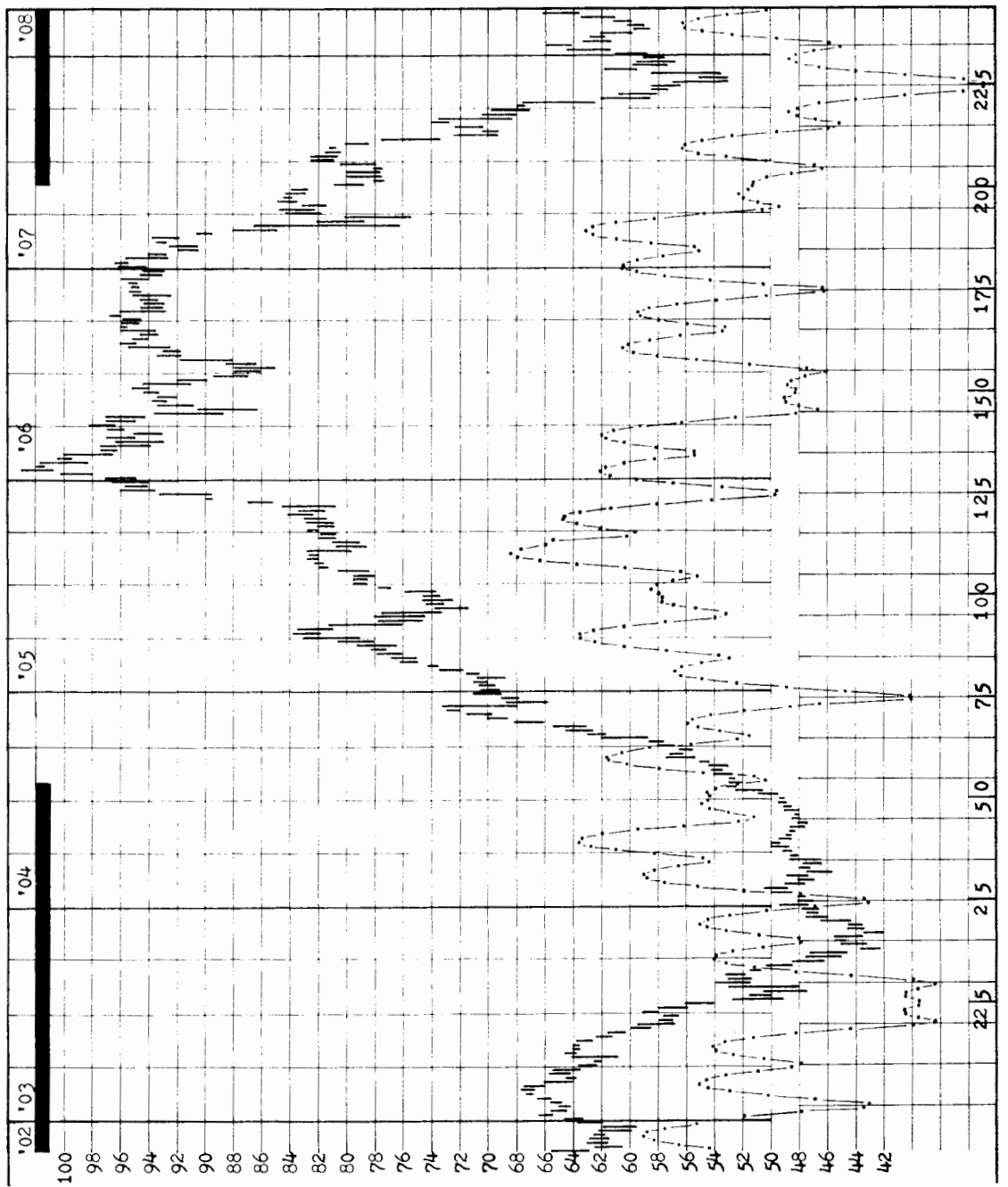

Fig. 1.15—The Dow industrial average in the second half of the double-cycle, 1902-07.

the upward movement of the cycle from the final quarter of 1903 to the beginning of the third quarter of 1904. We can see also that the real reason the market did not trough in late 1902, instead of late 1903, was the tight range of prices which lasted throughout the whole of 1902. If this area is eliminated, the cycle would have troughed in late 1902, in conformity with our “ideal” timing, and the 4.25-year cycle of 1902–06 would have troughed in perfect time with the “ideal” 1906 trough—providing you believe cycles are often more important than economic events as a cause of market movements.

Cycles establish the timing for future probable events

Now we wish to emphasize that the cycles—and the cyclical system—which we have seen in the examples are *price cycles*, since no consideration other than the “price” of the Dow industrial average was involved.

This is important because price is a major consideration in the market, and, if it shows a tendency toward a regular rhythm, as it does, it becomes possible to forecast the timing of future price changes. Please note that we say timing, since this is the principal virtue of price cycles—establishment of the timing for future probabilities—because prediction which is not tied down to specific dates is useless. Also please note that we say future probabilities, since there is a chicken-and-egg connotation in “future events”: It is a big question whether cycles are a reflection of events which transpire or whether events transpire in reflection of cyclical influences, because *it is only rarely that the cyclical system is thrown offbeat for more than a short period by random events.*

In any event, it is well to have at hand a timetable for the future on which to base our plan of action. For instance, there are constantly present in the market, price undulations in individual stocks, as we saw in the actions of OXY, FCI, CNV and an average of stocks. Some of the undulations, both large and small, are genuine cyclical movements and some are the result of intra-day and other tick-rhythm idling away of time. In an active stock on a busy day, for instance, it is very difficult to determine which is the wheat and which is the chaff of the movements—but being able to ascertain immediately and certainly which is which is the millstone on which profits can be ground out.

When we have established the validity of cycles in the market—and the synthesis method which allows an “educated” study of actual price movements is one of the best—the next step is to determine why the actual market departs from the synthesis or, for instance, why there was an inversion of the average in 1899, the final rally to the peak in 1906, the inversion in the third quarter of 1929 and the 25-week delay in the beginning of the 1957–62 rise.

Besides price, there are two principal forces in the market and both have an effect on price. The first is the economic trend of the nation’s business, which, as we have seen, appears to distort cyclical swings at times, and the second, if only by virtue of elimination, has to be the volume of transactions, as we shall see in Chapter 2.

Before we leave price cycles, however, we must note that the synthesis which we evolved is in no way a valid forecaster nor is it connected with the amplitude of price cycles, or the amount of swing above or below a trendline or center value. All we can expect from a mathematical synthesis is a model by which to measure and study past rallies, recoils and interim periods in the market. It is needed because of the inter-



action of adjacent cycles upon each other, as well as other disturbances. That is, as we saw in the illustrations, a single cycle is very difficult to trace in the Dow average, but, when we combine the influences of several cycles which are potent in the market, a combination of cycles unravels a lot of loose ends and isolates those areas which appear to be anti-cyclical for further study.



The Forces and Framework of the Cyclical Structure **2**

There are three laws of physics which apply also to cyclical behavior. These are Newton's laws of motion, which state, first, that a body left to itself will maintain its condition unchanged; second, a change in the motion of a body indicates that a force is operating and, third, for every force there is an equal and opposite reaction.

That these laws apply to price cycles in the market is observable: (1) Unless there is a force (volume), there is no price movement. Price is static until it moves in response to one or more transactions. (2) When a stock price changes direction, it is indicative that a force has caused the change—or that a buyer has succeeded a seller, or vice-versa. (3) We can therefore conclude that there are at least two equal and opposed forces in the market—buying and selling.

With this in mind, it is apparent that before we can understand how and why prices move in the market, we need to understand (1) the nature of the forces involved and (2) the framework or mechanism against which the forces are applied.

1—The Nature of the Volume Forces

The force which powers price movement is the volume of transactions in the market—or, simply, volume—since it is obvious that price moves up or down principally in response to the increase or decrease of the quantity of volume—or demand and supply.

Basically, volume is a count of the number of shares of stock traded. When a stock trades actively on an exchange, its price moves in a range between the high and low prices of the day, and the day's volume in the stock is a count of the number of shares which were traded within that price



range each day. Price and volume thus are closely related—this is especially so because price without volume has no meaning. An asking price for a stock can be any figure, but the further it is removed from past transactions, the more ridiculous it becomes. Price is meaningful only when it represents a price at which a trade was made, or when it is within a frame of reference made reasonable by volume.

Besides this relationship of price and volume, there is another. This is the unit-to-unit relationship between price movement and volume. It springs from the basic trade in the market (100 shares is called a round lot), which usually causes either an upward or downward movement of price and sets up the tick-rhythm movements we saw in Chapter 1. From this movement of price, we can determine from exchange tapes or a record of transactions whether each trade resulted from a buy (if the price moved up) or from a sell (if the price moved down), so that the character of each piece of volume can be established. Since each trade is counted only once, despite the fact that the buyer bought 100 shares and the seller sold 100 shares, volume is never a standoff situation. It records in concrete figures the balance between buying and selling forces at any moment or over a day's trading.

Some people have alleged that the role of the individual in the market has decreased in recent years since the individual now represents a smaller portion of total volume than previously—because institutional trades have gotten larger and more frequent. As any tape reader knows, however, and as any perusal of block trade listings will quickly establish, block trades *generally* tend to follow individual trades. That is, block trades are made at prices close to “market” * price, so that, despite the impact of the size of a transaction, price usually remains on a very even keel. The impact of block size, thus, is minimal on price, for the most part, so that the basic 1-to-1 price-change/volume relationship is largely undisturbed despite sometimes exceeding quantities of volume.

In order to better understand the price-volume relationship and the resultant price cycles, we have to look at some very basic relationships between price and volume—so basic, in fact, that we must resort to analogy, since only the results are measurable in the market.

Stock flows from seller to buyer

Cycles, like electricity, are created from the basic attraction of oppositely charged bodies for each other.

In the case of electricity, the attraction of the opposite poles arises from the negative pole of a battery having an excess of electrons and the positive pole of a battery having a deficiency of electrons. When the two are connected by a circuit, such as a light bulb, the electrical current, which is the passage of electrons along a conductor, flows from the negative pole, which has the excess of electrons, to the positive pole. This flow will continue so long as the negative pole has an excess. When a battery is “run down,” both poles have equal amounts of electrons.

* Market price is current price or the price at which a normal trade can be executed at any moment. It may or may not vary from the price of the last trade. If it does, it will usually be close, except in unusual circumstances.



In the case of the market, the attraction of buyers to sellers results from the fact that the negative pole of the market, the sellers, has an excess of stock and the positive pole, the buyers, has insufficient stock to suit its desires. When the two poles meet, through the mechanism of a central exchange, stock passes from the negative pole to the positive pole, and the flow will continue so long as buyers feel they have a deficiency of stock or until buyers and sellers have equal amounts. When buyers accumulate a surplus of stock, they become sellers and their identity changes from positive to negative.

The flow of volume measures buying desire

In the market, in addition to the flow of stock from pole to pole, there is a third element which is not present in the electrical equation. This element is price, and since price moves largely in response to immediate demand and supply, we can judge from the price movement whether there is a deficiency of stock in the hands of buyers or whether there is a surplus of stock in the hands of sellers. Price allows us to “test” the balance of supply and demand in the market, just as a service man can test a battery and tell us its condition.

Now prices will not move when both buyer and seller are satisfied with the amount of stock they hold, or when the poles are in equilibrium, just as a light bulb will not light when a battery has a balance of electrons between the poles. When volume is running high, when there is a large flow of stock, we know that there is a large desire on the part of buyers to own stock. When volume is low, we know that buyers have about all the stock they want. The movement of price tells us which pole is dominant—the buyer or the seller—and the flow of volume tells us how much buying desire is present, since increasing volume is bullish for prices, indicating further desire for stock on the part of buyers, and decreasing volume is bearish for prices, indicating that desire for stock is diminishing.

How the cyclical field is formed

Now since, as we have seen, volume is a crucial element in the cyclical system, it becomes apparent that we must have some idea of where volume originates and its relationship to price so we can know roughly where stock will come from when prices move up and down. To understand this relationship, we also must have a simile, and this we find in the market's cyclical field—a field of force which we feel is strikingly similar to a magnetic field.

Magnetic field forces are illustrated in a high school physics experiment in which a bar magnet is placed under a glass or other smooth surface and iron filings are scattered on the surface. The filings move toward the nearest line of force of the magnetic field until they form a series of lines (curves) of force which extend across the field in a converging rainbow pattern. The curves which are closest to the axis of the magnet are the strongest magnetic forces, as physicists know, and those which form larger ellipses across the axis are the weakest of the magnetic forces. At the center of each curve—or equidistant from each pole—the positive and negative forces of the field are in balance or equilibrium.

The cyclical field, illustrated in a schematic drawing in Fig. 2.1, is similar to a



magnetic field set up by an electromagnet, instead of a bar magnet. Since both fields are traversed by the same curves of force which fan outward from the axis, an electromagnet differs from a bar or permanent magnet only in that an electromagnet is made by passing an electric current (a flow of electrons) through coils of wire which surround each of the two poles of the magnet. The cyclical magnet is formed when a flow of stock passes around the poles of the cyclical axis. The cyclical field, thus, activated by the flow of stock, forms around the cyclical electromagnet.

As we can see in Fig. 2.1, there are three elements present when a cyclical field is formed by a flow of stock: (1) the bands of force which fan outward from the axis; (2) the flow of stock from seller to buyer along the axis and through the striking zone of the market—where bargains are struck—and (3) the rays which arise in the striking zone and extend across the field.

For instance, when a stock is being sold in the market at prices around \$20, as indicated by the chart scale of Fig. 2.1, this enhances the desire-to-sell of other holders who are also anxious to sell their stock—but at higher prices than the market price. Some of the holders will be willing to sell at \$27, and some will put in actual orders while others will put in mental orders or alert their broker. If \$27 is a price at which a number of holders wish to sell, a band of orders will stretch across the field at a price of \$27. Others who want to sell at higher prices will also enter orders at the higher prices, and at each price zone (whether \$32, \$37 or \$42) where there are sufficient holders willing to sell at about the same price, a band of force will form. Now from the opposite pole—the buyers—pricebands will also form and curve upward until they meet the pricebands of sellers. The buying pricebands, just like the selling bands, will range from the reasonable to the ridiculous and cover the whole spectrum of the cyclical field, from the bottom to infinity.

When this process is completed, two forcebands—would-be buyers and would-be sellers at specific prices—will confront each other at the center of each band, and the two forces will be at equilibrium. At the center of the pricebands, then, the two forces will be equal and opposite—and static—since no transactions can take place at these levels, which are away from the market price.

Why people will pay high prices for stock

It is easy to see why sellers are anxious to get higher prices for their stock but it is a little difficult to see why anyone would pay \$35 for a \$20 stock, but that or worse happens in an upward cycle.

Most of the reasons why people will pay high prices for stock fall under three headings: fashion, fundamentals and fiction.

If a stock is fashionable, like electronics, computers, nursing homes and conglomerates have been in the past, people will buy a stock in an industry because they think they see a tremendous future for the stock and/or the industry. The growth of the industry may already have been tremendous, but everything they read points to further growth, and, of course, to higher prices for the stock, since the tendency to extrapolate straightline trend is ubiquitous in the market. Growth, as has been demon-



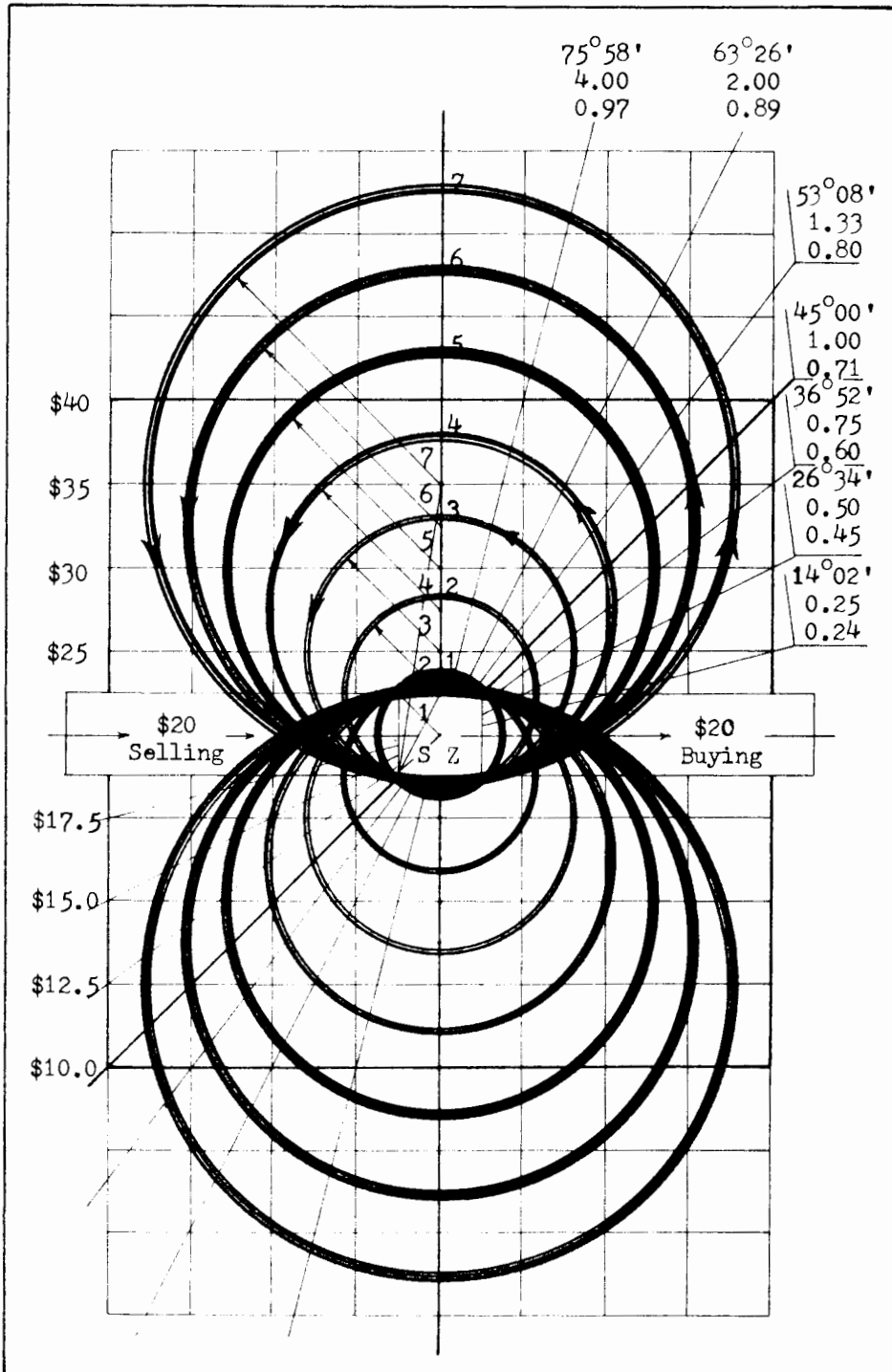

Fig. 2.1—A schematic drawing of the market's cyclical field of force.

strated for many years by the Gompertz curve, is not straightline but asymptotic*—that is, it never quite gets to where it figures to be and, unfortunately, it slows down about the time it gets halfway to its objective.

Fundamentals of a stock also lead to delusions. One theory of the “value” of a stock is that “worth” of some sort is the equal of all future dividends or, for the more conservative who dislike extrapolating to infinity, for a given number of future dividends and/or earnings. Other theories also are based on the “value” idea. “This stock has a very low P/E . . . This company’s earnings increase every year . . . These people have a ‘new’ technology . . .” If this sounds familiar, you are “hooked” on fundamentals and much prefer to determine what a company is “worth” to you than to watch empirically the movement of price, which, after all, establishes a market value sufficiently accurate for probate courts and for the IRS.

The worst “hooker” of all, however, is fiction. If someone tells you “you can’t go wrong on XYZ,” you can bet on a couple of things: (1) He bought the stock a lot lower than it is now and is happy with his profit. (2) He doesn’t know a bit more about the company and its prospects than you do. (3) He heard about it from someone else who probably didn’t know much about it either.

In addition to people who buy for “reasons” there are people who confuse the present with the future. These people want to be sure the market is going up before they buy and will forego a purchase at \$20 and buy at \$35, since, to them, a \$35 price indicates that the market is going to continue upward. They neglect the fact that a 75% rise in price is a lot of cyclical movement, and about all many stocks can stand without a major recoil. These are the people who have a single idea in their heads—hope. An electronic computer is said to be modelled after the human brain. Unfortunately, some people’s brains seem more to resemble solenoids than computers. The bolt of hope slams into place and the door is locked to further entry of what might be confusing facts.

Another reason people pay high prices for stocks is “pocket burn.” When people suddenly find themselves with cash, they are uncomfortable. They want their money to make money for them *now*, regardless of what the market situation may be. Fly now, pay later.

However, the really basic reason people are willing to pay high prices for stock is “market price delusion.” If you want a stock, you have to pay the price—and in a bull market, if you don’t pay the price you don’t get the stock, as a rule. Since all things are relative to the times, when the market is “good” prices are high, and we delude ourselves into thinking high stock prices are reasonable.

What happens to create this delusion is that the curtain of price, represented by the price scale at the left of Fig. 2.1, moves down behind the cyclical field framework so that the small numbers disappear off the bottom of the frame and larger ones come

* One dictionary describes an asymptote as “a straight line that continually approaches a curve, but does not meet it within a finite distance.” With cycles, it is easier to conceive of a curve approaching a straight horizontal line which acts as a ceiling or floor for the curve.



into the picture. This gives the delusion that the striking zone of market price has moved up, but the reverse is really true.

Quite often when you see two things that appear to be moving in relation to each other, you can't say for sure which one is moving and which one is stationary. In this case, however, it is the cyclical field framework which is stationary and the backdrop of price scale which moves down. That is, if we consider that the field is stationary, we can see that price moves—but oppositely from what we expect. The change is largely confined to the numbers on the grid of the price scale—which get larger when the background moves down—because we are looking through the frame of the cyclical field. The picture looks the same as before, but the small numbers, which were previously in the picture and were correctly identified with value, have disappeared and been replaced by larger numbers. At this point, the market has lost its value base. At the peak of a cyclical swing, there are no values left in the market—only high-priced stocks.

The illusion makes you forget that the stock you want to buy has sold at \$20, and at \$40 it looks quite reasonably priced and in the center of its range because, unbeknownst to you unless you look around a little, the pricebands which extend upward from \$40 have taken the place of the lower ones that were there before. Stock that was trading at \$20 and had pricebands up to \$40 now is trading at \$40 and has pricebands up to \$60. In this delusionary setting, a buy at \$40 looks to be as potentially rewarding as the purchase you could have made at \$20—since hope springs eternal.

Why the closest pricebands in the field are the strongest

As in the magnetic field, the pricebands which form closest to the striking zone of the cyclical field are the strongest forces, and those which form at prices further from the zone are the weakest forces. There is another side to the question, however, since those bands which are closest have less amplitude of price range than those which are further away from the market price.

A powerful magnet will pull an iron filing toward it from a considerable distance, and, as the filing approaches the magnet, the magnetic forces get stronger and stronger and the speed of the filing toward the magnet increases as it is drawn nearer. The magnet of the market, the transactions taking place in the striking zone, works the same way.

The pull of the market is strongest on would-be buyers and sellers who are thinking of prices closest to market price. Someone who is thinking of selling a stock a point or so away from the market is a close observer of market action, because if he is to get his price he must have an order “in” or must enter an order before the price turns downward, since, as we know, prices oscillate. Because this pull of desire to obtain a close-at-hand price is a very strong one, persons closest to the market price are most likely to accept a price which is close by. Very few of them will wait for a further price increase before selling or buying, since they have already made—or are about to make—a decision, for reasons of their own.

It is only when striking zone market prices have moved upward (because of the



downward price scale movement) that they come closer to and intrigue would-be buyers and sellers at higher price levels, just as the magnet's field of greatest force attracts faraway filings only when the filings are moved closer to the field. Since these persons have, for reasons of their own, established the higher prices as those at which they would be willing to buy or sell their stock, they do not actually become involved in decision making until the market price has moved upward and is nearing the price they have in mind.

The force of a cyclical price swing thus is strongest in the closest pricebands and weakest when it involves pricebands which are farther from the original striking zone level, since these bands will become involved in the magnetism of market price only when market price has moved close enough to bring them to market. The closest pricebands are the strongest and the farthest are the weakest—until the upward movement of market price brings them closer to the band. Also, as these higher pricebands get stronger from the approach of market prices, new, higher and weaker bands continue to form upward from the striking zone.

Volume flow determines amplitude and length of cyclical swings

The second element of the cyclical field structure, as distinguished from the mostly static forcebands of would-be buyers and sellers, is the activating element or the volume of transactions passing through the striking zone of market price. This volume arises from three principal sources: (1) the fairly constant volume from traders (and specialists) who buy or sell for short swings and keep the market active, liquid and limited in range; (2) the potential volume which flows from the forcebands of the field as they are liquefied by the magnetic effect of striking zone market price moving up or down toward the forcebands and (3) the volume additive which arises from new money drawn into the market by the magnetic movement of price.

Roughly, we can identify cycle lengths and amplitude with each of these three volume sources.

The small oscillations of price caused by the trades of short-term traders are the basic cyclical movements of the market and are those from which other cycles originate. Since the quantity of trading stock is relatively limited, the price swings of these cycles are also limited. The force which these trades exert on stock prices, however, is the strongest, relatively, of all volume forces. That is, just as the closest bands in the magnetic field are the strongest, the swings of price in response to the force of traders are the sharpest. For instance, in an upward movement, price will often skyrocket from an excess of demand over supply-of-the-moment. Part of the demand arises from traders' observance of price movement in a stock and the desire to own a share of a rising stock—a target of opportunity, in other words—and part of the demand comes from traders who are short the stock, or those who have sold in hopes of buying it back cheaper. Since shorts have little choice but to buy when a stock moves, their demand, added to the new demand from longs who want the stock, pushes a stock up quickly in a short period of time. A move of 10–15% or more is not unusual in such cases.

The longer cycles build upon the short-swing trading cycles as market price moves upward and releases funds from previously frozen forcebands within the field. Volume



can now flow from the forcebands since those who bought at a higher price are enabled to liquidate their position, and—since they are generally disillusioned with the stock that froze their funds—are in a position to move into a new situation. If price continues upward, more and more of these frozen positions will become liquid as more and more forcebands are touched by the new price swing.

The longer cycles build, then, from the combination of trading money, from the newly liquefied old positions and from new money attracted by price movement. Since there are relatively few traders who become frozen into positions for more than a short while—if they did, they would soon lose their trading capital and their identity as traders—most of the money released by the movement of price is longer-term money and new money which is interested in longer-term gains. As a stock moves upward, the new higher prices attract more and more long-term buyers, and the farther price travels, the more buyers it attracts. Also a factor is the continued buying of previous buyers for whom the stock has performed well.

From this view, it is possible to postulate that volume is what accounts for the amplitude of a stock's movement. The attraction of a consistent and upward price movement continually attracts more long-term buyers with cash—but, remember, it is buying volume which pushes price up and price which attracts the volume.

Eventually, some of the early buyers and some of the long-term buyers will become afraid of a reaction and begin selling—or refrain from further purchases—and, when enough of them have quit buying or started selling, the movement will reverse polarity and direction—because buyers have reversed from the positive polarity of buying to the negative polarity of selling.

We can see, then, that cyclical movement is really a function of the price-volume relationship, and that the longer cycles are reflecting a continuing volume of demand for stock while the shorter cycles are reflecting an alternating pattern of buying and selling. That is, the short cycles move up fast on “instant” demand and down fast on “instant” supply caused by the movement of price. The long cycles move up more slowly on long-term demand, so it is largely the psychology of the buyers which determines cycle length. The amplitude of each cycle, however, is a function of volume or the quantity of stock crystallized into transactions by decisions. Taxes, of course, have a lot to do with investment psychology since they make long-term gains more valuable than short-term profits. A lot of decisions, too—or perhaps nondecisions—are based not on the psychology of the owner but on the psychology of his wife. How much hell will she raise if he takes home a loss?

In a bull market, the seller is more important than the buyer

Another factor that we have to keep in mind about volume is that, in a bull market, the seller is really more important than the buyer, which is the opposite of what most of us would expect, and which, of course, is not to deprecate the role of the buyer in the market. (In a bear market, the roles reverse and the buyer becomes more important.)

As we saw in our simile of the electric battery, the flow of electrons through a circuit connecting two poles of a battery is from negative to positive. In a bull market,



stock flows from seller to buyer, since the seller is the one with the problem. The buying is easy—a buyer has an option: to buy or not to buy—but the selling is hard.

The reason the seller is the principal factor is that the only way you can make money in the market is to sell the stock you bought at a profit. Don't sell and your profit is only paper and may disappear. Sell lower than you bought and you lock in a loss. The seller thus has the problem since he must dispose of his stock profitably if he is to profit for his time, money and effort. Stock, therefore, flows from seller to buyer on the way up. You don't buy stock, you take it away from a seller who ranges from eager to downright unfriendly.

So, since it seems that the sell side of a bull market is always the more significant force, it also appears that the market goes up because there are fewer sellers (in relation to buyers) than previously, and it goes down because there are more sellers than previously. (See Fig. 3.7.) This is the reason that increasing volume in a bull market is bullish for prices most of the time because increasing volume, purely and simply, means more buyers in an upward market. There is always a quantity of stock to be sold at any price level, but, as we said earlier, when prices are rising the quantity of stock for sale decreases just when demand for the stock is increasing, since who wants to sell lower than necessary?

When a peak is reached, however, stock to be sold comes to market in increasing quantities as previous buyers become sellers. The largest distribution of stock from "strong" hands to "weak" ones occurs after the market has peaked. If a seller can't get a high price, he can still get out at a profit all the way down to his buypoint. As prices approach old buypoints, more and more stock comes to market to be sold.

Eventually prices subside below the various buypoints, and then volume begins to dry up, since the sellers do not want a loss unless it appears quite strongly that their loss is going to get bigger and bigger. Like a lot of other problems, losses in the market either go away, if you leave them alone, or get big enough to devour you. Since there is always hope that the problem will dissolve, most people let their losses stand and await developments—so, as losses mount and price drops, the supply of selling volume is decreasing. Since prices are dropping, buyers are also disappearing. The eager ones have bought at the top; those less eager have bought on the way down; the less astute have doubled-up their positions earlier and the more timorous simply slip away. As prices decline, the number of would-be buyers diminishes, the number of would-be sellers gets smaller—and volume diminishes.

In some markets (repeat, some), the holders of stock eventually lose all hope. When this happens, volume rises spectacularly as more and more stock comes to market. The sellers can no longer hope to recover their losses and finally want to get out before prices decline further. They dump their stock on the market at ridiculous prices, since the abandonment of hope of at least getting even means that the stubborn holder has lost his perpetual optimism and changed from one who waits for prices to rise to one who is willing to salvage any cash he can get.

This brings up an aside worth inserting here. Consistent "losers" in the market are those who are more concerned with "getting even" than with winning. The reasons they are always playing "catch-up" are: (1) they failed to recognize their original



mistake in buying a stock, and, as it continues to decline, substitute hope for reason and (2) they lose more because they “can’t afford” to lose less. A mistake is a mistake, and allowing one to grow (or worse, compound) is the worst thing you can do when market cycles are going against your position.

How and why support and resistance forcebands form in the cyclical field

The cyclical field model which we have presented was designed for the purpose of explaining the relationship between price and volume and the effect this basal relationship has on the market and on individual stocks. That is, the market is really a circus at all times. One thing is going on in ring (cycle) 1, another in ring 2 and still another in ring 3, to say nothing of what is going on around the edges—all at the same time. The important things to learn in the market are: (1) what is important and (2) how and why the market operates as it does. When you know how and why something is operating, (1) your fear declines, (2) you can estimate the probabilities of it continuing and (3) you can make plans to utilize your knowledge.

In the model, we pointed out that the forcebands which form in the cyclical field are harmonic values which form largely from the “iron filings” of previous transactions. That is, the forcebands of the field are zones at which previous transactions have occurred, when the market is plowing old ground and at likely harmonic areas when the market is in new ground. Perhaps the easiest way to understand this is through the explanation of the technical analysts, who label them support and resistance lines.

Basically, “support” arises from would-be buyers who lost their first opportunity to purchase a stock at what they consider a reasonable price, only to watch it move considerably higher. They associate the price at which they missed their purchase with a bargain level, and (when the stock reapproaches that price) their eagerness to buy is indicated by the buy orders which pile up on specialists’ books at certain levels of price. When a stock is declining, it eventually reaches a point at which there are buyers standing in line at harmonic levels of association between price and “value.” This buying provides “support” against further declines and is, as the technicians know, a very valid point on a chart at which price can be expected to turn, or at least, hesitate in any future decline.

“Resistance” is the exact opposite of support. Lines of resistance are also harmonic with prices at which previous transactions have taken place, but this time they are harmonic with would-be sellers’ ideas instead of buyers’. That is, when a person has bought a stock at a low price, seen it run up to a high price and then watched it retreat (with the cycles, we must add), he resolves to sell on the next approach to his would-be sale price. The “profit” lost between buypoint and sellpoint is recoverable if the stock again moves up. As a result, sell orders will accumulate at or near previous high prices, and, also, as technicians know, this can be very effective in halting an upward movement of the price of a stock.

Now we pointed out, when the market is in old ground, that support and resistance lines form at harmonic price levels at which previous transactions have taken place. What we are saying, basically, is that these lines are really volume accumulations at specific prices, and, since price stayed in the area of the lines while there was lots of



tick-rhythm volume, it is really not price which is important but the amount of volume which accumulated at these points.

This gives us a clue to the idea that if we count the volume which occurred at previous support and resistance lines, we can get a good estimate of how much volume will be required for a stock to move through these lines. It is not as simple as that, however, since, as we pointed out earlier, the quantity of stock at a specific price changes when would-be sellers and would-be buyers cancel their orders as the situation changes. However, since the technicians, who operate mostly empirically or visually, find these lines to be of value, we can assume for now that they are valid assumptions.

Support and resistance bands and triangles are really volume accumulations at harmonic levels

When the market is in new ground, support and resistance levels also will form in the new ground. These formations, too, will be the result of association of price and “value.” That is, “value”—which is really nonexistent in the market—and price, get mixed up in people’s thinking, regardless of how high price may be. A lot of it is the magnetism of the striking zone of the cyclical field, and a lot of it is because people fail to see the price scale on the side of the chart or, if they haven’t been paying attention, don’t know why the price scale is there. At any rate, when stocks move up beyond previous highs, we know that volume will accumulate at specific price levels in the future, just as they have in the past. How do we know?

The answer is cyclical. Cycles are powered by the force of volume—operating against a radius of cyclical price—which causes a cycle to revolve and carry the background of price up or down in relation to the striking zone. Since this movement is cyclical, we know that a point will be reached when the cycle will alternate, and we also know that the reversal of direction will come at the top of a cyclical swing.

Since it is the delusive attraction of price that causes cycles, it is also the quantity of volume (moths) which is attracted by the movement (flame) that causes the pileup of volume at the support and resistance lines technicians find in stock charts. New cyclical peaks, therefore, always leave behind a quantity of people who bought at the top of the swing and at harmonic levels within the swing.

In this regard, another very valid technical observation is that triangles form at certain levels. Triangles represent the swing of price at ever higher peaks and lower troughs in an expanding triangle, or, in the case of diminishing triangles, at ever lesser peaks and troughs. For instance, in Fig. 1.13, we can see that the peak of the market in 1929 came about because of the thrust of price from the expanding triangle which formed in the first half of 1929. (This triangle, incidentally, gave birth to the phrase “expanding top,” which has ominous connotations. Expanding triangles, actually, are lovely affairs from which a thrust nearly always doubles the final leg.) The same sort of action occurred at the 1961 high, as seen in Fig. 1.12, when the expanding triangle which concluded in the final 1960 quarter thrust prices up from about 570 to about 700, at which point another (and this a failure) triangle finally marked the peak of the 4.25-year cycle.

Now look again at Fig. 1.13. We see that the triangle centered at about 310 DJI,



and in Fig. 1.11 we see that the market in 1951–52–53 had a hard time breaching the line of resistance set by the 1929 triangle. Likewise, we can see in Fig. 1.12 that the expanding triangle of 1959–60 centered at about 650, that the first trough of the triangle stopped at about 630 and that this price level (630) caused the final upswing of the triangle (point 3 to 4) to fail to exceed the previous peak (point 2). In mid-1970, as we know, the market decline also stopped at about 630 DJI. The would-be buyers from 1959–60 who “missed” the rise of the Dow to 1000 in 1966 and again in 1968 (and those who sold out somewhere along the line) got another chance in 1970. That’s the nice thing about cycles—for every upthrust there will be an equal and opposite reaction, and from the reaction trough another upthrust. Don’t you believe in cycles yet?

How volume has acted from the beginning of the DJI

Normally, instead of accumulating, volume simply declines as price declines and rises as price rises. Rising prices and hopes of a large profit bring would-be buyers to market, and falling prices and fears of a large loss keep would-be buyers away from the market.

For instance, in Figs. 2.2, 2.3, 2.4 and 2.5, we illustrate the movement of the Dow average from the beginning in 1897 through the end of 1966 on a monthly basis. At the bottom of each chart, the dotted line is a 12-month moving total of volume, made by adding the first 12 monthly figures and then sequentially adding the next month and dropping the first month of the series. Before we look at the charts, however, we need to know something about a moving total. It tends to carry beyond a peak and to be slow in pointing out a bottom, since at all times it carries all 12 months in the total.

This is especially true of moving volume totals, since there is a buildup to a peak of volume and quite often a large decrease after a peak, because the peaking area of the moving total includes not only buying volume but a large dose of selling volume as well. For instance, in Fig. 2.2, the moving total indicates that the peak of volume came in October 1901. Instead, the top volume month of 1901 was April, with a total of 41,719,000 shares for the month, and this was closely followed by May with a monthly total of 35,292,000 shares, or a daily average of 1.41 million. The moving total continued to climb after the actual peak, however, because the takeaway numbers for the same months of 1900 were considerably less than those in 1901, despite the peak in April.

With the knowledge that a moving total, as we use it—plotting the figure at the end of the series instead of at the center of the span—can carry beyond the peaks and troughs as they actually occurred, we can see from the charts that when volume was rising, the DJI was rising. For instance, in 1898–9, the volume total went from about 80 million shares in 12 months to a high of nearly 180 million shares at the end of 1899. The DJI accommodated the buying with a rise from 42 to 78—a rise of 225% for volume and 186% for the DJI.

In the next surge of volume, in 1904–06, volume rose from about 120 to over 300 million in the period, a rise of about 250%, while the Dow rose from 42 to 103



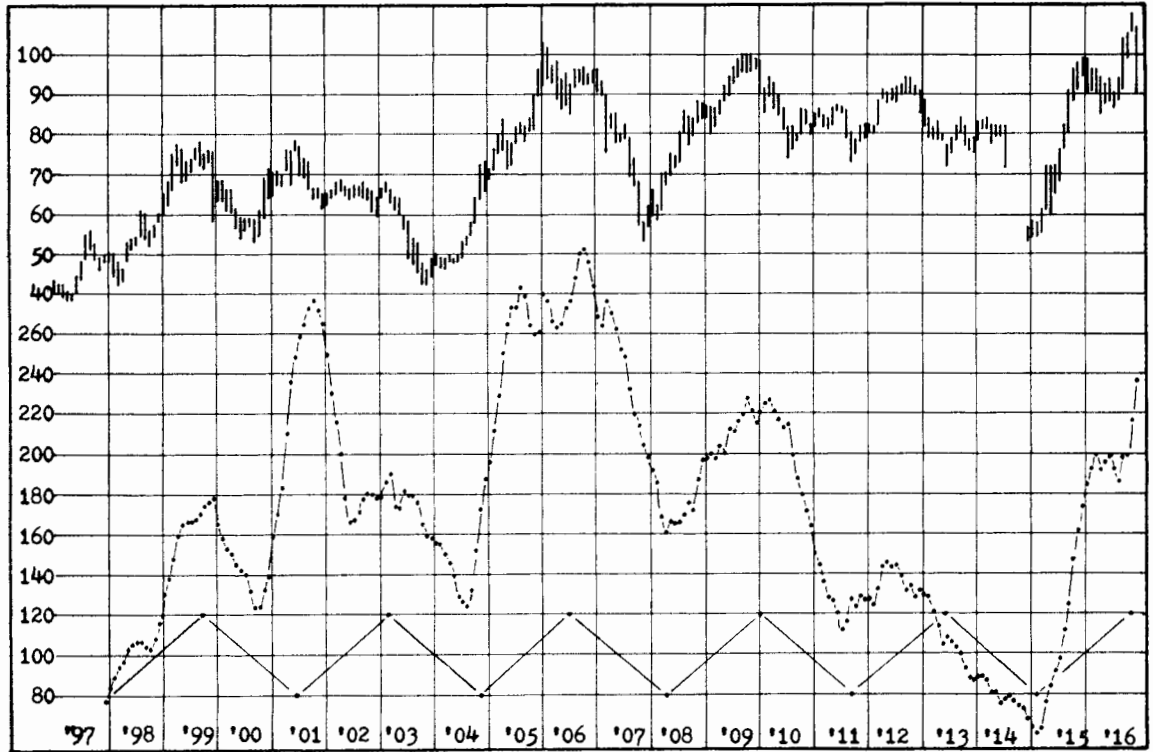

Fig. 2.2—The Dow industrial average and a 12-month moving total of NYSE volume, 1897–1916.

or 245%. In 1906–08, when the Dow declined from 103 to 53, or about 48%, the volume totals declined from 300 million to 160 or 47%.

In Figure 2.3, it can be seen that the 595% increase in the DJI, from 64 to 381 in 1929, was accompanied by a 534% increase in the volume total, from 220 million to 1175 million shares per year. In the drop from the 381 DJI closing peak in 1929, the Dow declined 9.29 times and the volume declined 3.25 times. Volume, as we can see, declined while the Dow was declining and rose while the DJI was rising. We can also see that there was a difference of about 160 million shares from the volume low in 1924 to the 1933 low, 380 million vs. 220 million. Somewhere along the line, those 160 million shares never came back to market until well after the boom and bust. Volume on a moving total basis never came back to its 1924 level of about 220 until 1935, and then mostly continued downward until 1942. Buyers are scarce in depression and war.

The same sort of relationship of price and volume continued in effect through the Depression years and on to the postwar year of 1949, shown in Fig. 2.4. When volume rose, the DJI rose, and when volume declined, the DJI declined. During the war years, from the April 1942 low of 94, the DJI climbed to a 1946 high of 206, a 219%



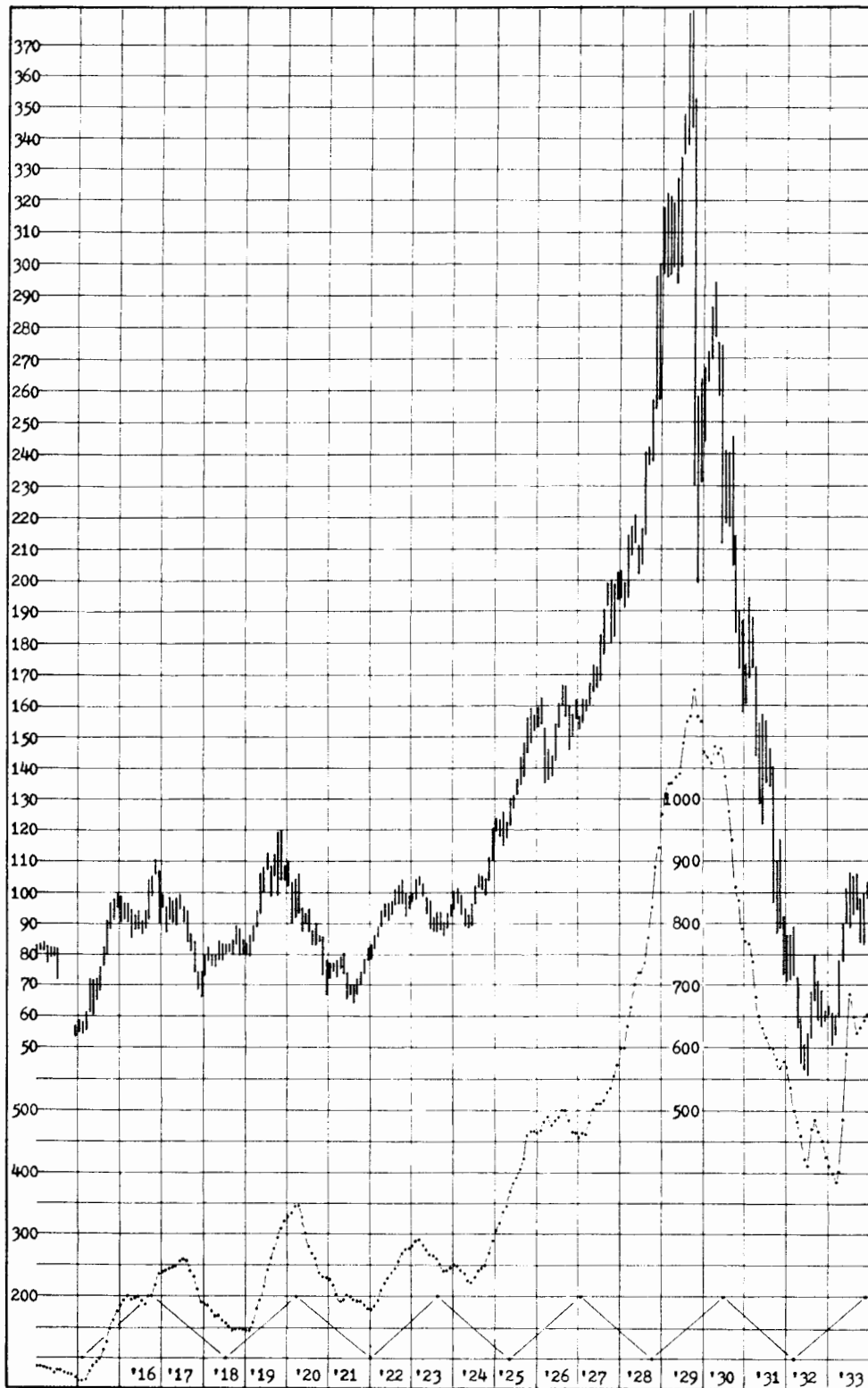

Fig. 2.3—The Dow industrial average and a 12-month moving total of NYSE volume, 1914–33.



increase. Volume during the period rose from a 120-million share total to about 400 million shares, a 333% increase. Prices were not as volatile as at other periods (people were selling stock), and the 1-to-1 relationship of price and volume was “heavy” on the volume side.

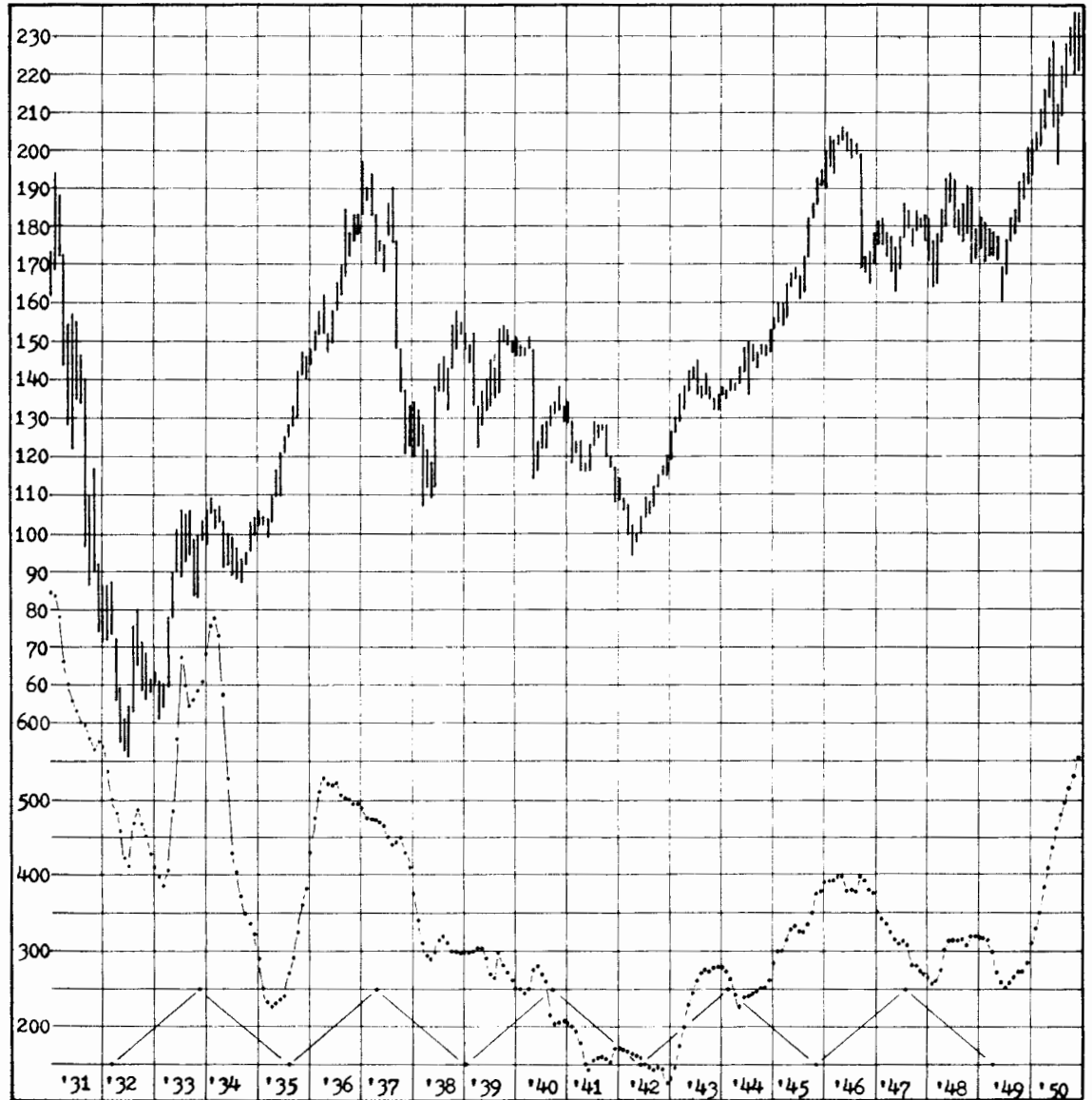

Fig. 2.4—The Dow industrial average and a 12-month moving total of NYSE volume, 1931–50.

In Fig. 2.5, we see that the 625% increase in the price of the DJI from the 1949 low to the 1966 high was accompanied by an 800% increase in the volume curve, from

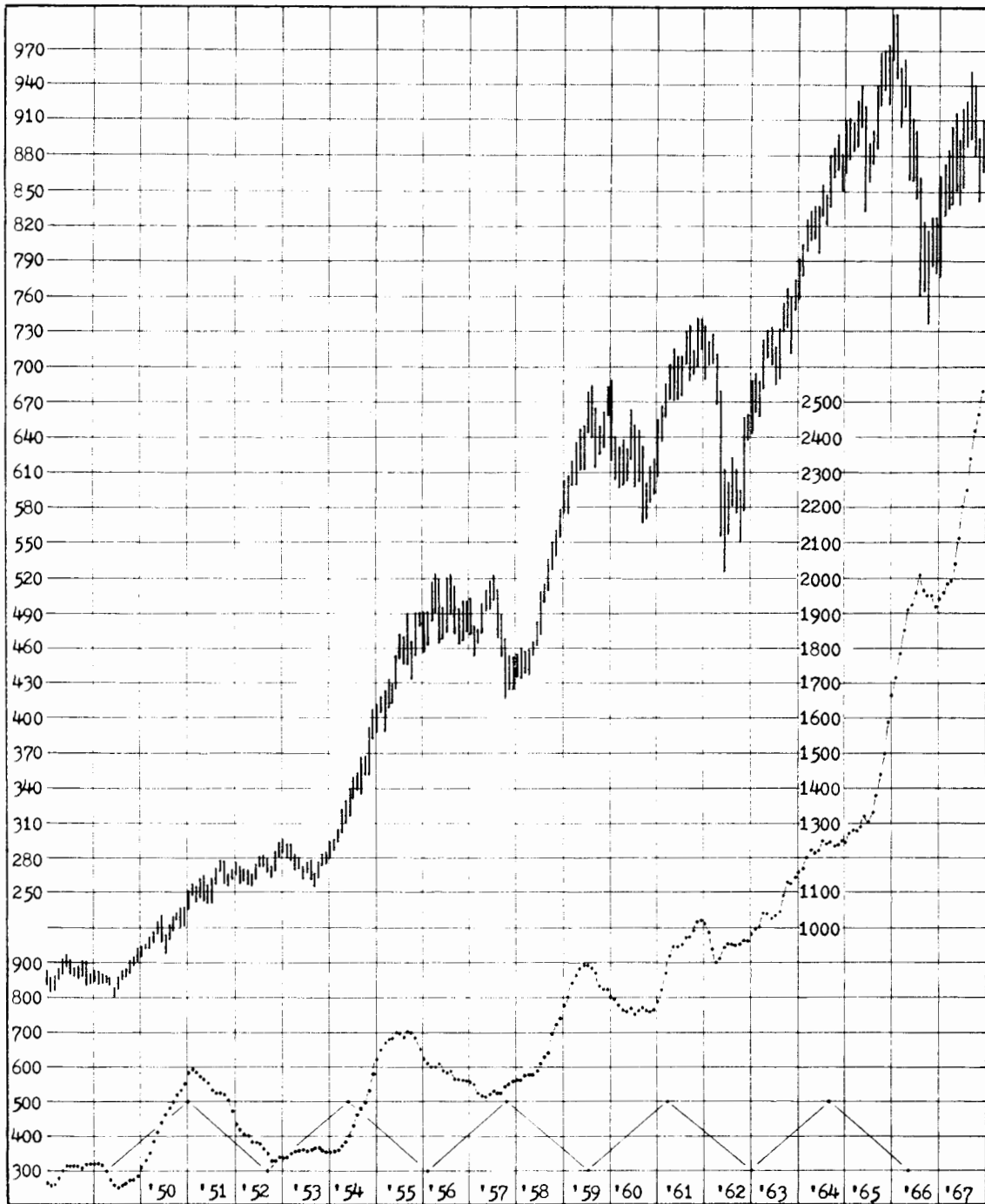

Fig. 2.5—The Dow industrial average and a 12-month moving total of NYSE volume, 1948–67.

a 250-million total to the 2-billion total at the peak in 1967. In other words, all during the 1949–66 market rise, buyers came into the picture almost continuously. This time, the price side of the teeter-totter was “heavy.”

How moving volume totals reveal long and short cycles

At the very bottom of Figs. 2.2–2.5, we have inserted a mechanical or “ideal” $3\frac{1}{2}$ -year cycle which shows up particularly strong in the years prior to World War I and for about three revolutions after the war, prior to the beginning of the 1929 rise. This cycle has allegedly been present in economic affairs for many years, since the date of the first allegations were about 1923. As we can see, however, since 1935 this cycle has largely disappeared, showing up on “ideal” schedule only in the 1935–38 markets and again in 1949–52. As in the 1929 rise, it was largely nonexistent in the strong upward markets from the 1953 bottom.

If we note that when the outlook is good cycles tend to move to longer lengths and when the outlook is short the short cycles tend to take over, we can see that before 1932 volume and the short cycles were fairly closely coordinated. We can also see, in Fig. 2.2, that, allowing for the carryover of the moving total, the 4.25-year cycle also showed a tendency to be present in the volume figures. The actual low-volume month in the latter half of 1903 was September and the low-volume month in the first half of 1908 was February—a period of four years and five months. We also must note that a 3.5-year cycle is just 43 weeks short of the length of the 4.25-year cycle, providing the 3.5-year measurement is accurate—or that the difference could actually be two revolutions of the 25-week cycle.

When we look closely at the accompanying volume charts, we see that the 68-year history of the Dow industrials breaks nicely into four versions of the 17-year cycle. We can also see that the moving total of volume is superior to prices as a means of measuring cycle lengths. For instance, in the first cycle from 1898 to 1915, volume went from 80 million shares per year to a high of 300 million in 1906—or eight years from the beginning—and then subsided to about the opening total in early 1915. As far as volume was concerned, this was a near-perfect cycle of 17 years, since it rose to a peak near the center of the length and subsided evenly to the next trough.

With the intervening war, the second version showed little gain at the center in 1924, but the second half of the cycle—the $8\frac{1}{2}$ -year cycle—performed about the way we would expect a cycle to operate. Volume increased from 1924 to 1929 and then subsided to a low in 1933.

World War II had an effect on the 1932–49 version of the 17-year cycle. As a result, this cycle also broke down into two periods of about $8\frac{1}{2}$ years. Volume, with minor exceptions, decreased from 1932 to mid-1941. The second version of the $8\frac{1}{2}$ -year cycle reverted closer to an “ideal” performance, starting up from the 1941 low, peaking in 1946 and decreasing to mid-1949.

The post-World War II version of the cycle, as the volume curve reveals, also broke into two $8\frac{1}{2}$ -year cycles, divided by the 1957 low. The first portion further was broken into two $4\frac{1}{4}$ -year cycles, from 1949–53 and from 1953–57, as was the second portion, which marked the low by a hesitation in the rise of volume in 1962



and similarly at the 1966 lows. Thereafter, volume continued upward at a faster and faster rate as the forces of inflation came on stronger and stronger.

From reviewing the charts, then, we can see that volume and price both tend to form into cycles of varying length, depending upon the economic climate.

Volume plays on the market's harmonic cyclical structure

Daily charts provide a short-term picture of market action. Weekly and monthly charts provide a longer view, but to get a single, long-term, overall view of the whole market since the early 1900s we need to see a quarterly chart. Such a one is Fig. 2.6, which shows a 65-year span of the Dow industrial average, and at the bottom the actual (unaveraged) quarterly volume on the New York exchange. The movement of the Dow—and also the volume—is calibrated in this arithmetic chart from zero to 1000 in sixteenths—or about the same harmonic values we first saw in the piano-string example in Chapter 1. It is to be noted that the same scale—zero to 1000 in sixteenths—is used for both parts of the chart. On the volume scale, which rises only to 500, the second half of the scale is shown in the price scale, from zero to 500, so that the two halves equal the whole of the price scale.

The first thing which greets our eyes in this chart is that there is a remarkable correlation between the price of the Dow average and the quantity of volume. Since the two are identical scales, we can see that the 1-to-1 relationship of price to volume, although a variable, is an historic fact. That is, over a 65-year sweep of the market, price movement of the Dow and volume quantity have been expressible, for the most part, as a 1-to-1 relationship.

Since we know, from the piano-string example, that the scale of the chart is in harmonic values, we can see that the 65-year movements of the Dow have also been harmonic. That is, until 1924, the Dow was mostly confined to a one-octave movement between 62.5 and 125. Volume oscillated in a lesser octave, between nearly zero in 1914 and 62.5—or 62½ million shares traded per quarter. Both price and volume moved into the next octave in the late 1920s, and the Dow subsided shortly after it penetrated the 375 level in the center of Octave IV. Volume, still on a low key, moved to 300 million shares. After the 1932 correction, and until 1950, price was largely playing in Octave III of the chart—between 125–200—while volume moved up to the second octave, between 62–125.

In 1951, the Dow moved into the 250–500 octave (IV), the bottom of which gave good support in the sideways move to 1953, and then continued up until it ran into the resistance provided by the bottom of the next higher octave (V) around 500. In the highest octave (V) of the chart, we note from the scale that in addition to the eight parts of this octave, we have drawn in lines which represent the values of “F” and “A” in the musical scale. Prices fluctuated back and forth around the “F” note area for four years, from 1959 through 1962, and then moved up to 1000 in early 1966. Since then, as we can see, the “A” area of the chart has been the center for successive fluctuations.

Now, since the Dow average over the years has demonstrated a tendency to form support and resistance bands at harmonic intervals in its travel up to 1000, let us

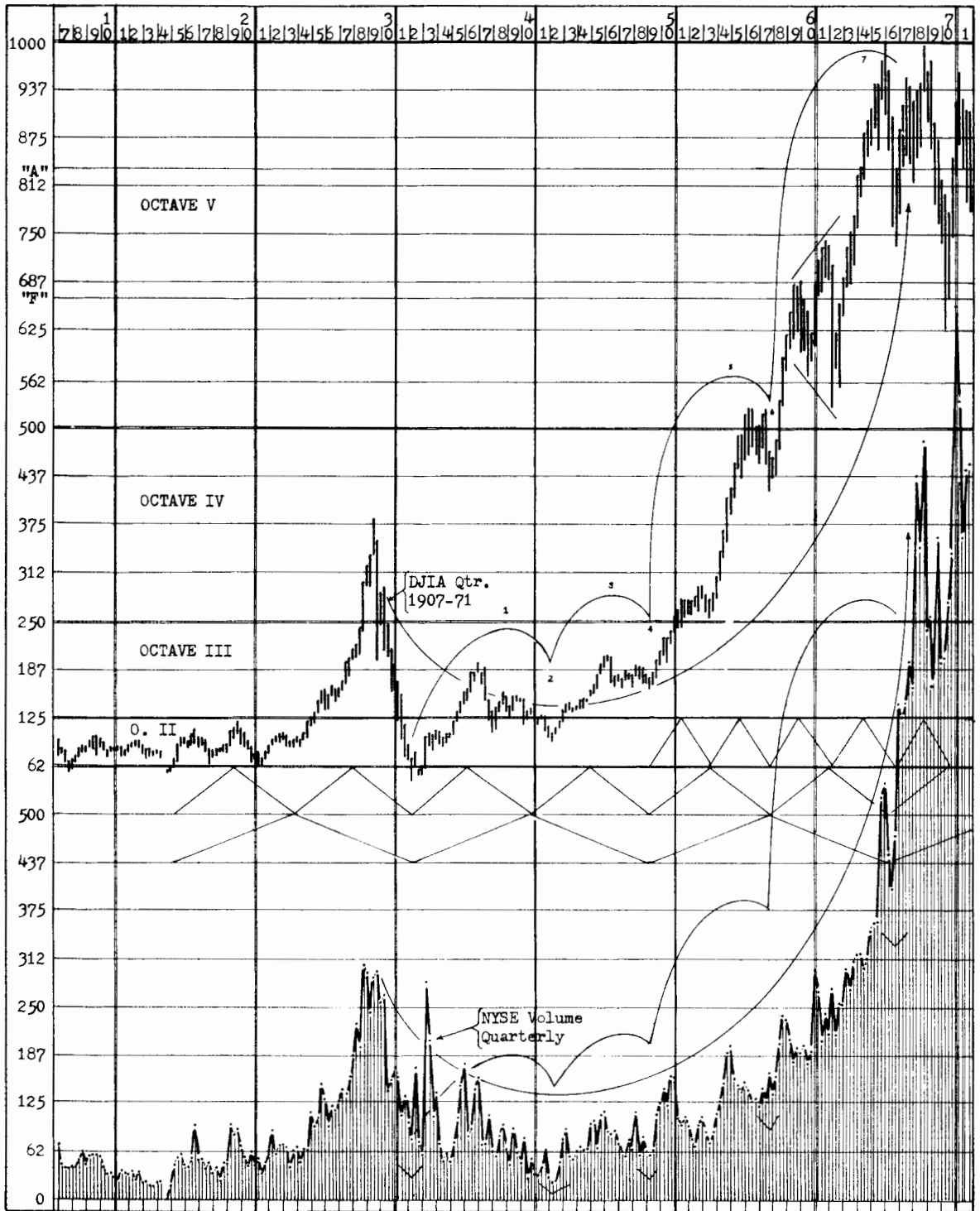

Fig. 2.6—Quarterly-basis history of the Dow industrial average and NYSE volume, 1907-71.

assume that our hypothetical cyclical field model is a genuine expression of the market's cyclical framework. That is, the forcebands of the market which fan outward from the striking zone seem to form at harmonic numbers in the field, and, as the facade of price moves up and down behind the field, the magnetic forcebands cause the movement to halt near harmonic values.

It is relatively easy, in this chart, to visualize a stationary cyclical field as a framework for the observed movement of price. That is, until 1950, the Dow average moved only slightly, in comparison with the last part of the chart, so that only small movements of the price backdrop were needed. Also, in this period, price and value were constantly reassociated, since price always returned to what apparently was value levels of the time at about 62 DJI. The movement of price in that period was mostly associated with the harmonics of a single cyclical field frame with limits of about 62.5 and 125 DJI.

During World War II, however, the price of the Dow average moved away from the 62 base and did not return. Each succeeding swing of the Dow troughed at higher levels than previously, as the backdrop of price—forsaking the 62 DJI value base—appeared in higher and higher numbers.

Now we notice that, as we progress upward, each harmonic octave gets larger and each top value is twice the lower value. Each octave is basically the same except that each higher octave has (1) bigger numbers on the price scale and (2) twice as many divisions as the previous octave. Now, if we assume that each octave comprises a single view through the cyclical framework, we can see that there have been three major shifts of the price backdrop since 1915 and that they also break nicely into three larger parts: (1) from 1915 to 1932, (2) from 1932 to 1949 and (3) from 1949 to 1966. Also we can see that each of the cyclical swings, each in its own octave, is largely a repetition, on a larger scale, of those previous. That is, each swing of the 8½-year cycle was distinguished by (1) an upward surge, (2) a hesitation, (3) a final thrust and (4) the trough. Further, the disagreements with this pattern are largely a matter of degree. Volume, we also can see, largely moved concurrently with price. For now, then, we can assume that the harmonics of the field—its framework—remain constant and stationary; price changes are the result of the movement of the price backdrop behind the cyclical frame, so each movement is framed by the same harmonic values.

From the chart, we can see that there are three major cycles which operated over the 65-year period: the 17-year cycle; its half brother, the 8½-year cycle and its little brother the 4¼-year cycle, which has only been obvious since 1949. The choice of quarterly units for the chart, of course, eliminated most of the effect of smaller cycles. Since these three are harmonic cycles, they work together, and the movement of price of the Dow is the sum of the movement of all the cyclical values. Consequently, we can see in the Dow the swing of each cycle and, also, the combined effect of all three cycles.

With our assumption of a constant frame, the harmonics of the cyclical field, in conjunction with volume flow, allow us to estimate the extent of cyclical swing in the future. That is, by knowing the framework of the market structure and estimating the amount of volume flow, we can arrive at a reasonable guess about the future.



provided our guess is based on cyclical rhythm. We wouldn't have been too far wrong, for instance, if we had guessed in 1940 that the next trough of the 8½-year cycle would have appeared around 1949. and, as volume came more heavily into the picture and facilitated cyclical movement, our succeeding guesses would have been closer and closer to the mark, with troughs appearing in 1957 and again in 1966—and, probably, in 1974, etc. Also, we could have estimated accurately the 1966 trough of the 17-year cycle and, in between, the troughs of each of the 4¼-year cycles. Each longer cycle, thus, asserts its dominance over other smaller cycles, principally when it is in a troughing phase.

Now since each succeeding trough from 1942 to 1966 came at higher and higher price levels than the preceding trough—and since the higher price levels are closely connected with volume levels—we see that any projection of future price levels must include an estimate of future volume levels. That is, cyclical swings are not of price alone but also derive from volume, since it is volume which powers the cyclical price movement, just as it is the bow which makes a violin sing.

Elliott fans may be interested in the curves on top of the Dow track in the figure. From the 1932 low, the count to the 1966 peak is four major moves and three minor moves for a total of seven. That is, from the 1932 low there were four major impulse moves and three major recoils. The 1959–62 swing of the 4¼-year cycle was not a major move but a correcting triangle—or a “protracted trend hesitation” in Elliott's * words—just as were the hesitations in 1951–53 and in 1943–44.

II—The Invisible Mechanism of Cycles

The word *cycles*, derived from the Greek word *kyklos*, whose meaning is ring or circle, basically implies two things: (1) A specific event has occurred at a sufficient number of sufficiently regular intervals to be observed and (2) in light of its history, it is most likely to continue recurring at regular intervals in the future. But there is also another implication in the definition: The recurring event results from a buildup of tertiary forces which are extra-systemic, or outside the continuous functioning of the forces within the system.

That is, a cycle is noticeable because it is exceptional to the assumed regularity of a system, and, also, because the deviation occurs at regular intervals. The earth travels a regular course around the sun, but it is not the travel which is exceptional, since that is constant, but the annual phases which, in our eyes, mark the continuing travel. For instance, because of the steady progression of winter, spring, summer and fall as the earth follows its orbit, we always expect snow in winter and flowers in summer.

This regularity of natural cycles implies (1) there is a mechanism or system which underlies the observed events and (2) as astronomers have with planetary

* From R. N. Elliott, “The Wave Principle,” as published in a series of 12 articles in 1939 in *Financial World* (17 Battery Place, N.Y. 10004). By permission.



movements, the secret of when to expect a recurrence lies in the discovery and understanding of the underlying system.

To begin our search for the cycle mechanism, let us first examine what we have learned thus far: (1) cycles move (2) along an axis and (3) their basic shape is circular. According to Newton's laws, (1) their movement must be the result of a force or thrust and (2) to balance the thrust, there must be an equal and opposite reaction. We have already seen that a cycle, like a year, has four seasons: (1) the thrust, (2) the slowing of the thrust, (3) the recoil or reaction against the thrust and (4) the slowing of the recoil.

In addition, we have learned that most stock flows from the cyclical field which forms when stock passes through the striking zone of a central market. In the field are the forcebands of volume which accumulate at harmonic price intervals throughout the field and form support and resistance zones in the field for both individual stocks and a market average. At the outset, then, we realize (1) that cycles must derive from an underlying system which provides a constant flow of stock through a market and (2) that, since cycles are regular and orderly in their rhythms, they must be controlled by a second system of influence.

A cycle moves because of a thrust against its own circumference

Near the small end of infinity, and visible to most of us under the microscopes of our high school science courses, was a one-celled animal called the paramecium. While this creature is more refined than basic cycles, it demonstrates a principle which is essential to the understanding of the cyclical system: The paramecium moves by thrusts against its own circumference.

If we consider that a cycle is circular, we can see that a thrust from within the circumference would result in the circle changing its circular shape and becoming parabolic or egg-shaped, and that the extent of change in the shape would largely be the result of the quantity of force expended.

From Newton's laws, we know that for every force there is also an equal and opposing reaction which exactly equals the thrusting force. Ordinarily, then, we would expect that a circle would simply revert to its circular shape from any distortion caused by a thrust, but—if the thrusting force were strong enough to move the axis of the circle, as well as alter the circumference—a recoil from the thrust would not return the circle to its original position. (A chicken hatching from an egg is a good simile.) That is, a recoil from a thrust which was strong enough to move the center or axis of a circle could not move the circle back to its original position—because a recoil's primary function is simply to return to a balance with a force, not to neutralize the thrust of the force entirely.

Let us assume that a thrusting force increases from a 1-to-1 balance with the recoiling force and goes to a 2-to-1 ratio. This amount of force would be sufficient to move the axis of a circle and the axis would remain beyond its original point, because, as the thrust subsided and the recoil gained in strength, a part of the force of the recoil would be expended in reverting to the original circular shape. Unless the



recoil went to a full 2-to-1 reversal of its ratio with the thrust, the axis of the circle would remain at about half the distance it was carried by the thrust and the recoil would seek balance at the new location.

The paramecium and the cycle, then, move by the amount of excess thrust over the 1-to-1 balance of the completed recoil. A caterpillar moves in much the same manner, with the front end thrusting forward and the rear end being dragged up behind, so that when the rear end is in place, the caterpillar is again in its original balance—ready for another thrust. Besides allowing for movement, this arrangement of a thrust and a counterbalance of force is also a basic principle of growth: Growth results from a thrust and a recoil since the net movement of a radius point along an axis also results in an enlargement of the basic circle.

The characteristics and properties of the Fibonacci series

In the 12th century A.D., an Italian mathematician named Leonardo da Pisa, or more likely Leonardo Bigollo Fibonacci (from Pisa)*, travelled to the Middle East and was introduced to a mysterious set of numbers which he brought back to the western world and which now bear his name—the Fibonacci series.

The series is produced by adding any two adjacent numbers to arrive at the next higher number, or subtracting to arrive at the next lower number. Starting with 1, the series is: 1, 1, 2, 3, 5, 8, 13, 21, 34, 55, 89, 144, 233, 377, 610, 987, etc., to infinity.

After the smaller numbers, each of the Fibonacci is related to the next higher number by the ratio of 1-to-1.618 and to the next lower number by a ratio of 0.618-to-1. If you divide 987 by 610, the answer is 1.6180327, and if you divide 144 by 89, the answer is 1.6179775. If you divide 34 by 55, the answer is 0.6181818 and, if you divide 21 by 34, the answer is 0.6176470. The Fibonacci, thus, are not an exact ratio, like pi, but lie on either side of the 1.6180 and 0.6180 axes. That is, one number is related to another number by, first, slightly more than and, second, slightly less than 1.6180 and 0.6180 until the largest numbers are reached. The relationship, however, is accurate to the third decimal, which is usually more than adequate.

In addition to the 0.6180 and 1.6180 relationships, there are others: Between each third number of the series there is a further upward relationship of 2.618 (144:55 = 2.6181818). Besides this, 1.618 squared equals 2.618 (2.617924) and the reciprocal (1 divided by 1.618) equals 0.6180469.

The Fibonacci (1.618) is also referred to as phi. Since it lies just above one-half pi (1.5708), it is closely associated with pi, which is the sixteenth letter of the Greek alphabet. Phi (ϕ), the 21st letter of the alphabet, is a combination of one-half the capital symbol of pi (II) and omicron (o), the 15th letter of the alphabet.

Despite, or perhaps because of, all the mysterious mathematical relationships, the Fibonacci series has never until recently been regarded as much more than a curiosity by scholars. Fibonacci himself seems to have used the series principally to explain a

* See page 94.



progression of numbers, such as the multiplication of rabbits from a single pair. There is much more to the series than can be lightly explained away, however.

For instance, besides its mathematical properties, the series carries over into natural and man-made objects and living plants and animals. In a pine cone, the “grid” of opposing swirls which can be observed is composed of five lines in one direction and eight in another. The ratio of opposing swirls in a pineapple husk is 8:13, in a daisy head 21:34 and in a sunflower head 34:55. Besides these simple ratios, there are more complicated mathematical arrangements in nature such as the logarithmic or equiangular spirals in sea shells, elephant tusks and the horns of the Rocky Mountain goat. In addition, the relationship is to be found in such things as the Golden Rectangle of art and architecture (it appears in the works of such painters as da Vinci and in the shape of the Parthenon in Athens), and even in the properties of the 4000-or-more years old Great Pyramid of Egypt.

The trigonometry of a square and a rectangle

Before we go further in our search for the system which controls cycles, we need to look again at Fig. 2.1. First, on the left of the vertical axis are a series of seven arrows which indicate, by running from the axis to the circumference of the circle involved, the length of the radius. As each radius moves up the vertical scale, its length increases, because each radius length is established by the distance from the new axis position to the corner of the square in the striking zone. That is, the radius of circle 1 runs from the center of the striking zone to its circumference which encloses the striking zone square. The radius of circle 7 runs from axis 7, and its length is determined by the distance from axis 7 to the lower left corner of the basic square.

Second, on the right side of the axis, we have drawn in rays which divide the quadrant into eighths by intersecting with the corners of the grid of squares which overlies the field. That is the first ray, which terminates at the top and has an angle of $75^{\circ}58'$ from horizontal, intersects the corner of a 4-to-1 rectangle. The second ray has a grid relationship of 4-to-2, etc. Below the angle designations in the illustration are tangent and sine values for the angles involved.

The relationships which are apparent from the grid are the tangent values of the rays. The tangent value of 4.00 indicates that there is a 4-to-1 relationship of the squares in the grid. The same is true of the other relationships, all of which intersect at a corner of the small square in the 4-by-4 square of the large grid.

The sine relationships, however, are a little more difficult to understand. One difference between sine and tangent arises because the sine value fluctuates from zero at horizontal to 1.00 at vertical, while the tangent value fluctuates from zero to infinity in the same 90° arc of a circle. The sine value is the relationship between the length of the vertical side (in these triangles) and the length of the hypotenuse. The tangent value is the relationship between the horizontal and vertical sides of the triangle so that at 45° , as we can see, the two sides of the triangle have a 1-to-1 (or 4-to-4) tangential relationship, but the sine value (or the relationship between the vertical side and the hypotenuse) is 0.71. That is, the side is only 0.71 as long as the hypotenuse of the triangle.



The Fibonacci result from movement of the axis of a circle

The basic relationship of the Fibonacci numbers begins with a square and results in the formation of the Golden Rectangle. In Fig. 2.7, we illustrate how this rectangle is formed.

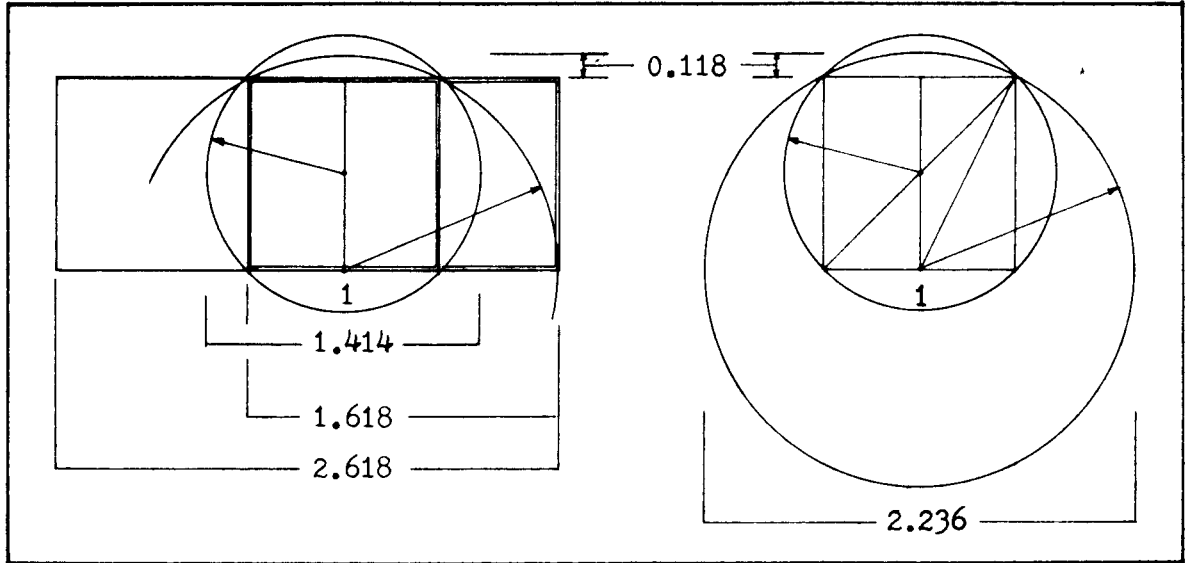

Fig. 2.7—How to build the Golden Rectangle of the Fibonacci series by movement of an axis.

To build the Golden Rectangle, we bisect the square vertically and, from the intersection of the bisecting line and the base of the square, we draw an arc through the upper corners of the square. When the arc is continued down to the baseline and the rectangle is completed and added to the square, the Golden Rectangle is apparent as the double-lined figure in the drawing. As we can see, the rectangle has a relationship of 1:1.618 to the square, since the addition caused by the arc adds 0.618 inches to the original 1-inch square. If we desire, we can add to this eye-pleasing shape by drawing another square alongside the original square, so that the new proportions are 1:2.618, which is the square of the Fibonacci (ϕ).

On the right side of Fig. 2.7, we have redrawn the original square and enclosed it in a circle, drawn the arc which created the Golden Rectangle and continued the arc full circle. Now, we find, we have created another relationship between the square, the enclosing circle and the large circle. That is, the diameter of the larger circle is 2.236 inches instead of 1.414 inches. How do we know that the diameters are this length?

First, we see that the small circle's axis is in the center of the square, so that it is on a 45° angle if a line is drawn between the corners of the square, and, from Fig. 2.1, we know that the tangent value of 1.00 at 45° has a sine value of 0.71 (or 0.70711 carried to five places), so that if we divide the side (1.0) by the sine value, we arrive

at a length of 1.4142071 for the hypotenuse of the triangle or the diameter of the circle.

The same method works for the larger circle, but here the relationship of the sides is no longer 45° but $63^\circ 26'$ (a 2-to-1 relationship), which has a tangent value of 2.00 and a sine value of 0.89441—or the 1-inch side of the triangle is 0.89441 as long as the hypotenuse. When we divide the side by the sine value, we arrive at a length of 1.1180554 as the length of the hypotenuse, or the radius of the large circle. Since the diameter equals two radii, we know that the diameter of the larger circle is 2.236 inches compared with the 1.414 inches of the smaller circle.

Now we can see, from the figure, that the enlargement of the original circle derived from the movement of the axis of the original circle from the center of the square to the baseline. Since this movement changed the angles between the side and the hypotenuse of the triangles, there was a change in the sine values of the angles. Since the side remained constant at 1 inch in both the square and the rectangle, the enlargement of the radius of the circle (0.118) derived from the change in value of the sine. That is, the movement of the axis resulted in an added length for the radius of the new circle.

The Fibonacci ratio is the sum of a square, a thrust and the phi (ϕ) additive

In Fig. 2.8, we carry the movement of the axis shown in Fig. 2.7 a little further. The figure is made the same way as was Fig. 2.7, but some things have been added: (1) We have drawn within the original square and circle (shown in heavy black) a second black circle which remains within the confines of the sides of the square. (2) We have done the same thing within the confines of the enlarged square (shown in light double lines), so that, except for size, the two sets of circles and the two squares within the two sets of circles are identical. (3) We have added to the drawing a black looping line which is indicative of a thrust (upward movement) and a recoil (downward movement). Over the whole drawing we have placed a $\frac{1}{2}$ -inch grid for measurement purposes. Now what does the drawing show?

The drawing represents how cycles grow—by a combination of thrust, plus the additive factor which derives from the Fibonacci relationship of a square and a resulting rectangle. For instance, if we assume that, from the original square and circles, the illustrated thrust carried up an inch (or reached a 2-to-1 relationship with the original radius of both the circle and square) and also assume that the illustrated recoil carried back to the top of the square and circle, we can see that the second cycle (the light lines) reached a proportion of 1:1.6180 with the original square. Now where did this amount derive from?

Half an inch of the increase resulted from the net $\frac{1}{2}$ -inch movement of the axis of the new circle from the previous position, and 0.118 inches was added by the phi factor.

Now, when the recoil carried the enlarged cycle back to a new balance, as indicated by the enlarged light square in the new cycle, the resulting square also was enlarged in the same proportion. The radius of the original circle, we remember, was 0.70711 inches long and the radius of the new circle and square is now 0.7905 inches



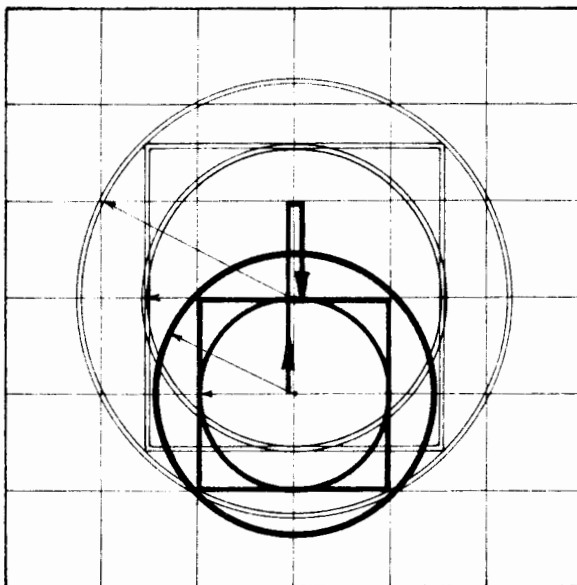

Fig. 2.8—How cycles grow from a thrust, a recoil and the Fibonacci (ϕ) additive.

long (0.70711×1.118). The enlargements of both the radius of thrust, represented by the *large* light circle, and the radius of recoil, represented by the *small* light circle (and square) are in the same proportion.

We can see, then, that an essential factor in the enlargement of a cycle is the Fibonacci additive (0.118). That is, the original 1-inch square in Fig. 2.7, was enlarged by two factors: The 0.500 inch from the downward movement of the radius plus the 0.118 enlargement of the radius by the changed angle (from 45° to $63^\circ 26'$) and the resultant change in the sine value (from 0.70711 to 0.89441), so that, in the division, the 0.118 factor was added to the original length. The new dimensions of 1.618, then, come from the 1 inch of the circle and square, plus the 0.500 inch from the movement of the axis, plus the 0.118 inch from the sine value change. The reciprocal ratio, 0.618, of course, is the thrust and recoil alone, without the original square, plus the phi additive.

The Fibonacci (ϕ) additive is a portable value

In Fig. 2.9, we enlarge upon the previous drawings by showing a series of thrusts and recoils and the subsequent enlargements of the original cycle. In the figure, we also show heavy black parabolas which indicate the maximum effect reached by each thrust.

The first thrust carried the axis up far enough so that we could stack a second identical square on top of the original square and still be within the circumference of the second circle. The second and third thrusts had the same effect, so that a total of three small squares could be stacked on top of the original square and still be within the circumference of the largest circle.



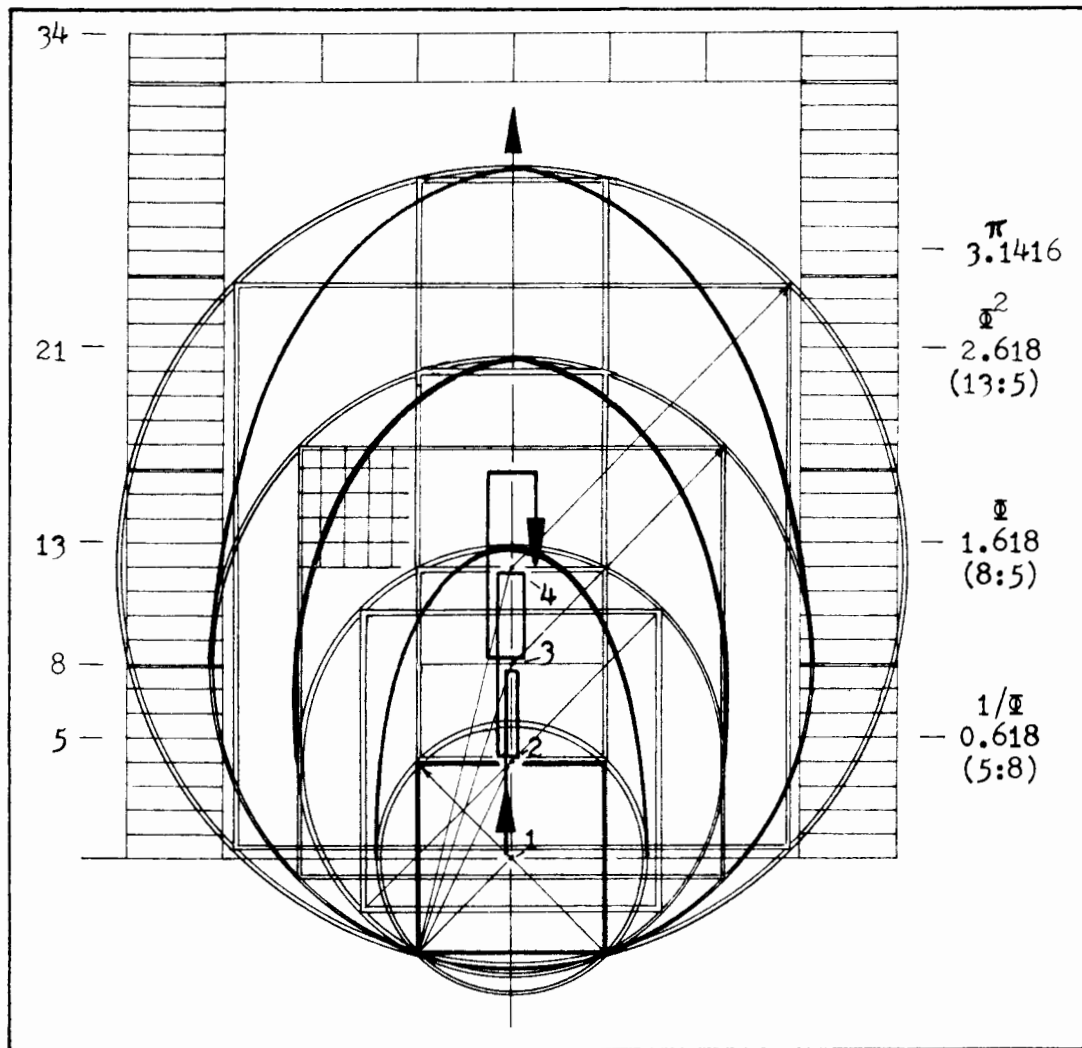

Fig. 2.9—How a cycle grows from a series of thrusts and recoils.

The small squares (which become rectangles) illustrate a series of thrusts. All of the squares are of identical size as the original square and each resulting rectangle has the same relationship with its enlarged circle as was reached by the original square and circle. That is, the original square intersected the circumference of its circle at all four points of the square. The rectangle formed by the original square and the first added square also intersects the second circle at four points: two points from the original square and two points from the added square. The same thing is true of the other rectangles (in 3-to-1 and 4-to-1 rectangles) and their respective circles. What we are trying to show is that, no matter to what size a cycle may grow, it always maintains a direct relationship between its new dimensions and the dimension of its original base. How do cycles retain this relationship?

The answer derives from the implication that all thrusts of a cycle (or an organism) are of about the same degree and result in about the same amount of recoil. A spring is a spring and the growth which derives from each year's thrust of a perennial plant is about the same. When each year's growth is added to previous growth, the size of the plant is enlarged but the basic relationship from which it started is mostly unchanged.

Now there is another relationship visible in Fig. 2.9 which is not immediately obvious. On the right margin of the drawing, we have added the Fibonacci (or phi) ratios as a scale. As we can see, the 0.618 ratio is higher on the scale than the original square and slightly lower than the circumference of the first circle. The 1.618 ratio is identical with the top of the second circle and the 2.618 ratio is slightly higher than the circumference of the third circle.

We can see, then, that, starting from the axis of the first circle and a value of 0.500, the 0.118 value of the phi additive factor held close to its value all the way to the top of the figure. That is, the second circle is the 0.500 inch of the first square, plus the 1 inch of the second square, plus the 0.118 of the phi additive. The third circle is the same, except that while another inch is added by the third square, the circle did not quite enlarge by the 0.118 phi additive. For practical purposes, however, we can say that the phi additive is portable. That is, it holds mostly true, regardless of what base it is attached to—whether 0.500, 1.500 or 2.500.

Also, on the right margin of Fig. 2.9, we show the relative location of pi (π), which is used to determine the circumference and also the area of a circle by the length of the radius. Now pi is not so irrational a number as it appears to be at first glance, once we understand the phi factor. That is, pi is the value of 3 plus 1.2 times the Fibonacci additive of 0.118—or 3.1416, minus 3, minus 0.118 leaves a value of 0.0236. On the left margin of the figure, we have placed the Fibonacci numbers. The scale is indicated in eighths of an inch so that the Fibonacci number of 13 is really 13 eighths up from the axis of the original circle and square. The figure of 21, which is extremely close to the 2.618 of ϕ^2 , is $2\frac{5}{8}$ inches.

The mechanics of a thrust and a recoil

There are some mechanics involved in a thrust and a recoil which we need to understand before we go further, and these we illustrate in Fig. 2.10.

First, the figure was drawn by moving an axis for a circle equal distances up the vertical axis and connecting the ends of the arcs of the circles in the upper half of the drawing with points at the same equidistances on the horizontal axis as on the vertical axis. From these intersections of the arcs and the horizontal axis, straight lines were drawn to the points on the vertical axis which were used as axes for drawing the arcs. The straight lines, then, are really the radii used for the drawing of the arcs.

Second, we can see that the drawing is really made in two principal parts. The lower section illustrates the tangent ratios between a thrust and a recoil, or between advances and declines, or between buying and selling volume, as we shall see. Since the forces operate at a right angle, the lines in the lower portion are hypotenuses of the triangles involved. The upper section illustrates the response cycles make to the



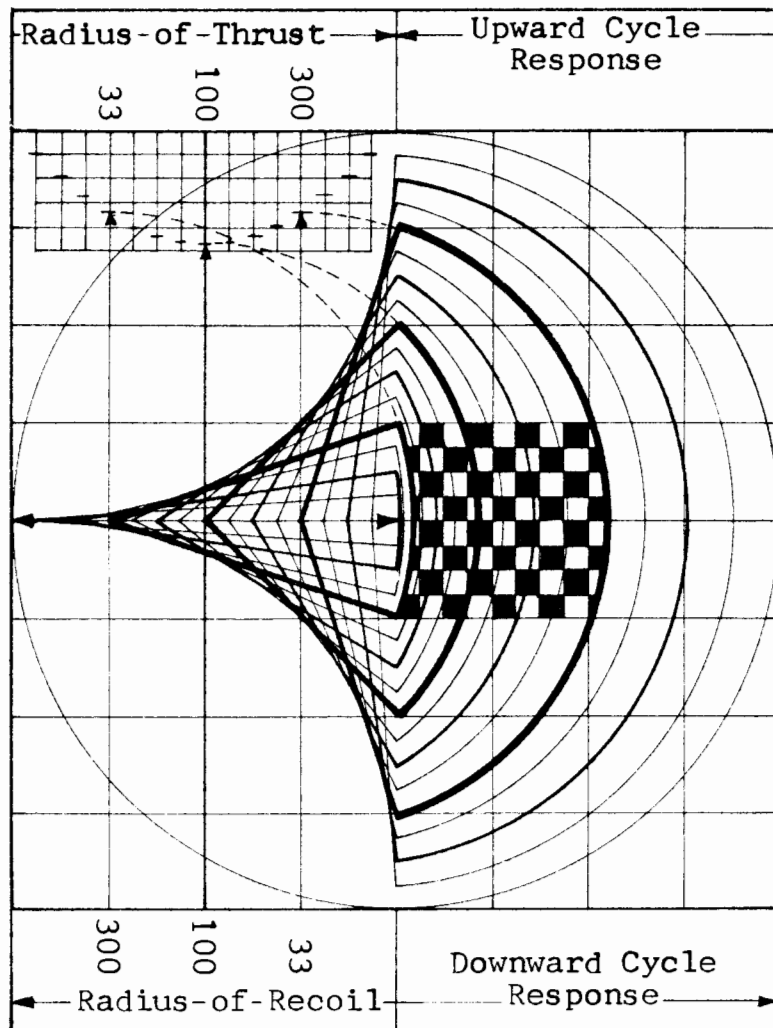

Fig. 2.10—The mechanics of a thrust and a recoil—and how the Fibonacci control growth.

ratios set in the lower portion of the chart. That is, as the angles of the lines change as the axes of the radii move, the radius lengths change.

As we can see in the small chart in the lower left corner, from the bottom the radii enlarge as they approach 45° , and beyond 45° they get smaller in the same proportions as the increases. That is, as we can see from the dashed lines, the lowest of the heavy black arcs in the upper portion indicates that it was drawn with a radius equal in length to the distance from the vertical axis to the end of the lower arrow. The central black arc was drawn with a radius which is shorter, as we can see, and the highest black arc had a radius equal to that of the bottom arc.

Now when we draw the arcs in the upper portion of the figure, we can see that,

even though the upward steps of the axes in the lower portion of the chart are equal, the cycle response, or the placement of the arcs in the upper portion, moves in unequal steps. That is, in the lower portion, the axis of the lowest of the heavy black triangles and the axis of the highest are each $\frac{1}{2}$ inch from the axis of the center triangle. In the upper portion, the lowest of the arcs is only about $\frac{3}{8}$ inch lower than the center arc but the upper arc is nearly $\frac{3}{4}$ inch above the center arc.

From the arrows in the margin, we can see that the upper portion of the figure is inverted in its values. That is, as a thrust moves up the vertical axis in the lower portion, the grid in the upper portion indicates that the thrust moves more rapidly as the thrust continues. This is the reverse of what happens, since the upper portion of the figure is inverted in relation to the lower portion. When a thrust moves up from the bottom of the lower portion of the figure, the response of the cycle comes down from the top of the upper half and moves down toward the central horizontal axis. The response of the cycle is opposite that of the thrust itself in this drawing.

We also can see that the central arc derives from a 45° relationship of the radii from which it springs, or that the forces involved are at a 1-to-1 relationship. Regardless of what may appear in the drawing, then, the central arc is the mathematical center of the upper portion, since it has a value of 1.000 and is the balance point around which cycles swing.

The Fibonacci values control the growth of a cycle

In the upper center of Fig. 2.10, we have drawn a checkered area between the highest and the lowest heavy arcs. This checkered area is the control area of the Fibonacci relationships.

This is apparent in Table 2.1, which indicates the response of cyclical thrusts and recoils to the power of the forces in the lower portion of the chart. For instance, at 45° and at a tangent value of 1 (the central black arc), a cycle is balanced because its forces are in a 1-to-1 balance. At 3-to-1, at $71^\circ 34'$ and a tangent value of 3.00, the lowest of the arcs in Fig. 2.10, there is a 3-to-1 imbalance of force between thrust and recoil. That is, the thrusting force is three times as strong as the recoiling force at this point.

At the opposite end of the table, at a relationship of 1-to-3 between recoil and thrust, the angle is $18^\circ 26'$, the tangent relationship is 0.3333 and the recoil is three times as strong as the thrust.

Now in Column 5 of the table, we indicate the response a cycle makes to the various relationships between the two forces. When a recoiling force is three times as strong as a thrust, the thrust has a value of 3.1626. This is figured by translating the tangent value into the sine value for that angle and dividing one (1.000) by the sine value. Now when the thrust has moved up from the 1-to-3 ratio and is in a 5-to-8 ratio with the recoil, the cycle response factor is 1.8871. By the time the thrust has reached a balance, the response factor has diminished to 1.4142, and by the time it reaches 8-to-5, the response is reduced to 1.1792. The further the relationship goes in favor of the thrust, the smaller the response to the thrust becomes, as we can see.

We have divided the table into portions, with the extreme values at each end



Table 2.1—Cycle response to the tangential ratio of opposing forces.

	(1) <i>Balance of Force Between Thrust & Recoil</i>	(2) <i>Tangent Value of Balance</i>	(3) <i>Angle from Horizontal</i>	(4) <i>Sine Value of Balance</i>	(5) <i>Cycle Response (1 ÷ Sine)</i>	<i>Ratio to Central Value</i>
1	8 - to - 1	8.0000	82° 52'	0.99226	1.0078	
	8 - to - 2	4.0000	75 58	0.97015	1.0308	
	3 - to - 1	3.0000	71 34	0.94869	1.0541	
2	8 - to - 3	2.6667	69 26	0.93626	1.0681	0.9553
	ϕ^2 - to - 1	2.6180	69 06	0.93420	1.0704	0.9573
	2 - to - 1	2.0000	63 26	0.89441	1.1181	1.0000
	ϕ - to - 1	1.6180	58 17	0.85066	1.1756	1.0514
	8 - to - 5	1.6000	58 00	0.84805	1.1792	1.0546
3	8 - to - 6	1.3333	53 08	0.80003	1.2500	
	8 - to - 7	1.1429	48 49	0.75261	1.3287	
	1 - to - 1	1.0000	45 00	0.70711	1.4142	
	7 - to - 8	0.8750	41 11	0.65847	1.5187	
2	6 - to - 8	0.7500	36 52	0.59995	1.6668	
	5 - to - 8	0.6250	32 00	0.52992	1.8871	0.8440
	1 - to - ϕ	0.6180	31 43	0.52572	1.9022	0.8508
	1 - to - 2	0.5000	26 34	0.44724	2.2359	1.0000
	1 - to - ϕ^2	0.3820	20 54	0.35674	2.8032	1.2537
1	3 - to - 8	0.3750	20 34	0.35130	2.8466	1.2731
	1 - to - 3	0.3333	18 26	0.31620	3.1626	
	2 - to - 8	0.2500	14 02	0.24249	4.1239	
	1 - to - 8	0.1250	7 08	0.12418	8.0528	

(1), the Fibonacci area values in the center of each half (2) and the central values (3) in a group. From this arrangement, we can see that the Fibonacci area, bounded by 8-to-3 and 8-to-5, and the inverse, occupies a large part of the table. Also, we see that ϕ and ϕ^2 lie on the opposite sides of the 2-to-1 ratio, and, from column 5, that the response values of cycles are little changed from one end of this Fibonacci area to the other. That is, at an 8-to-5 ratio, response is 1.1792 and at an 8-to-3 ratio, response is 1.0681. From the central 2-to-1 value, we see that the difference between the central value and the extremes is only about 5/100ths on either side. Now we can see the basis for our earlier statement that the Fibonacci additive is portable. Over an 11° swing of a cycle, there is only 9.9/100ths difference in the extension of the radius of a cycle in this area.

There is another aspect here, too. When a cycle is in full recoil or is approaching

the bottom of the table (and the top of the upper portion of Fig. 2.10), the response of the cycle is much larger than at the other extreme. That is, when a thrust rebounds from a trough, it moves much faster than when it is approaching its peak. When a recoil has pushed a thrust down to a 3-to-8 ratio of force and the thrust turns at the cyclical trough, it will move upward at roughly three (2.8466) times the speed as when it is approaching an 8-to-3 ratio with its opposite (1.0681) number. As a cycle travels upward, then, an increase in the amount of upward force causes a decreasing rate of movement, and, especially after reaching the balance point, an upward movement of a cycle runs into constantly increasing resistance.

On the downside, of course, the opposite is true. As a cycle peaks out and starts down, it moves slowly at first and then picks up speed as it passes the balance point. When it is nearing the ϕ^2 value, it is moving nearly three times as fast as at the start. The old market saying that prices fall of their own weight is true, we can see, since the momentum of a downturn is loaded on the downside, and the downward move will not slow and turn until sufficient volume of buying comes in to halt the decline.

In this section, we hope we have demonstrated that there are really two systems at work within the cyclical mechanism. First is the system of thrust and recoil which causes cycles to get larger, or grow, and second is the Fibonacci control system which makes it harder and harder for a force to move a cycle as it increases its superiority over its opposite number. When a cycle reaches the area of the Fibonacci ratios, increased force by a thrust meets more and more resistance, and the rate of growth is slowed at a faster and faster pace as the imbalance grows.

This, of course, is what happens in nature, as well as in cycles. The growth rate of plants is much faster in the spring, slows in summer, slows still more in the fall and stops in the winter. A baby grows at a faster rate than a child, and a child than a youngster, and a young adult than a maturing individual.

The difference with cycles is that, when a growth has stopped, a reversal of direction must set in. Cycles run up to their asymptote or reversal area, complete the reversal and run down to the lower asymptote, from which the whole process starts again. Regular cycles, then, grow at an average, predictable rate of speed and decline at an average, predictable rate of speed, so that the length of a cycle is best measured by the vertical radius (amplitude) from trough to peak—since measuring by time is only to add another variable factor into the cyclical equation.

The Golden Section and the Great Pyramid of Egypt

In his magnificent book, *Secrets of the Great Pyramid*, Peter Tompkins has a fine chapter on the Fibonacci relationships visible in the pyramid. Here are some excerpts: *

"The Pyramid is so designed that for all practical purposes it accomplishes the squaring of the circle . . .

* From *Secrets of the Great Pyramid*, Peter Tompkins, © 1971 by Peter Tompkins. By permission of Harper & Row, Publishers, Inc.



“Although the squaring of a circle is an insoluble problem if you use the irrational number of π , it is nevertheless practically resolvable as a function of the Golden Number ϕ . Because $\pi/2 = 2/\sqrt{\phi}$ to within a thousandth part, π can usefully be taken as $4/\sqrt{\phi}$ Because π also equals $\phi^2 \times 6/5$, it is possible to use the Fibonacci series to obtain an accurate relation for the diameter of a circle to its circumference without recourse to π . In the Fibonacci series of 21-34-55, if 21 is taken as the diameter of a circle, its circumference will be $55 \times 6/5$, or 66, accurate to the one-thousandth part . . .

“In the Great Pyramid, the ϕ relation is found in the triangle formed by the height, the half-base and the apothem; that is to say, in the basic *cross-section* of the structure. These proportions create a relation between the sides of the triangle such that if the half-base is 1, the apothem is ϕ and the height is $\sqrt{\phi}$.”



How Volume Powers the Cycle Mechanism **3**

In the last section, we saw that cycles result from two continuous operations: (1) a series of thrusts from a point (or square) of equilibrium and (2) a resulting series of recoils back to a new square of equilibrium.

Since the entire movement can be defined as the enlargement of a square—or a two-dimensional result—and since we know that whole volume is one-dimensional, since it merely rises and declines in quantity, we can see that the one-dimensional thrust of volume results in a two-dimensional effect. If you hold a tomato in one hand and hit it with the other, the tomato squashes—but the principal effect is that the juices squirt out at right angles to the thrust.

We can consider, then, that if the force of a thrust is expended vertically, the force of a recoil is expended horizontally.

Now it is obvious that, if volume is not the cause of a thrust, it at least is the evident reason why prices move in the market, since prices rise on rising volume, so we need to see some of the things that happen to a cycle when the force of volume is applied to the cycle mechanism.

I—Volume Alters Basic Cyclical Shapes

Perhaps the easiest way to understand a cycle mechanism is to think of a cycle as an automobile wheel and price as the valve stem of a tire. When a wheel revolves, the valve stem (1) must travel in a circular path. (2) must move up and down and (3) must move laterally as the wheel rolls on the ground. When a cycle revolves, price must follow a path similar to that of the valve stem on an auto wheel.

For instance, in Fig. 3.1, cycle 1 illustrates



what happens when a wheel is turned at a speed of one-half circumference at each time unit (the scale at the top of the chart). When the wheel is revolved half a circumference (or one diameter), the valve stem of price which was at the bottom at point 0 moves upward to the top of the wheel at point 1, back down at point 2 and upward again at point 3, as illustrated by the heavy black line which connects the points. Actually, the movement is not a straightline path from point 0 to point 1 but an S-curved, upward motion to point 1, and, to point 2, an S-curved motion which is the mirrored reverse of the first movement. This is the basic cyclical path which price travels—up and down at regular intervals of time, so that the radius determines the length of the vertical (or price) amplitude of a swing and the diameter determines the length of the horizontal (time) swing of each leg.

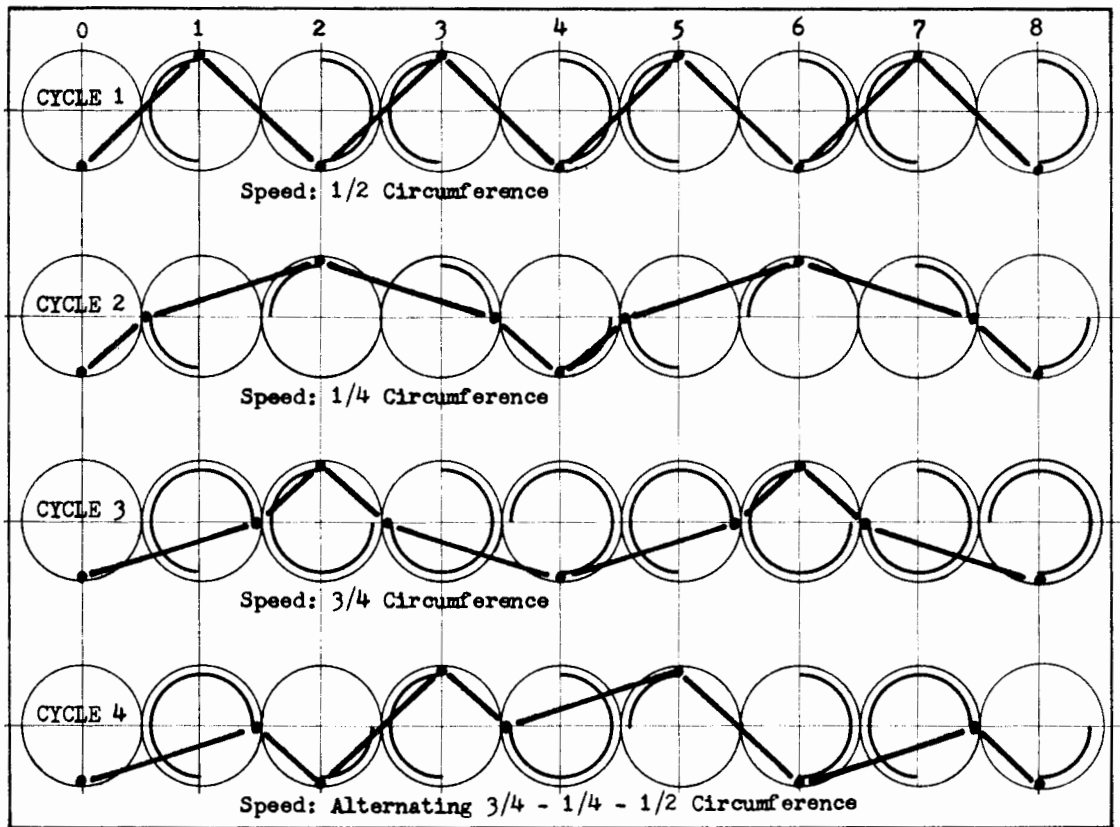

Fig. 3.1—The effect of varying speeds of revolution on a single cycle.

Now cycles, as we know, are not rigid affairs like an automobile wheel. That is, cycles result from the net difference between a thrust and a recoil, and, since the thrust will not always be exactly the same, the recoil will also differ in its reaction. The mechanism of cycles, however, will tend to produce similar results at each revolution, so that

the differences between repetitions of price cycles will be more the result of changes in thrust than of alteration of the mechanism itself.

The effect of the quantity of volume on a cycle

Neither is a cycle an arrangement which flies apart under stress. That is, while the mechanism may adjust to circumstance, it will continue to operate. It may appear to have broken down or changed its character, but, sooner or later, it will reappear and operate again on its expected frequency if it is a true harmonic cycle.

For instance, some strange things can happen to the basic cyclical movement we demonstrated with cycle 1 in Fig. 3.1. One of the largest effects comes when the speed of a movement—or the time element involved in one rotation of the valve stem of price—is either increased or decreased. Cycle 2 illustrates the shape the basic movement takes when the speed is reduced to a quarter turn—or the time element per revolution is doubled. That is, in the first cycle, one full rotation was completed in two time units. In cycle 2, the rotation requires four time elements, so the cycle, instead of being a two-legged affair, now has four legs—or two different pairs of legs in each revolution.

In cycle 3 in the illustration, the speed of the movement is increased so that, instead of turning a half revolution in one time unit, the cycle is now travelling at three-fourths of a revolution in one time unit. In this case, the cycle duplicates cycle 2, except in a reverse pattern, which is a half-cycle out of phase with cycle 2 but which still requires four time units to complete its upward and downward movements. Both cycle 2 and cycle 3 have become, in effect, double cycles, since the movement now takes twice as much time as the basic cycle.

In cycle 4, we see what can happen to a cycle when it is subjected to varying speeds—in this case, a change from $\frac{3}{4}$ to $\frac{1}{4}$ to $\frac{1}{2}$ to $\frac{3}{4}$ revolutions in each time period. Now we commence to see a pattern which resembles those we find in stock charts. When we consider that volume fluctuates in quantity, as well as imbalance between buying and selling, we can understand why cycle 4 bears a resemblance to a stock chart, and we also can see that price sometimes traces odd patterns even though it is following a regular cyclical path.

We noted that cycles 2 and 3 extended lengthwise into what amounted to double cycles—or a cycle twice as long in time—compared to cycle 1, and that the difference between the cycles was the speed of revolution of the hypothetical cycles. That is, cycle 2 travelled at half the speed of cycle 1 and cycle 3 at $1\frac{1}{2}$ times the speed of cycle 1—with the same general pattern result as in cycle 2. Now the only thing which changed between the three cycles was the speed of revolution. Speed, of course, is an expression of force. When you push down on an accelerator, more gas flows to the engine, more power is generated and the speed of the car increases. When you ease up on the accelerator, the speed decreases.

As we learned in Chapter 2, volume fluctuates in quantity, and when volume in the market is increasing, prices tend to rise. When volume is decreasing, prices tend to decline. Since cycles 2 and 3 were subject to, respectively, less force and greater



force, we can imply that volume is a force which causes alterations in the shape of cyclical rhythms in the market.

Now if we look at Fig. 3.1 and visualize volume as the force which powers cycles, we can see that a thrust of increasing volume is what carried cycles upward and the recoil of declining volume is what returns them to equilibrium. From cycle 2, we can see that low-volume cycles are slow-moving cycles in which the final amplitude comes on the second thrust of volume, and that recoil movements also come in two slow stages.

The same thing, in reverse, is true if there is too much volume as in cycle 3. That is, when volume is excessive, prices reach a low peak while the thrust of heavy volume is still continuing. This is followed by a fast-peaking move, and when the peak is reached, the recoil from the peak will also be fast and excessive, followed by a long decline so that the cycle is expanded in time—or takes longer to complete its full recoil.

If you've ever traded, you know what we mean. A stock makes a good small move in a hurry and then dawdles while you wonder what is going to happen. It makes a final thrust to its peak before you are really aware of what is going on and quickly subsides, so that if you didn't grab your profit near the peak, you had little or none left. When it became unprofitable, of course, the stock further eroded slowly in price while you were waiting for the next upswing so you could get out with a whole skin.

Too much or too little volume makes for quick thrusts and long in-between, nerve-wracking waits.

When buying volume expands, selling volume contracts

Perhaps the reason so little is really understood about volume is that it is basically triangular in nature. The whole-volume figures which are reported by the exchanges each day are really three figures—or have two parts within a whole:

- (1) Whole-volume figures, which are a single count of the transactions, even though each transaction was between two parties, a buyer and a seller.
- (2) Buying volume, or the volume which derived from rising prices.
- (3) Selling volume, or the volume which derived from falling prices.

Whole volume is the sum of buying volume and selling volume, but the relationship of the three parts is not a simple $1+1=2$ equation. Instead, the market moves in relation to (1) whole volume and (2) the balance between buying volume and selling volume. As we have seen, the DJI tends to move upward as volume increases. This is because in an increasing whole-volume situation, buying volume is increasing faster than selling volume. The balance of power lies with buying in an upward market and with selling in a downward market—despite the fact that for every buyer there has to be a seller.

The reason the market can get away with this seeming imbalance of force and still retain equilibrium at all times is that buying and selling volume are two parts of the whole total of volume. That is, if total volume always equals 1.0000, it does not necessarily follow that buying must be 0.5000 and selling must be 0.5000. The balance between them can shift, and does, so that at times buying can equal 0.6000 or more



parts and selling can equal 0.4000 or less parts of the whole—and at others selling can equal 0.6000 parts—without upsetting the balance, because the two parts together equal a single whole. Part of the reason selling can exceed buying—and buying can exceed selling—is the short interest of the market. The short interest is basically non-existent shares since the shares sold short are borrowed stock.

Now when we have a situation in which two contained parts must always equal the total, one force can expand only at the expense of the other. That is, when buying is increasing, it can increase only if the quantity of selling is reduced, if whole volume remains constant. The side which is reduced, then, is under considerably more pressure than when the two forces are equal. If selling is reduced to 0.4000 and buying increases to 0.6000, the selling side is under much more pressure than the buying side and a reaction will arise from the selling pole of the buy-sell axis. The reaction of the selling force will carry the two forces at least back to a balance—usually beyond equilibrium. This reaction is visible in a rubber band.

When a rubber band is stretched, its opposing forces are pulled out of the balance which exists when the band is relaxed. The force which is being pulled is enlarged by the application of outside pressure and the force which opposes the pulling is compressed into less and less space as the pulling continues. When the pull is suddenly released, the band flies back, first to equilibrium and then beyond. When equilibrium is passed in the reaction move, the whole band will fly in the direction of the force which was compressed by the pulling.

Prices only indicate subsurface conditions

From this situation, we can see an implication that the cyclical forces of the market resemble the forces of a rubber band. When selling volume increases and increases, it will eventually reach a point of elastic limit; the compressed buying volume will then react and drive prices up at least to a point at which the two forces can reach an equilibrium.

It is important to remember that prices are merely an indicator of what is happening to the underlying forces. Price rises like a rubber duck in a bathtub when water is pouring into the tub, and it falls if the level of water in the tub is lowered. The duck doesn't change its relationship with the water level, but the water level changes and carries the duck with it. Prices are rubber ducks on an undulating surface, which is why there is no longer such a thing as "value" in the market—only undulating prices.

Price cycles in the market, then, are really products of the constantly alternating upward and downward adjustments between buying and selling pressures, since prices flow in the direction of the dominant force. Price cycles are the visible paths which stocks follow as the underlying volume forces alternate between positive and negative.

Since a price cycle is an extension, through the price mechanism, of the buy-sell relationship, cycles provide the means by which the volume forces can regain equilibrium even when buying or selling remains dominant. A cycle normally will move from its low to its maximum and back to the low, as we saw in Fig. 1.6. If there is a trend present, the second trough of the cycle can remain higher than the first trough and still reach equilibrium of its forces. As we pointed out, if trend has an upward value



of two and the cyclical value is two, the downward leg of the cycle would be likely to reach equilibrium at the trendular value of two, instead of reverting back to zero. The relationship of buying and selling volume will be at zero or equality, but price, because it must also accommodate trend, will be higher than at the first trough.

How one force can increase and also remain equal to its opposite

When a price cycle is adjusting and the buy-sell relationship of the market is getting back to equilibrium, the cycle mechanism is operating as an epicycle. An epicycle is a combination of movement of two or more cycles (or circles) with the smaller one operating on the circumference of the larger cycle. As the larger cycle turns, the smaller cycle also turns—but at a faster speed than the larger cycle, since it is turning on the circumference of the larger cycle, as we illustrate in Fig. 3.2.

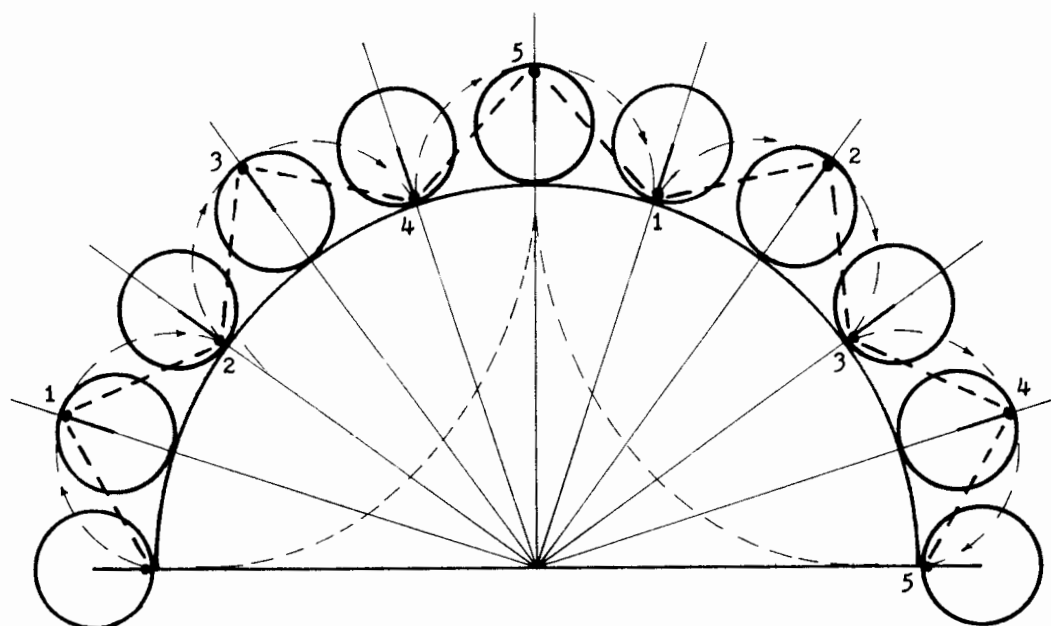

Fig. 3.2—The epicyclic arrangement of market cycles in a schematic drawing. The dashed curve represents volume buildup.

An automobile mechanic knows an epicycle as the differential gearing or the “rear end” of an automobile. In a car, the differential gearing is an arrangement of gears which connect the two rear axles of the car and the power train. The differential allows the driving force of the engine to be equally divided between the two rear wheels—but it also allows one wheel to revolve faster than the other, when required. If cars did not have differentials, when a car was being driven around a corner or a curve, one wheel would be dragged by the other, since, on the parallel curves of the two rear wheels, the wheel on the outer curve travels a longer distance than the wheel on the shorter curve, which is closer to the center of the curve around which the car is travelling.



In the market, the power of whole volume is equally divided between buying and selling volume, but one force can grow or revolve faster than the other because of the epicyclic arrangement of the cyclical “gears.” Volume thus is equally divided between buying volume and selling volume (“a buyer for every seller”), just as an engine’s thrust is divided equally between the two rear wheels of a car—but one force can build to a greater total than the other because it “travels” farther on exactly half of the thrust. When the buying “wheel” of a cycle is travelling faster—or a longer distance—than the selling “wheel,” this differential between the two equal forces expresses itself in rising prices, since cycles are the expression of differences between buying pressure and selling pressure. That is, price does not express direct pressures of buying and selling but indirect pressures which are the sum of the difference between the two forces. When these indirect pressures reach a cycle’s elastic limit, the cycle will reverse at least back to the point of equilibrium, and sometimes the reversing forces will carry beyond, as in the case of the flying rubber band. Remember that a cycle’s elastic limit is a combination of tension and time, so that the reactions come at regular time intervals.

How epicycles “crack the whip” at market tops

Now in the final thrust of a strong upward movement, prices tend to move upward much faster than whole volume. For instance, in Figs. 3.3 and 3.4, we have illustrated the final thrusts of the 1929 runup and of the 1966 top. Overlaid on both the price curves and the volume curves we have placed dashed parabolic curves. In Fig. 3.3, we can see the dramatic 1929 upward rush of prices from the 220 level to the top as indicated by parabola P^2 . We can see that parabola V^2 was largely outdistanced by the price movement far out of proportion to the balance which existed between price and volume (P^1 and V^1) during 1924–26.

This difference in thrust of the price parabolas and the volume parabolas is also apparent in Fig. 3.4. While there is fair coordination between P^1 and V^1 from 1957–62, there is a wide difference between P^2 and V^2 , since volume did not increase markedly until the middle of 1965. It was only after the June 1965 dip that volume came in strongly. Now, please, look at Fig. 3.2. Here we can see why prices get a big thrust from the final spurt of volume. As the small cycle is carried upward by the larger cycle, the final half turn of the small cycle acts like a whiplash, or a slingshot—not the type with the forked-stick but the type David used to overcome Goliath, a rock swinging in a circle in a leather pouch at the end of David’s arm.

Also in Fig. 3.2, we illustrate the effect of volume in a situation such as this. Volume, as we know, builds gradually and then spurts upward toward the end. The impetus of rapidly increasing volume, coming at a time when the smaller cycles are already swinging upward in a half-turn, gives prices their final fillip.

The epicyclic effect comes about because cycles, as we said, are really a chord of cycles. Each smaller cycle rides upon the back of each larger cycle, so that, near a peak of a large cycle, when small cycles are peaking also, prices get a whiplash effect from the action of all the cycles in the chord, just as the last man in a string of skaters “cracking the whip” really picks up speed as he turns the last curve.

Before we leave Fig. 3.2, please note the similarity with Fig. 2.1. Both “bell”

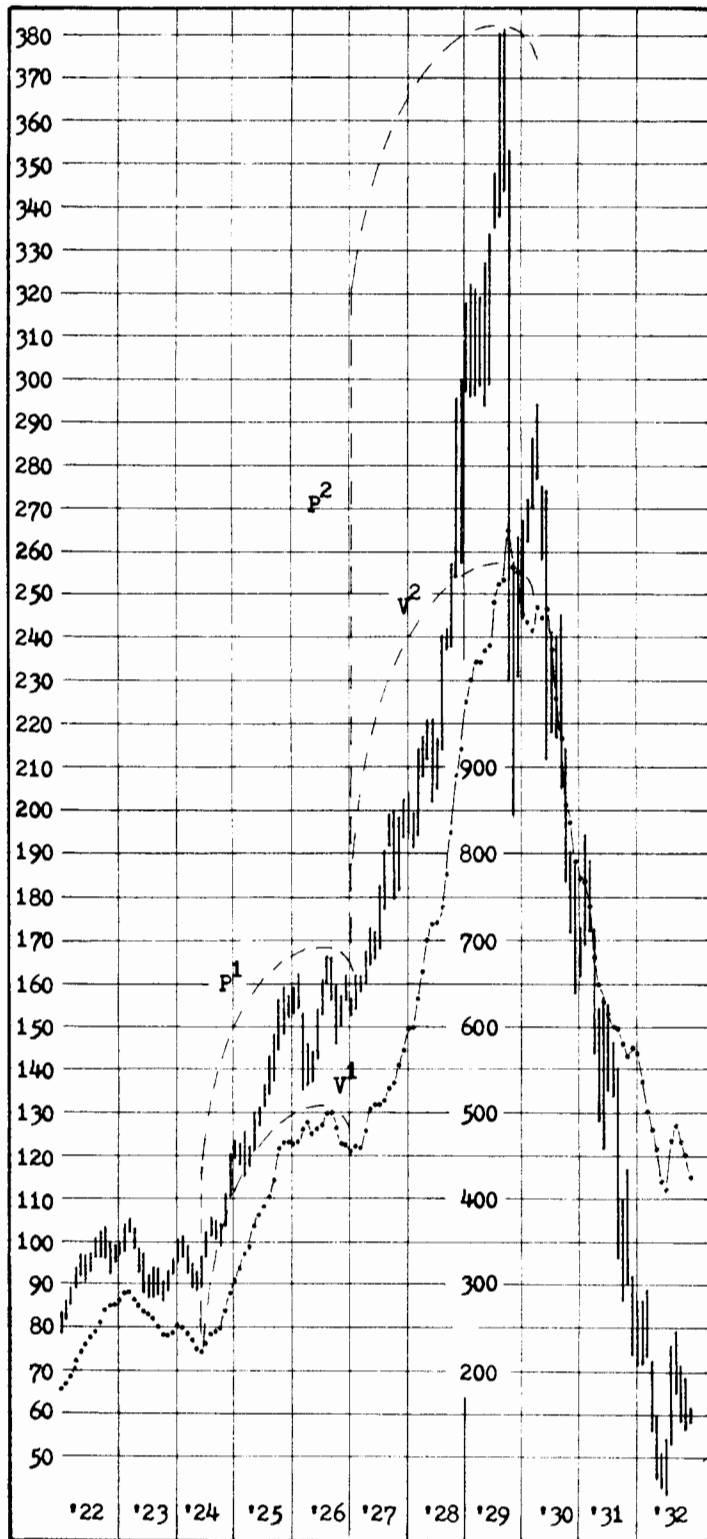

Fig. 3.3—The Dow industrial average and volume moving totals in the 1929 runup of price.



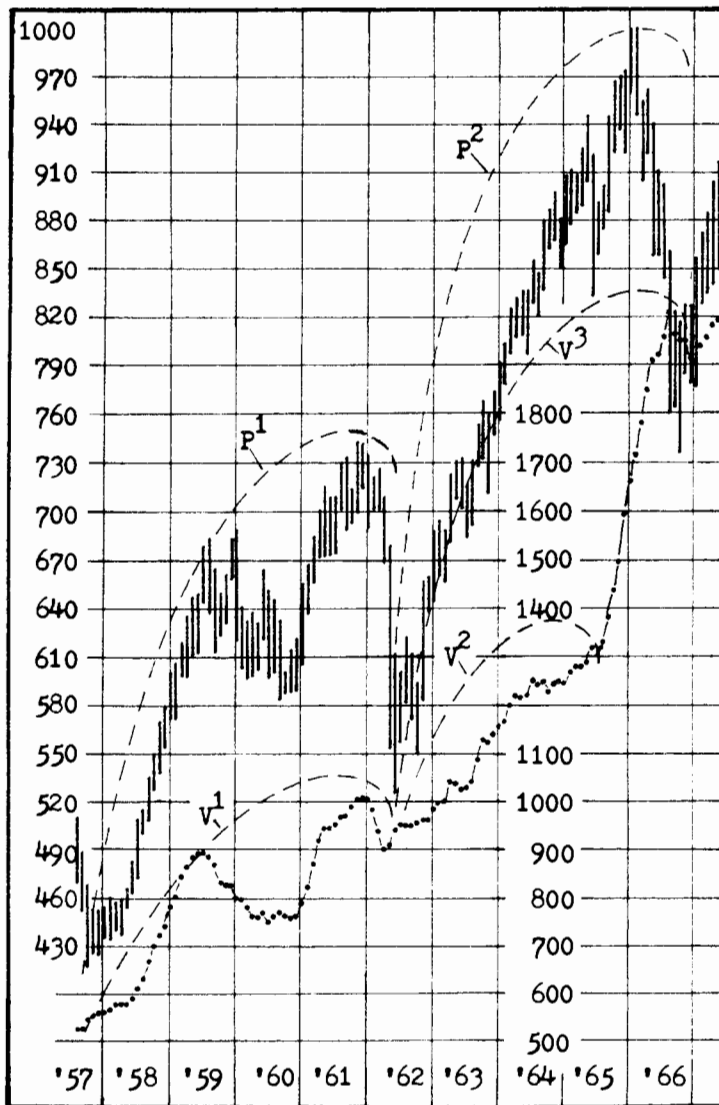

Fig. 3.4—The Dow industrial average and volume moving totals in two 4¼-year cycles, 1957–66.

outward from the buy-sell axis as they start their climb toward the tops of the force curves. In Fig. 3.2, we can see that this is a result of the epicyclic movement, so that when we connect a dot on the small cycle in the illustration with a dashed line to show its position at each point along the circumference of the big cycle, we find that in an epicyclic structure there are the makings of cycles as we know them in the market. That is, at point 1, the dot is farthest from the large cycle. At point 2, it has moved back to the circumference of the large cycle. This oscillating action, which constantly

travels back and forth in a relationship with the large cycle, is typical of cyclical action. It is easy to see why the cyclical field and the magnetic field are so similar in shape and characteristics, since both result in harmonic forcebands and emanations of force from the axis of the fields.

II—Vectors in the Cyclical Field Are Controlled by Volume

We established earlier that the forcebands which appear at harmonic price levels in the cyclical field are really accumulations of stock-to-be-sold at those levels. It would appear, then, that price is the sole determinant of when that stock will come to market, but, once again, things are not always what they seem. That is, the volume flow from the forcebands in the cyclical field is only partly controlled by the price-volume relationship.

The bulk of the stock which comes to market from the field is sold because it is either higher or lower than the purchase price. The only way you can make a profit in the market is to sell stock you bought at a low price at a price higher than the cost, plus the cost of doing business. The only way you can lose money in the market is to sell stock you bought at a high price at a price lower than the cost of the stock and the price of doing business. The only way you can be active in the market and participate in potential gains (and losses) is to be liquid, and liquidity is a big factor in bringing stock to market. That is, who wants to sit with a dead stock in an active bull market when your friends are making money?

There are many reasons, then, why stock is sold at prices other than at the price-volume relationship. Without going further into this discussion, it is evident that people sell stock for reasons other than to establish a profit, and, as we shall see, part of the reasons derive from the striking zone of the cyclical field. To do this, we need to look once more at Fig. 2.1.

Volume determines the angle of a cyclical vector

In the illustration, we drew a series of rays emanating from the striking zone and travelling across the field, from lower left to upper right. The rays cover the whole field, but to simplify the drawing, we included only those in the upper-right and lower-left quadrants.

In practice, the rays are even more invisible than the cycle mechanism, but they serve an important function inasmuch as these emanations from transactions in the striking zone are the elements which activate or “excite” the harmonic pricebands within the cyclical field. In addition, as we shall see, they are very valuable for other reasons.

On the left side of Fig. 2.1, we indicated in semi-log scale, even though the chart is arithmetic, the value of a hypothetical stock. That is, from the \$10 price to the center of the figure is one cycle (or \$10 to \$20) and in the upper part is the second cycle (\$20 to \$40). Now, by tracing the lines through the striking zone, we can see that the \$10 price is also the 45° vector. A vector is a line which represents direction and, by its length, the quantity of the force it represents.



Now, at various points across the chart, the vector intersects with all the prices indicated by the scale. That is, the vector cuts across the corners of a first square which centers between \$10 and \$12.50, a larger square between \$10 and \$15 and even the largest square on the chart between \$10 and \$40. A vector arising from the striking zone, then, can easily be seen as the hypotenuse of a series of triangles whose sides are of any apparent magnitude. Now the same thing is true of the vector along the $75^{\circ} 58'$ ray which indicates a \$10 to \$40 movement in a much shorter period of time, if we consider that each horizontal square indicates a time period. And the same thing is also true of the vector which arises at \$17.50 and terminates at $14^{\circ} 02'$, or at the \$25 value on the left.

The point of the illustration is that the vectors (rays) which emanate from transactions in the striking zone have the capability of exciting activity (or response) throughout the cyclical field. Since, as we have seen, it is from the cyclical field that the bulk of stock which is traded in the market derives, we can see that transactions in the striking zone strike harmonic chords in holders of stock at whatever price level. If the movement of a stock is swift enough, the people who hold the stock at \$40 can get just as excited as the people who hold it lower down. If the movement is slow and sluggish, however, as along the \$17.50 vector, the excitement doesn't amount to much, since the price is so far away that liquidation of a forceband at a high level is unlikely.

Now we know that the pricebands in the cyclical field are expressions of volume, just as is stock passing through the striking zone of transactions, and now we can see that it is also volume which determines the angle of the vectors. Low volume will cause little amplitude of price—and a low-angle vector—and high volume will “stand” a vector on end. Technicians call moves along the high-angle vectors “flagpoles.”

It is not only volume and price movement in the stock you own which produces “excitement” among stockholders, but also price movement and volume of other stocks. If you are holding a “dog” and waiting for it to react, you are also missing opportunities in active stocks, and this alone will result in inactive stocks coming to market, as well as exciting holders and would-be buyers of the active stock.

Vectors carry the thrust of small cycles to big cycles

Besides having the quality of “exciting” the cyclical field, the vectors in the field have two other qualities: (1) they transmit harmonic values which build the large cycles and (2) they allow us to measure the progress of a larger cycle.

We saw in Chapter 1 when we built a synthesis of cycles—which was good enough to give us a lot of clues about price movements in the market—that the building blocks of the synthesis were sine values spaced between zero and 1 according to the number of weeks we estimated to be in each cycle length.

In Table 3.1, we illustrate only part of the sine values for the synthesis, but we can see that when we have a value such as the 0.5878 in the 10-week cycle, we can connect this value to the same value in the 25-week and 75-week cycles. That is, all three of these cycles are related harmonically to each other. A value in one cycle is repeated in the larger cycles, and, of course, this is true on each repetition of the small cycle.



Table 3.1—The harmonic sine values in five cycles of differing harmonic lengths.

2-wk Cycle	10-wk Cycle	25-wk Cycle	75-wk Cycle	225-wk Cycle
1.0000	1.0000	0.9511	<u>0.5878</u>	<u>0.2079</u>
0.0000	0.9511	0.9823	0.5534	0.1942
1.0000	0.8090	<u>0.9980</u>	0.5180	0.1805
0.0000	0.5878	0.9980	<u>0.4818</u>	<u>0.1668</u>
1.0000	0.3090	0.9823	0.4446	0.1530
0.0000	0.0000	<u>0.9511</u>	0.4067	0.1392
1.0000	0.3090	0.9048	<u>0.3681</u>	<u>0.1253</u>
0.0000	0.5878	0.8443	0.3289	0.1115
1.0000	0.8090	0.7705	0.2890	0.0976
0.0000	0.9511	0.6846	<u>0.2487</u>	<u>0.0837</u>
1.0000	<u>1.0000</u>	<u>0.5878</u>	<u>0.2079</u>	0.0698
0.0000	<u>0.9511</u>	<u>0.4818</u>	<u>0.1668</u>	0.0558
1.0000	0.8090	<u>0.3681</u>	<u>0.1253</u>	<u>0.0419</u>
0.0000	<u>0.5878</u>	<u>0.2487</u>	<u>0.0837</u>	0.0279
<u>1.0000</u>	0.3090	<u>0.1253</u>	<u>0.0419</u>	0.0140
0.0000	0.0000	0.0000	0.0000	0.0000

If the same sine values do not occur in two cycles, say, the cycles are not harmonic with each other and are probably highly incompatible—so much so that it leads us to believe that nonharmonic cycles do not really exist, since, unless they are harmonic, their existence would soon come to an end by starvation.

In the market, at least, all cycles must “feed” (get their values) from a single source—transactions in the striking zone. Since there is only one striking zone in the market—if we consider the market as a unit—there is no way for a 225-week cycle to “feed” except along the sine value vectors which are common to all harmonic cycles. An unharmonic cycle, then, would “starve” out of existence in a short while, just as some pigs in a big litter starve when there are more piglets than teats on the sow.

In Table 3.1, we can also see another characteristic of harmonic cycles. If they are whole multiples of each other, they are closely related. For instance, all of the values in the 25-week cycle can be linked to the same values in the 75-week cycle and also to the 225-week cycle, since each of the larger cycles is three times larger than its predecessor.

If the cycles are fractional relatives, however, only part of the values of a small cycle will find a linkup in the larger cycle. For instance, there are only three harmonic links between the 10-week cycle and the 25-week cycle. Two of the values in the 10-week cycle are not duplicated in the 25-week cycle, so the two cycles resemble two children of the same mother from different fathers. They are related, but not so closely as two children with the same mother and father.

Earlier, we pointed out that cycles build from a series of thrusts (and recoils),



and, if we assume that all small cycle thrusts are small, we can see that a series of thrusts with strengths of from, say, zero to 1, will carry all of the sine values and all of the harmonics as it slides through the range. In the synthesis, we carried only part of the harmonic range since we adopted a one-week interval for our spacing. Between the five values shown for the 10-week cycle, then, there are actually 20 more on a daily basis and innumerable more on a “sliding” basis. Each thrust of a small cycle, sends out all, or at least most, of the vector values as it builds from a trough.

We can see, then, that each of the larger cycles receives a large quantity of harmonic values from each thrust, and the larger the cycle gets, the more harmonics it will contain.

The harmonic vectors which a small cycle sets up as it reacts to a thrust will find harmonic “receivers” in the large cycles so that the large cycles’ strength results from a series of thrusts of the small cycles. This is especially true if we consider that each large cycle consists of a quantity of small cycles, or that the large cycle is really a multiple of the little cycles.

Big cycles build because their “receivers” are a half-phase out of “sync”

Now, as we can see most easily in the case of the 10-week cycle, the sine values are really representatives of whatever values we wish to include in the moving totals with which we measure cycles—more about this later. That is, the sine values, which are the relationship between the vertical side of our triangles and the hypotenuse, are dependent for size upon the angle involved, since it is the angle which determines the value of the sine, and we just saw that volume is the principal factor in determining the angle involved in the vectors which cross the cyclical field.

Since it is volume that determines the speed of travel of price, in most cases, we can determine the vector angle by the relationship between volume and price. Since this relationship is in concrete terms, the sine values really indicate what happened to the relationship of the basic values—or the sine values in Table 3.1 for the 10-week cycle really represent the buildup and decline of price and volume. If the sine values were real numbers instead of a ratio, we can see that a cycle would build from zero to 3090, to 5878, etc., and, on the decline, would reverse and come back down from 10,000 to 9511, to 8090, etc.

Long cycles, as we said, are really multiples of small cycles. For instance, there would be $37\frac{1}{2}$ two-week cycles in a 75-week cycle if it were perfectly regular and there would be $12\frac{1}{2}$ two-week cycles in the 25-week cycle.

Now these halves are important. That is, for a large cycle to build, its “receivers” must be a half-phase off synchronization with the small cycle from which it receives its values. In the 10-week cycle, there are five values upward in half the cyclical swing. If the 25-week cycle were in perfect synchronization with this swing, the new figures of 3090 and 5878 would be the exact equal of those already in the moving total and nothing would happen. When the large cycle is out of synchronization by half a small cycle, however, the zero, 3090 and 5878 values will be matched against the 10,000, 9511 and 8090 of the previous small cycle. The moving total of cycle measurement,



then, will swing in regular waves as small values are matched against large values, and vice-versa as the cycle progresses through time.

This is how small-cycle values in the cyclical field are transmitted to larger cycles, and since we know that vectors have both direction and magnitude, we can see that direction of the transmission is established by the price of a stock or an average, while the magnitude is the result of the quantity of volume which causes price change. Market cycles, then, are the result of price movement and volume.

Vectors also measure the condition of the market

We also pointed out, at the beginning of this discussion, that the vectors of the cyclical field had an additional useful purpose. That is, by considering that the vectors are the hypotenuses of triangles, we can measure the strength of the forces at work building a cycle, and since the number of vectors possible is almost as big as we want to make it—like the number of “center-cut” chops in a slab of pork—we can see that we can deal with any size cycle by this method.

To do this, we need merely to establish the value of the forces at work in the market and, assuming that they are really working at right angles or together produce a right-angle result, we see that, if we consider one of the values or side of a triangle as price and the other as volume, we have a two-dimensional yardstick with which to measure the market.

Most market movements are judged from a single criterion—a yardstick of price such as the Dow industrial average or the Standard & Poor’s 425 or the exchange indexes. The Dow, of course, is simply an average adjusted for stock splits and dividends over the years, while the others are averages with “weights” or added values built in for various purposes. Regardless of the care of composition, however, they remain one-dimensional yardsticks of performance.

Now since we know that there are at least two forces in the market and that the result of their opposition is two-dimensional, it follows that we are going to get a lot better result if we measure a two-dimensional thrust and recoil with a two-dimensional yardstick. This is exactly what vectors are all about. That is, the direction or angle of the vector is established by price movement, and the magnitude of the movement is established by volume. Price alone is of little help in establishing market condition, but when price is added to volume, the measurement becomes much more exact. An asking price, as we said, can be any figure. It only becomes meaningful when somebody pays the asking price.

Vectors, then, have value as a two-dimensional yardstick with which to measure a cyclical movement. If you want to “see for yourself,” contrast the difference of “feel” you get when you look only at the lefthand price scale of Fig. 2.1 in contrast with the reassurance involved when you couple this measurement with the vectors. If you start at the first timespan, or vertical line, and watch the progress of the cycle up to the center of the figure and down to the end, you are in a much better position than if you simply see the cycle as vertical measurements along the price scale.



III—Cycles and the Random Walk, or, the Effect of Randoms and Seasonals on Cycles

There are basically three theories about how prices move in the market. They are: (1) the technical analysis theory of repetition, which holds that patterns of price movement that have occurred in the past will repeat themselves; (2) the fundamental analysis theory of intrinsic value, which holds that stocks have value which is based on earnings and/or future dividends, and thus establish a stock's future "worth" and (3) the theory of random walk, which, essentially, says that since the other two don't work well, the market must be random, and, hence, is unpredictable. The random walk theory, in turn, has led to the development of the beta factor, or a measure of the risk involved if the movements of the market are, indeed, random movements.

The trouble with the technical analysis theory is primarily that it can't be made to work over long enough periods. That is, while short-term patterns do appear to repeat, the longer the pattern in time the less likelihood there is of repetition. The most advanced technical analyst of his time, the late R. N. Elliott, found that his work was best suited to (1) an average of stocks instead of individuals and (2) short-term movements, since the long-range patterns which Elliott developed became extremely complicated.

The principal trouble with fundamental analysis is primarily that it doesn't work all the time. At the beginning of a bull market, the response of stocks to earnings is fast and furious since everyone wants to buy. At the end of a bull market, nobody pays much attention to increasing earnings, or even to increased dividends, since they seem to be more or less expected. A slowing of the rate of growth of earnings, however, can have disastrous results on a stock's price, which is why price is especially vulnerable near a market peak and why some stocks top out early.

Now we said that the trouble with technical and fundamental analysis was "primarily . . ." That is, both of them have value or they would have long ago disappeared, and, fortunately, both can be incorporated into cyclical analysis because both add to cyclical interpretation, particularly in the field of individual issues. A "dog" of a stock will do little in a cyclical upswing, a "good" stock will do well.

In this section, let us take a look at the effect of randoms and seasonal patterns on cyclical swings. The seasonals are important, the randoms have little more than short-term effect.

Cyclical analysis can assimilate technical, fundamental and risk-factor analysis

None of the three theories has been proven completely wrong but neither has any of them been proven completely right. The reason is that all of them disregard cyclical influence, with the possible exception of technical analysis, which means, to a cyclical analyst, that they are attempting to build a house without a foundation.



The point is that time is an element which cannot be disregarded because timing is the major factor in stock profits. The cardinal and indisputable rule of the market is “buy low, sell high,” and this is the basis of cycles: They start from a trough, run to a peak and descend to a second trough in specific timeperiods.

Cyclical analysis has no dispute with any of the three theories, and, in fact, embraces the good in all of them. There is no doubt that many of the patterns technicians see in stock charts are basically cyclical in nature. There is also no doubt that a stock with good and/or improving earnings will do better as an investment vehicle than one with bad or declining earnings. There is also no doubt that stocks can move randomly—or in opposition to cyclical influence—at certain times, even though their tendency over a long run is to move with the cyclical influence.

The problem, then, is not which theory is the best, but to assimilate the good points of all three theories into the overall cyclical theory which can explain the deviations of all three from an expected norm.

Now cycles, we are the first to admit, are not perfect in performance either. Like everything else their movements must be considered in relation to what we expect, but, overall, stocks will move in consonance with cycles, as we shall see.

The basic reason this is true is that a cycle, of whatever length, is really a representation of the average stock of the market. That is, measurement of cyclical influence results in striking an average or finding a representation of what the average stock is doing, just as actuaries find the average man or woman. When you work with an average, of course, the average is composed of stocks which are doing better than the average and stocks which are doing worse than the average. When a stock is doing better, it is usually because of better fundamentals, and it may also be because of a “story” which is evident in a chart. In addition, certain stocks will resist an upward cyclical pull while others will resist a downward pull, for reasons of their own.

Cycles are often difficult to explain because cycles come in a myriad of lengths. As a result some are going up and some are going down at the same time, but, at a true cyclical bottom, when all of the cycles get back into synchronization of timing, the “randomness” of the market mostly disappears, so that measures made from a major cyclical trough to a second major cyclical trough yield results which are very different than those derived from other timeperiods.

The “randomness” to which we refer is not blind wandering but actually occurs mostly in response to the pull of individual cycles rather than a chord of cycles. That is, the 10-week cycle, five weeks up from a previous trough, will be pulling down—against the upward pull of the 25-week cycle. The movement of a stock may then appear to be random, even though it is not and comes in response to the short cycle.

In addition to this cyclical-pull “randomness” of prices, there are the true randoms which are generated by unexpected news events—generally a change in someone-of-influence’s position—and which are usually considered to be capable of sending shock waves through the market, greatly affecting stock prices. The fact is, however, that only news events which are of sufficient import to be long-term or trendular in nature will cause more than a short-cycle reaction, as we shall see.



How the cyclical field contains and tames random events

The best way to test a theory is to see how it has performed in the past, and then see how it performs in the future. This is impossible in a book, since a book can never be more than historical in its examples. However, if we can see repeated illustrations of the working of a theory, we can assume that it will repeat in the future as it did in the past—and, if we are sufficiently motivated, we can check its performance for ourselves.

To begin our test of the cyclical theory, let us see how some news events have affected the Dow average. That is, if a response to a random can be expected, it certainly ought to show up in a small average like the Dow. And, if we can assess the effect of a random in the past, we can also assess the likely effect of a future random.

To start with, we say again, cycles are actually affected only by randoms of a trendular nature. That is, while the shock may affect a short cycle greatly, the real test is what it did to longer cycles, and, in most cases, the longer cycles remain unaffected. The reason for this is that aspects of the cyclical system are like a gyroscope since the system offers considerable resistance to any force which tries to change its direction. That is, when the cyclical wheels are spinning in an upward movement, cycles tend to continue upward and stabilize price movements, just as a gyroscope stabilizes a ship against wave action.

The stabilizing influence of cycles arises from the linkage of harmonic values along the lines of the vectors of the cyclical field. As these vectors stretch outward across the field from the striking zone, they “tie up” with harmonics in the pricebands which arch across the field. The combination of harmonic pricebands and harmonic vectors forms a network of influence throughout the field. When a random event of some importance occurs, unless it is of sufficient force to change the basis of the larger cycles, the network of harmonics contains the random and stabilizes the shock waves which the random causes. That is, a rapid change of price of a stock (or stocks) in response to news, sets off a reaction from the cyclical field which tends to offset the response. If a stock drops rapidly, there are always traders present who will buy because the price is lower. If a stock rises rapidly, there are always traders who will sell (or sell short) because of the price increase. Anything that appears to offer a good buy or sell opportunity immediately strikes a responsive chord in someone in the cyclical field, and volume flows from the field almost immediately.

For instance, in Figs. 1.1, 1.2 and 1.5, we illustrated what happened to Occidental Petroleum, Fairchild Camera and the DJI average on Monday, November 20, 1967. On the previous Saturday, when the markets were closed, the British pound was devalued from \$2.80 to \$2.40. This was a true random and a disturbing force in the market on Monday, since the devaluation announcement was kept so secret that even the Bank of England, which was supporting the pound at the old price during the Thursday and Friday markets, did not know of the devaluation and wasted millions of dollars in support of the old price.

When the market opened on Monday, a devaluation-inspired selling wave hit the market, and both OXY and FCI opened considerably lower than they closed on



Friday. By about noon, however, both stocks had reached levels approaching the Friday close. The network of cyclical forces contained the random and returned prices to a reasonable level in short order. An upward market shrugs off bad news because the cyclical force is pulling upward.

In cases like this, the effect of a random event on the cyclical field can be said to resemble what happens when a block of wood is dropped into water. The gravitational force of the block carries it beneath the surface of the water until the gravity is overcome by the buoyancy of the wood—at which point the block will return to the surface. Dropping prices into the elastic cyclical network causes a reaction to the disturbance in the network, and the reaction carries prices back to a reasonable level. At all times the forces of the cyclical field must remain equal and opposite, so that an excess of one force requires a reaction by the other. A wave of selling generates a wave of buying. The reaction of the cycles, as in our example of a block of wood, is dependent on the quantity of the block which is dropped. If it is small, only small waves will be generated. If it is large, larger waves will arise—but hardly any of them will cause any effect at the shoreline, except in a barrel.

A similar random effect which transpired over a much more extended period is illustrated in Fig. 3.5, which shows the May, 1970 drop of the Dow average to the 628 level. This dip was caused, according to newspaper accounts of the time, by the forced selling from bank and margin accounts to bring equity values of the accounts into a better relationship with indebtedness. The result of the forced selling was that the DJI dropped below its cyclical bottom zone of about 675 and continued downward to a low of 628. As soon as the forced selling stopped, however, prices returned swiftly to the 675–725 level—as the cyclical forces regained their balance—since the margin calls did not represent a fundamental change in the basis of the market.

The elasticity of volume quantity contains the randoms

When random events such as those we have described hit the market, it is volume that takes up the slack of the cyclical network, since volume is the only elastic force in the market. Prices, of course, get larger and smaller, but they do not expand and contract since they are only reflecting the cost of buying a stock. Volume, however, does expand and contract in quantity, and this allows the balance between buying volume and selling volume to react when a random causes a selloff of prices in the market. When selling volume suddenly increases, the imbalance with buying volume can carry only so far until the attractiveness of price induces an increase in buying volume. When this occurs, the market reacts upward until prices again reflect a balance of desire between buyer and seller—or until the block of wood surfaces.

The opposite happens when a good-news random hits the market. In Fig. 3.6, we can see the surges of volume which greeted two news events on two days running. For contrast, we show normal days for the period, before and after the news events. On July 22, 1970, a Viet-Cong minister was quoted from India as saying she favored a broad-based coalition government in South Vietnam and that the coalition could include some members of the South Vietnam government. At this point, the market,



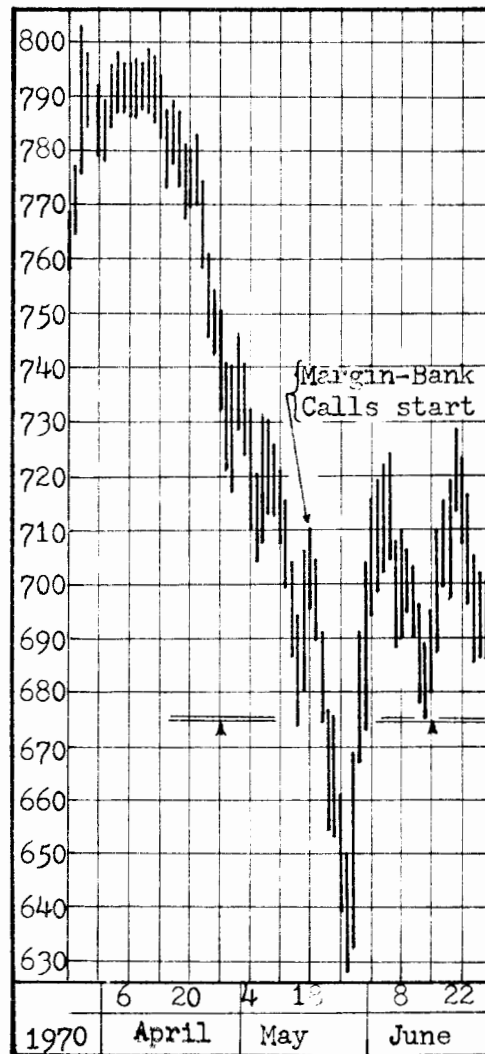

Fig. 3.5—The “randoms” of bank and broker margin calls carried the Dow average to new lows in May, 1970 from which it quickly recovered.

having declined for 19 months and down about 11 points from the July 21 high, was in the mood for any kind of peace news. The report appeared on the wires at 11:58 a.m. EDT. At noon that day, the DJI was calculated at 721.18 and volume between 11 and 12 o'clock was 2.64 million shares.

When the news appeared, a wave of buying hit the market—and from 12 to 1 there were 4.37 million shares traded. At 1 p.m., the DJI was at 730.97—up 9.79 points in an hour. At 1:31 p.m., the wire service reported: “Mme Binh’s statement was hardly new—the Viet-Cong original peace proposal called for a coalition government.” The bubble was broken, and at 2 p.m. the DJI had retreated to 727.41 and

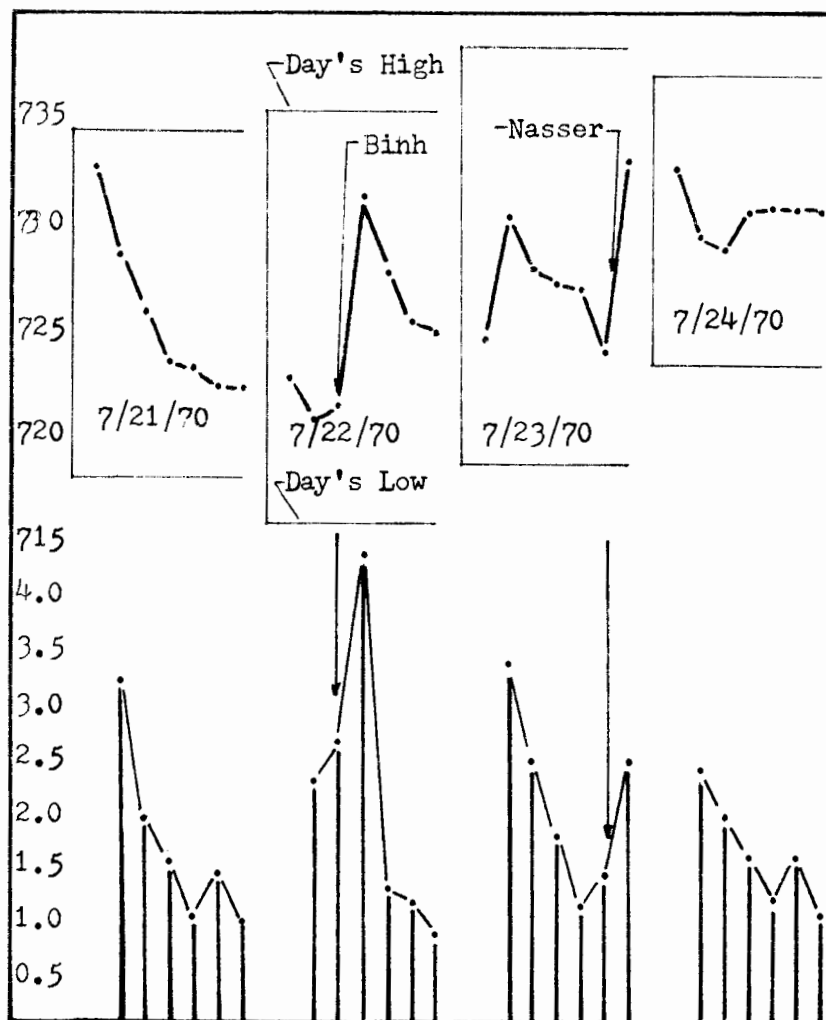

Fig. 3.6—The effect on volume and price of the Dow average of two "randoms" of peace news in 1970.

volume to 1.25 million during the preceding hour. At 3 p.m., the DJI was 725.15 and hourly volume was 1.12 million. At the close, the DJI read 724.67 and volume in the half hour was 0.83 million shares.

On July 23, 1970, a similar event occurred. Shortly after 3 p.m. EDT, the wires reported that President Nasser had said Egypt would approve and accept U.S. proposals for peace in the Middle East. The market at 3 p.m. was at 723.71 and volume from 2 to 3 p.m. was only 1.38 million shares. At the close, the DJI was at 732.68—up 8.97 points in half an hour, and volume spurted to 2.46 million shares in the same time.

The biggest random of all in recent years, however, was the bombshell announcement on a weekend in August 1971, when President Nixon announced his new economics



policy and shattered existing monetary arrangements. The market opened on Monday, August 16, at a Dow average price of 897.49—up 41.47 points—and continued the climb to a high of 906.32, closing for the day at 888.95, up 27.37 points.

That this random was also a true random is indicated in Fig. 4.7 which shows an 18.18-point gap between the Friday high and the Monday low of the Dow average. Gaps in the average, incidentally, are very rare, even small ones.

After this start, the market continued to climb until early September when it reached a high of 925.67, but, from this peak, the market resumed the downswing of the 78-week cycle, which started in April and continued to a low at Thanksgiving when the 78-week cycle troughed. From this trough, the market again started a climb back to and beyond the April 1971 high.

From this example, we can see empirically that the effect of the random caused a sharp reaction upward—which continued for five weeks, or half the 10-week cycle length, and then resumed the direction indicated by the decline of the 78-week cycle. That is, the effect of the 78-week cycle overcame the effect of the random and its effect on the short cycles, so that as soon as the 10-week cycle had adjusted, the 78-week cycle again became dominant enough to drive the Dow average down to a low below 800—from the nearly 960 peak it reached in April 1971.

The seasonal pattern in average monthly volume

Volume, in addition to expanding and contracting to get cyclical forces back into equilibrium, and in addition to having cyclical characteristics of its own, also has seasonal patterns. For instance, in Fig. 3.7, we illustrate monthly volume in the market in the 68 years from 1898 to 1966. The chart of Fig. 3.7 shows volume for each month as a percentage of the monthly average volume for each of the 68 years. The dotted line on the chart represents the combined percentages of the four 17-year cycles which are involved in the period. For instance, the first value for January is the sum of the percentage of each of the cycles: from 1898 to 1915, January accounted for 100.40% of each year's volume average; from 1915 to 1932, January volume was 106.12% greater than the average monthly volume; from 1932 to 1949, January volume was 107.96% greater than average and from 1949 to 1966, January volume was 113.08% greater than average. The sum of the percentages equals 106.89 (right-hand scale) for all 68 years. In the chart 100 equals average monthly volume, and the values above and below 100 show the deviations by month of volume totals.

From the chart, we find that January is a high-volume month—106.89% more than average—and that February is a weak month for volume, with the figure at 98.7%. March, April, May and June are also above-average months, but July, August, September and October are weak months. The low points in the pattern are February and August. These are the months when fewer decisions are translated into a market transaction.

The dashed line in the chart is the average monthly closing price, also expressed as a percentage of the average price for each month in the series. For instance, in January prices are 100.41% higher than average, and they reach a peak in April at 101.38%. We can also see that the high for the year is established in April and the low

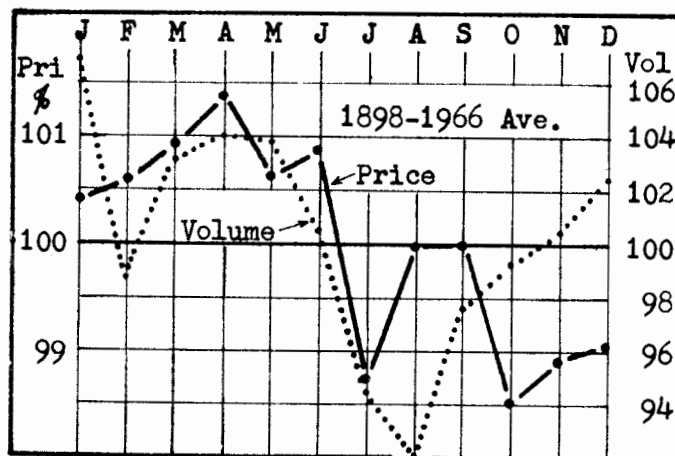

Fig. 3.7—Volume and price expressed as a percentage of 68-year monthly averages.

for the year occurs in October, with a secondary trough in July of each year—on average.

Why market crashes hit bottom in July and October

We also note in the chart that the price curve and the volume curves are closely related—or closely correlated—during six months of the year, but the correlation breaks down in the latter half. In other words, there is a close relationship between price movements and volume movements from February through July, but in the other months the indicators are sometimes going in opposite directions. For instance, in February, volume is declining but prices are going up, on average. In August, the same situation exists. In September, prices remain steady but volume increases, and in October, prices decline while volume is increasing. In November and December, the relation of price to volume, while positive, lacks in proportion.

When we stop to think about this apparent discrepancy, the first thought that should enter our minds is that volume is two-headed—buying volume and selling volume—in addition to expanding and contracting in total amount. For instance, in February, while total volume is declining from the January figure, prices continue upward, because more people are buying than selling stock in February. In July, price has reached a low and prices rebound, despite the continuing volume decrease in the month, which continues until August. During July, then, prices are rebounding from their July low but are doing so on decreasing volume, and in August prices are steady while volume continues to decline.

Midsummer rallies, thus, are suspect, since the relation of price to volume is weak—prices increase while volume decreases. October, of course, is an habitually weak month for prices, but volume continues upward during the month. What happens? More people sell stock than buy stock in October. The reason, probably, is that, with



the approaching year's end, people decide at this time which stocks they "want out of" and which stocks they want to buy. The selling comes first, to raise cash to buy, so that after the October selloff, prices start to rise as buying assumes the ascendancy. The same thing, probably, occurs at the June-July lows, which occur about the time the six-months reports are due. After these two lows the market regains equilibrium as to price, and prices begin again to respond to the normal price-volume relationship.

From Fig. 3.7, then, we can see the reasons why the market acts the way it does at certain times of the year—why the 1957 bottom came in October, why the 1962 crash ended in June and why the 1966 crash ended in October. June-July represents a market falling because of decreasing volume, and September-October represents a market falling because of increasing volume.

The reason why the "summer rally" has disappeared

We notice in Fig. 3.7, that price hits a low in July but volume continues downward to a low in August. This wasn't always so. That is, in Fig. 3.8 we see a chart in which each of the four 17-year cycle periods is broken out separately. At the top of the chart, we can see that from 1898–1915, there was a very close correlation between price and volume. When volume dipped, prices dipped. When volume increased, prices increased. In those days, price and volume tended to move upward from the February low to peaks in April and June, but in July prices again moved downward in response to declining volume. For the year as a whole, prices tended to increase from February to June and decline the rest of the year, with lows in July and again in October.

This pattern changed somewhat in the years from World War I to the 1932 low. Prices went up from December to March highs, and then declined to a June low. Volume hit a peak in March and declined to July. Prices in these years were again strong in July, August and September and volume accompanied the rise in the latter two months. As we see, by sneaking a glance prematurely at the remaining two charts, this period in the market gave rise to the now ephemeral "summer rally" theory on which hope hangs during the summer months. Unfortunately, a real summer rally has not been present strongly enough to show in a market average since 1932, proving people have long memories. It is interesting to note that much of today's market "lore" actually reflects lessons taught in the rise to the 1929 high. In the 1920s, as in the 1960s, a market writer had a large ready-made audience of eager listeners.

If we look again at Fig. 2.4, we can see that during the third 17-year cycle from 1932–1949, prices tended to remain pretty level, in contrast with the previous cycles. That is, the DJI average tended during this period to oscillate between a high of about 200 and lows of about 110. The result of this is apparent in the monthly average price pattern for the period during the 1932–49 cycle. In this period, about the only thing that moved was volume. Here, again, volume hit a low in February but the summer low moved from July, as in the previous periods, to August. Part of the reason for the lows may be due to weather, since February is a generally ghastly winter month and August is a generally ghastly summer month, but at any rate, volume figures show a positive and large drop in February and August during the period.

In the final cycle, which is illustrated in the chart, we see that the volume low



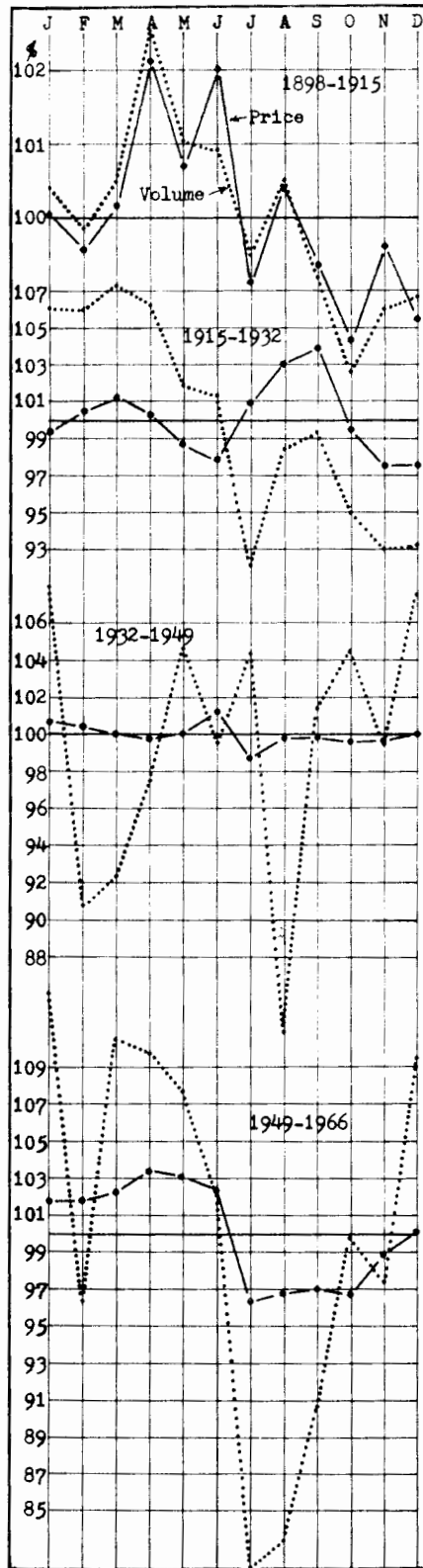

Fig. 3.8—Price and volume averages by month in each of four 17-year cycle periods.

has again shifted back to July—but August is also a very slow month insofar as volume is concerned. The result is that both July and August are weak for volume. Prices reflect this shift of volume. For instance, prices on the average drop from a June figure of 102.34% to a 96.28% figure in July. From July to October, prices continue at very much the same level with no appreciable increase until November and December, even though volume increases markedly from August to October. We can consider, then, that during the summer months, more people are selling stock than buying, and fewer and fewer of them are doing either buying or selling during July and August than at any other time of the year. By September, however, with vacations over, people come back to the market and make readjustments of their portfolios. When this selling and buying is completed, prices and volume again continue upward.

Why the sixth month is the toughest in the tax-holding period

Now, will you please take another look at all four of the cyclical periods in Fig. 3.8? We see that volume troughs in February in all four periods and troughs again in July–August, and that, in general, the price pattern is broken into two six-month patterns during the year. The first half of the year exhibits prices which are higher than the average for the year and the second half of the year exhibits prices which are generally weaker, except for 1915–1932.

As we know from Chapter 1, there is a cycle of about 25 weeks length in the market. This price cycle is responding to fluctuations of volume on a seasonal basis. Volume is above average during the first six months, with the exception of February, and is below average during the latter half of the year. The six-month cycle thus tends to extend from February–March to July–August and again from July–August to February–March. Prices tend to follow the volume curves, with weakness in February–March, July–August and October–November. If you examine the monthly charts, Figs. 2.2–2.5, you can see that this pattern tends to be followed in most years during the entire stretch. The 25-week cycle, then, is the reason long-term “investors,” who have to wait for more than six months for tax reasons, find that the sixth month of their wait is worse than all the preceding months. To profit from the 25-week cycle, which is just a week short of the holding period, the long-term “tax investor” has to wait for nine months to get the full potential of the 25-week cycle.



TORQUE Analysis of Stock Market Cycles 4

The systems from which cycles derive are completely balanced affairs—not only in their overall dimensions, but also in their details—and the balance is maintained by movement. For every force within the cyclical system, there is an equal and opposed force which moves to counter a thrust or a recoil, and returns the balance to equilibrium.

It is really movement, then, which keeps the system in balance, with an original movement from within the circumference of a system and a resulting movement which arises when the balance is thrown off-center, and, as we saw in Chapter 3, it is only movement from within the circumference of a cycle which causes lasting effects. Extraneous events affect the system only as it may react to the purport of an event.

I—The Basis for TORQUE Analysis Is That Price Is a Liar

The cycles we see in the market are not the movements within the system but the derivatory effects which build up as a result of the movements within the system.

As an example, if you mount two steps at a time and move back one, you are generating the upward swing of a “cycle,” and, eventually, when you reach the top of the staircase, if you reverse your motion you will start on the downward swing and complete the “cycle.” If we imagine the top of the staircase as an asymptote or upward limit of cyclical swing and the bottom of the stair as the lower asymptote, we have a pretty good idea of the one-dimensional moves of a cycle.

Now, if it were dark while you were running up and down the stairs, you might not be seen by an observer, and if you carried a flashlight in your



hand, the observer would be likely to see only the movement of the light and might get some pretty wild ideas of what was going on. Especially if the stairs were at the top of a haunted house in which nobody lived. Prices in the market are like a disembodied flashlight. The first thing you see in a stock price chart is price movement, and, only if you look carefully, bars which represent volume. But prices, as we know, are merely third-dimensional effects which derive from an underlying system.

The important thing in the market, then, is not the price patterns which a chart may develop, or whether the price represents a 10- or a 40-times price earnings ratio, but who is carrying the flashlight? We know it is the cycles which do the carrying, but, like the "ghost" in the haunted house, cycles are also derivatory from something else. Who told the man to carry the light?

TORQUE analysis of stock market cycles, as we shall see, answers not only the first question of who is doing the carrying (the cycles, of course) but also the second of who told the man (volume).

TORQUE analysis shows cycles as the yield from underlying balances

TORQUE analysis treats price as the visually apparent part of a cycle and deals basically with the underlying equation—buying and selling. This automatically puts price and volume into a relationship of reality. When prices move, there must be a corresponding movement of volume, just like the related movements of the radius of thrust and the radius of growth, because price without volume is meaningless.

Like we said earlier, cycles are intangibles and they can only be visualized statistically. To understand them, we must find a statistical method which will show cycle performance as the yield from the changing balances between the forces which cause the cycles. That is, if we are to understand the market's cyclical system, we must be able to break up the system into its components and then recombine them in a mathematical formula which will yield the actualities of cycles to compare with price—or, in our case, the Dow industrial average for a starter.

If we can understand the design of each part and describe its relationship to the other parts of the system, then we shall have a decent chance of predicting what is likely to occur in the future and when it is likely to occur—which is, of course, the heart of any prediction.

To start with, we know the cyclical system converts volume into market price movements, just as gasoline is converted into travel by an automobile engine, since price undulates along cyclical paths which are determined by the quantity of transactions and the relationship of buying to selling volume. That is, we know: (1) When volume increases in quantity, the price of the DJI has a tendency to rise, and, when volume declines, price has a tendency to decline. (2) Even when volume is constant in quantity there is still a tendency for prices to rise and fall. (3) The fluctuations of price have a tendency to follow a path which we can closely describe by combining five harmonic-length cycles into a synthesis, as we did in Chapter 1.

To understand the cyclical system of the market, then, we must be able to measure accurately whole volume's effect as an entity, measure the balance between buying and selling volume and their effect on price movements and, from these essentials, measure the undulations of the separate and combined price cycles, finally finding a means of



describing trend (which we see as long-term cycle movements) as well as the extremely short movements. Cycles provide the reason for the rise and fall of prices, volume provides the motive power of the movement and cyclical trend establishes the direction of the overall movement—up, down or sideways.

The formula for TORQUE analysis of cyclical strength

Earlier we likened cycles to an automobile wheel. An auto wheel is turned by the thrust of an engine but price cycles in the market are turned by the thrust of volume. Instead of being transmitted through an axle, however, the motive power of volume is applied against a point on the circumference of a cycle, so that the net effective force of volume gives a cycle a “push” to make it revolve. For instance, when a mechanic wants to move an automobile wheel that is off a car, he pushes against the surface of the tire in the direction he wants it to go. The force which the mechanic uses to push the tire is applied on the surface of the tire or tangentially to a point on the circumference. Since this is the only way a tangential force can be applied, the direction of the force on the surface is at a right angle to the radius of the wheel.

Now a right-angle relationship between a force and a radius is a measurable force, known to engineers as mechanical torque. Torque sounds complicated but it really isn't. If you try to open a screwtop bottle and can't do it, you get a pair of pliers and the top comes off. You have applied more torque (or twisting force) by increasing the radius of the screwtop by the length of the pliers so that the same force, or less, will unscrew the cap. The net amount of force which you apply can be measured by multiplying the pounds of pressure by the length of the radius of the pliers. For instance, if the length of the plier radius is 6 inches (or 0.50 feet) and you have applied 20 pounds of pressure on this radius, the torque factor, or the net pressure applied at a right angle, is 10 foot-pounds. That is: Torque = Force × Radius. Since we know that from this sort of algebraic equation we can determine any of the three parts from the other two, we also know that the torque factor divided by the force equals the radius, or:

$$\frac{\text{Torque}}{\text{Force}} = \text{Radius.}$$

If we substitute cyclical terms for mechanical terms in the equation, we have price for torque, volume for force and cycle for radius. That is, we know that price is a result of the pressures of cycle and volume, we know that volume is the force which moves price cycles and we also know that cycle and radius are identical. Our equation now reads $\frac{\text{Price}}{\text{Volume}} = \text{Cycle}$ —or, the net movement of price divided by the net amount of volume equals the cyclical strength factor. Since we can easily establish price movement in the market and since we can calculate the net upward or downward pressure of volume, we can then arrive at a factor for cyclical strength. This method of analyzing cycles, we have labelled TORQUE analysis.

TORQUE analysis of cycles measures underlying forces, not prices

TORQUE analysis differs from other methods of measuring cycles because the TORQUE method recognizes that price in the market is not genuine unless it is the result of underlying forces. The first of these forces is volume, which is the force prin-



cipally involved in the movement of price, and, second, is the cyclical influence which determines when price will move and how long price will rise before it begins a decline. That is, a cycle in the market is a power which causes price to undulate in rhythmic fashion. It is an inclination toward price movement which arises because the relationship between buying and selling volume alternates at regular intervals of time. In other words, cycles are a rhythmic influence in the movement of stock prices—a power which can be seen and measured—when price and volume are coupled mathematically.

The usual method of measuring cyclical force is the measurement of the deviation of price from a moving average, or any type of trendline. That is, the swing of prices in the market does tend to center around a trendline, if it is properly applied, and a reasonable measure of the (vertical) amplitude of movement of price can be obtained by measuring the deviations from trend. The faults of this method, however, are: (1) the measurements are historic, especially if centered, moving average methods are used, and cannot be brought up-to-date; (2) there is *only an assumption* that price peaks and troughs mark cyclical peaks and troughs; (3) there is no method of forecasting except by technical study of past movements and the further assumption that past patterns of price will repeat and (4) the method strongly implies that cyclical radii are complete variables, which is untrue.

With the TORQUE analysis method, these faults are eliminated: (1) measurements can be brought up to the minute; (2) the movements of cyclical force can be measured accurately from underlying causes, so that we are no longer entirely dependent on price swings; (3) prediction of probabilities derives from intimate knowledge of the underlying forces which, when combined with fundamental and technical methods of stock analysis, allow us to arrive at a good conclusion as to the future movement of price and (4) since we are measuring actual cyclical strengths with the TORQUE method, we can also extend our measurements to individual stocks which are moving in consonance with the cycles.

Two cycle radii do not always equal a cycle diameter

Earlier, we pointed out that the only thing which changed between the three hypothetical cycles in Fig. 3.1 was the speed of revolution. What we did not point out is that the only thing which did not change was the radius of the cycles. That is, despite the lengthening of the time period in cycles 2 and 3, the radius of the cycles in all cases of the example remained static or did not change in length.

This is an important point because, when we know that cycle radii are limited variables, we learn an important law in cycle structure: The cycle relationships of radius and diameter differ from the relationships which exist in a circle in which the radius is always half the diameter. With cycles, radius change is limited, while diameter has a much greater range of variability—or can readily change its relationship to the radius. That is, the radius of a single cycle is determined by the amplitude of swing, but the diameter, or time length of a cycle, varies according to the quantity of buying or selling pressure which exists within the whole cyclical chord structure, rather than in a single cycle itself.

The reason that radii of cycles are limited variables is that, as with the radius-of-



thrust and the radius-of-growth relationship, there is a ratio which encourages a beginning thrust but discourages a continuing thrust, as we saw in Table 2.1. From a low of, say, 1-to-2 to 1-to-1, the length of the radius of thrust grows in large increments, while from 1-to-1 to 2-to-1, the increments are greatly reduced in value.

Diameters of a cycle, however, are not limited by this ratio, except as they inherit values from adjacent cycles, so that the diameter of a cycle is determined by (1) the time length of its own thrust and (2) the pressure of adjacent cycles or, simply, the net amount of pressure generated by a single cycle and its adjacent cycles. A radius, on the other hand, is determined by the maximum effect reached by a thrust.

This is another reason that measuring cycles by price swing is an unrealistic approach, no matter how precise. It is also a reason that it is difficult, if not impossible, to track a single cycle visually. The cycle is working and doing its best to trough on time but its efforts are handicapped by its relation to other cycles. A single cycle version, then, should be measured vertically, or along the line of thrust, and not horizontally, or along the time axis.

Opposed forces meet head-on but the effect is at a right angle

Besides the basic TORQUE relationship of force and radius, there is also another right-angle relationship which governs forces within the cycle structure. This derives from the 600 B.C. discovery attributed to Thales of Miletus, a retired olive merchant, who found that lines drawn from the opposite ends of the diameter of a circle will always meet at a right angle at any point on the circumference of a circle, regardless of the length of the diameter or the size of the circle. That is, anywhere on the circumference of a circle (or cycle) or a half-circle, the angle between the opposite poles of the diameter is always 90° .

Since we are dealing with the equal but opposite forces of price and the equal but opposite forces of volume, we know that any cyclical relationship between the opposites in the couples is always a right-angle relationship. The opposing forces within a cycle, then, do not oppose each other directly but in a right-angle meeting. When one force is stronger it does not overwhelm its opposite number but causes it to adjust. Buyer and seller in the market do meet in a head-on confrontation, but the effect is an adjustment according to the strengths of each. Price, reflecting the combination of strengths, moves along the circumference of a cycle as an expression of the relative strengths of buyer and seller. In our tomato example, we can imagine price as being the point at which the skin of the tomato ruptures.

In Fig. 4.1, the relationship of price, expressed in advance-decline terms, is illustrated. At 45° , the length of the lines representing advances (the heavy lines) and declines are equal, and, as we learned in Chapter 2, the tangent value of the two forces is 1.0000. Also at equilibrium at 45° is the relationship of radius and force, since 45° also expresses the corner-to-corner bisection of a square. When the A-D relationship changes to $26^\circ/34^\circ$ or to $63^\circ/26^\circ$ —which are both equidistant from 45° —we find that the relationship changes to 1-to-2 or 2-to-1. These limits, $18^\circ/26^\circ$ on either side of the point of equilibrium, establish a practical limit of cyclical swing.

In Fig. 4.2, we can see the whole picture of the relationship between opposed

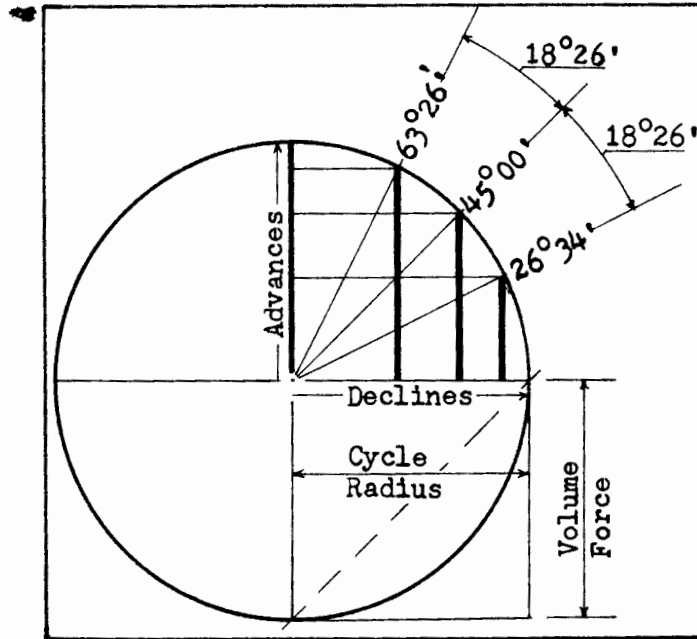

Fig. 4.1—The right-angle relationship of advances to declines and of cycle radius and volume force.

forces of price and volume. When the diameter is tilted so that a 45° radius is at a right angle to the diameter, we still have, at 45° , a balance between the four forces, and, therefore, a balance between cycle and net force. When the relationship changes so that advances have a 2-to-1 majority over declines (at $63^\circ 26'$), we see that the relationship of buying and selling volume has also changed, and also of buying volume to the cycle radius. Also, in the cyclical relationship, price, which condenses to a single value at which a transaction occurs—either an advance or a decline—moves upward or downward when the balance between buying and selling volume changes. That is, when volume is balanced at 45° , price—as illustrated by the black dot on the price scale—is steady at whatever price represents the balance point of the cyclical forces. When volume increases toward the $63^\circ 26'$ limit, however, price moves upward and the advances leg of the equation gets longer. When volume declines toward the $26^\circ 34'$ limit, price and the quantity of advances decreases. Within the timespan diameter of a cycle, then, we can see that stock prices “ride” the cycle circumference, so that price, under the stimulus of volume, can swing upward from the point of equilibrium toward its upper limit, back down toward the lower limit and again back to the point of equilibrium.

By this time, we see that the mechanical system which produces cycles in the market is a relatively simple system of net balance between opposed volume forces working along the circumference of, and at a right angle to, the radius of a cycle. It is also obvious (1) that the movement of a price cycle results from the movement of the



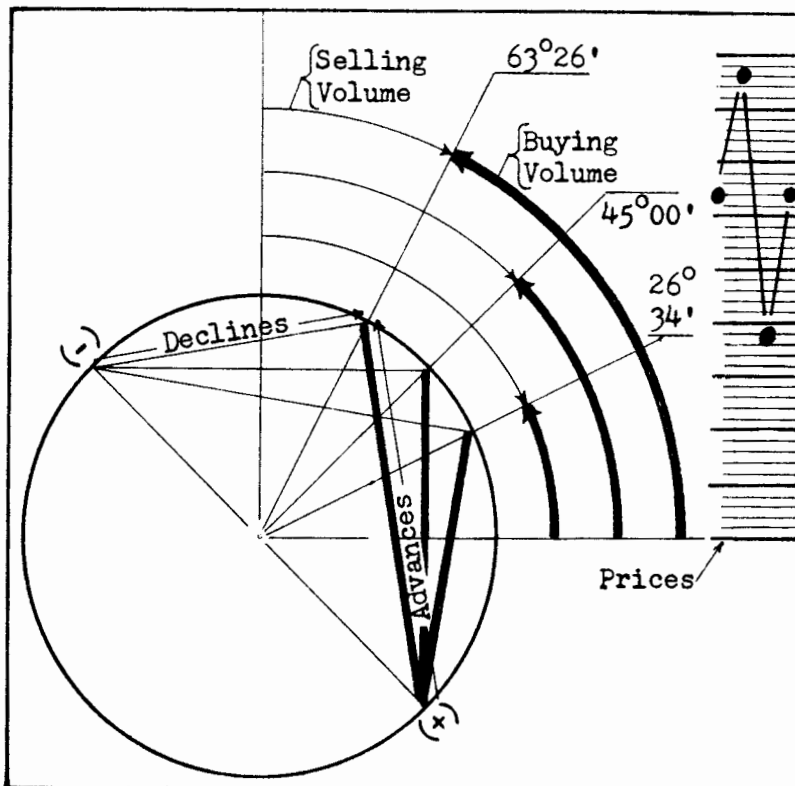

Fig. 4.2—The relationship of the A-Ds, volume and the price cycles of the market. Prices move as volume moves and are reflected on a price scale.

right-angle junction point of the opposed forces of volume as the opposites seek to approach the point of equilibrium and (2) that, just as a clock pendulum swings regularly across an arc from limit to limit, the net balance of force between buying and selling swings back and forth across the 45° point of equilibrium.

II—The Problems of Finding the Basis of Cyclical Forces

When one studies the market over a considerable length of time, many apparent contradictions arise from the observations. At times, one set of observations will be valid, but, at other times, the opposite will appear true since the market is full not only of short-term contradictions but also of seemingly unexplainable long-term considerations. That is, when you try to lay down a set of rules about the market, the list of exceptions gets longer and longer as you observe more and more episodes. Since we know that cycles should swing from low to high to low, and that the downside track of a cycle should be the mirrored reverse of the upward track, it would appear that contradictions must be part of the system. Accordingly, we perhaps can get at the answers by studying the questions themselves.



The principal ones that arise from any perusal of a stock chart are:

(1) Instead of a steady progression in one direction and then in the other, as might be expected from a cyclical performance, stock prices move both upward and downward in a single day, and, simultaneously, upward and downward over longer periods, so that prices are often going in both directions at once. How can we make any cyclical sense out of these erratic-looking price movements?

(2) We have seen that both long- and short-term buildups of volume usually result in an increase in stock prices. At the same time, it is obvious good logic to conclude that there must be a buyer for every seller—else, who is buying the stock? Are price and volume really related?

(3) If, despite our logic, we conclude that there must be more buyers than sellers in an upward market and more sellers than buyers in a downward market, this is vital information in untangling the enigma. Can we determine how much of any given quantity of volume is buying and how much is selling?

(4) When we hunt for cycles in stock charts, we find it hard to determine the length of any of the cycles in the picture. That is, if we are looking for a 10-week cycle, we find that troughs may appear as often as four weeks apart, and sometimes as long as 12 weeks, 13 weeks and even as many as 20 or more weeks apart. In a jungle like this, how can we be sure any rhythms are beating?

How to understand price movement contradictions

When you start to weed a young flowerbed, the first thing to do is separate the flowers from the weed plants, and, when you have eliminated enough weeds, the flowers commence to come into view. The first thing to do in the market is to disregard the closing price, which serves a purpose but also obfuscates the picture we are hunting. That is, what we are looking for is a daily trend, and this we can see if we consider that a stock moves upward only if its high price is higher than yesterday's high and its low price is also higher than yesterday's low, regardless of whether the closing price was up or down. A stock or an average is down, on the other hand, if its high is lower than yesterday's, provided the low is also lower than yesterday's. That is, we know that price moves up and down many times during a day, but if we consider that each longer movement has only one direction, we can easily measure the price movements.

To do this, we start with yesterday's closing price and consider that the average moved only upward from this figure to today's high, and that it also moved only upward from today's low to today's closing price. For the downward side of the movement, we can consider that the average moved straight-line from today's high to today's low price. The difference between today's closing price and yesterday's closing price, then, represents the net movement of the average—or the difference between the upward travel and the downward travel. That is, if the DJI closed yesterday at 900.00, hit a high of 910.00 and a low of 890.00 and closed at 899.00, the Dow average travelled upward 19.00 and downward 20.00 points for a net loss of 1.00 point.

Now the DJI never actually hit the high average price and never touched the low price, since both are calculated prices. We also know that it is most unlikely, even



if the figures were real, that the Dow would make such an orderly progression as upward to the high, down to the low and again up to the closing price. But these small movements are of little consequence in relation to the important thing which we have accomplished—the simplification of price movements into a ratio of “travel” which we can use. That is, we have condensed the intra-day fluctuations into two essential movements—one up and one down—and we know that the two parts are balanced in a 1-to-1 ratio which will deviate only by the net amount of price change from day-to-day, regardless of the total quantity of volume.

Why it is important to separate buying and selling volume

Now let us consider the volume questions, both at once. First, we know that when volume moves upward in a moving total there is a tendency for price to rise. In other words, there must be a relationship between total volume in a stock or average and the price of the stock, and, further, when price is rising it must be because there are more buyers than sellers. When a man is willing to pay a little higher price to get a stock, he is a buyer. When a man is willing to take a little less for his stock, he is a seller. Price movement, then, indicates whether the transactions involved were really sales or purchases, so it becomes obvious when a stock trades on an uptick (usually an eighth higher) that the buyer was more aggressive than the seller, and, when it trades on a downtick, the seller was the more aggressive. From this, we can see that the tick changes of price in the daily trading of a stock are the result of buyers or sellers, and we can also imply that the larger changes of price in a stock are the result of a group of buyers and sellers with the same idea, as opposed to individuals with opposing ideas.

From here it isn't hard to imagine that, when the Dow increases in price, buying is the dominant factor in the market. When the Dow continues to increase day-after-day, it is obvious that more and more buyers are coming to market each day, and when we put the volume figures for a series of days into a moving total, we have another relationship visible. In order for a moving total (or moving average) to increase, the input number must always be higher than the takeaway number. If we have volume figures of 7, 8, 9, 10 and 11 million shares in a five-day total, we know that if today's figure is larger than the 7 million, the total will increase. Also, when the final figure of 11 million comes up as the takeaway number, the total will decrease, unless the new volume figure is more than 11 million. With our moving total, thus, we have a built-in momentum indicator—the moving total can increase only if momentum continues to increase so that the input figures are always larger than the takeaway figures.

Assuming that things are normal so we can expect price to increase as volume increases and decline as volume declines, it is obvious that prices must rise or decline for one of two reasons: (1) volume is increasing or decreasing or (2) the ratio of buyers to sellers is changing, regardless of the volume total. That is, when whole volume is increasing, it is normal for more buyers than sellers to be present in the market. Normally, when whole volume is decreasing, it is because the buyers are decreasing, so that less stock is sold by the sellers. We can't always be sure of this, however, since on certain occasions volume will increase when price is declining and, on others, price will rise while volume is declining.



In any event, we can see that it is important for us to be able to estimate accurately the ratio between buying and selling volume, since this will give us an important insight into what is happening in the market, whether volume is advancing, declining or steady.

How to break volume into buying and selling volume

Now we have already established that we can easily construct a ratio of upward and downward movement for an average such as the Dow. It follows then that by using this ratio, we can break the volume on the NYSE into two parts, since all of the Dow stocks are on the New York exchange. That is, if we multiply the volume on the exchange by the amount of upward travel and divide by the total travel (both upward and downward), we will arrive at a figure which will represent the amount of shares necessary on that day to cause the DJI to move upward by the net amount of upward price movement. Then a simple subtraction of the buying volume from the total volume will establish the selling volume for the day.

This method * of determining the upward and downward travel for the Dow average and the total New York volume is illustrated in Fig. 4.3. On the day in question, the Dow travelled from a previous closing figure of 766.16 to a high of 780.53 and from a low of 763.76 to a close of 776.70—or a total of 27.31 points. The downward travel was from the high of 780.53 to the low of 763.76—or a total of 16.77 points. Since the difference between the upward travel and the downward travel is 10.54 points, and this is the net change of the average that day, we know that our calculations are correct. Volume for the day of the illustration was 19,760,000 shares, so our figure for buying volume was 12,240,000 shares and for selling volume it was 7,520,000.

Before we leave the area of using the Dow to establish the ratio for buying and selling volume, we need to make a point. We use the Dow figure for three reasons: (1) The Dow has a history stretching back to 1897, so we can use the same method regardless of the time period we want to study. (2) The Dow method of determining high and low figures for the day gives full emphasis to the stocks' swings. That is, the Dow daily high and low figures are determined by adding all the high prices and all the low prices together, regardless of what time of day the highs, and also the lows, of each stock were reached. (3) The range figures for the Dow are printed regularly in the newspapers while the broader averages, such as the *Standard & Poor's* and the exchange indexes are often quoted only in closing figures. Besides, although the Dow is often maligned as being incompetent, it shows a very remarkable ability to measure the market's price moves as well as the larger, "more comprehensive" averages. Now please remember that, by considering that there were only two parts to the travel of the Dow—upward and downward movements—we arrived at a 1-to-1 ratio in which

* In the past, a number of market analysts have been concerned with separating volume into its components by various methods. Among the first were Lowry, Lamotte & Whitman, Granville and Williams. In recent years computers have been programmed to give instant readouts. Generally, however, this volume is the volume recorded by stocks advancing vs. stocks declining. Since we use advances and declines to arrive at a price ratio, we prefer to use the travel of the Dow to separate volume for a volume ratio. If we used the A-Ds, we would simply be slicing the same apple in different directions. In any event, except for tick-counting (see pages 131, 133 and 134), all methods are only good approximations.



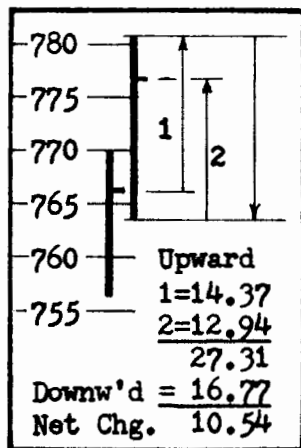

Fig. 4.3—The method of dividing up-and-down "travel" of the Dow industrial average.

one side deviated from the other only by the amount of change in the final prices. By using this ratio to break volume into two portions, we preserve the original 1-to-1 ratio of price and transfer it to the volume figures, so volume also is now in a 1-to-1 ratio. That is, our volume figures now represent exactly the relationship of the price movements of the DJI and will continue to do so. For instance, when there is no movement of the Dow from close to close, the ratio of buying and selling volume will be identical to the price ratio, and also in a complete equilibrium or a 1-to-1 ratio. So, by this method, we can break volume into two portions which are identical with price movement, regardless of the total movement of the Dow's price or the total quantity of volume. In this context, the closing price of the Dow is really insignificant, since it becomes, as it should, only a cutoff point in the continuing movement of price.

Now we can put the separate parts of volume into two moving totals of whatever length we require and the two moving totals will always reflect the overall relation of buying to selling volume for the period. Then, when volume is increasing or decreasing, we can determine from our moving total not only which is the superior force of the moment but also whether that force has sufficient momentum to continue the direction of the price movement which is involved. That is, instead of being dependent upon price movement alone for a judgment of the future, we now can add a second dimension of volume, which not only gives us perspective but also allows us to measure factually the underlying forces of the market. We will know not only how much price moved up or down, but also how valid the price movement was, since we have related it to volume. The desire to buy is one thing but the wherewithal to make the purchase is also important to the transaction.

OXY illustrates the relationships of price and volume

To demonstrate the relationships we have observed in the abstract, we repeat, in Fig. 4.4, part of Fig. 1.1 which showed the movement of the price of Occidental Petroleum stock on November 20, 1967. This time, however, we have added two things:

(1) the volume on each transaction (upward bars if price was on an uptick and downward bars if price was on a downtick) and (2) the cumulative tick-counting totals of buying volume and selling volume, each also being determined by whether the trade was made on an uptick or a downtick. That is, if 100 shares traded when price moved upward, the volume was counted as buying volume and all volume on succeeding trades was also counted as buying—until there was a downtick price movement. The same method determined selling volume in the illustration.

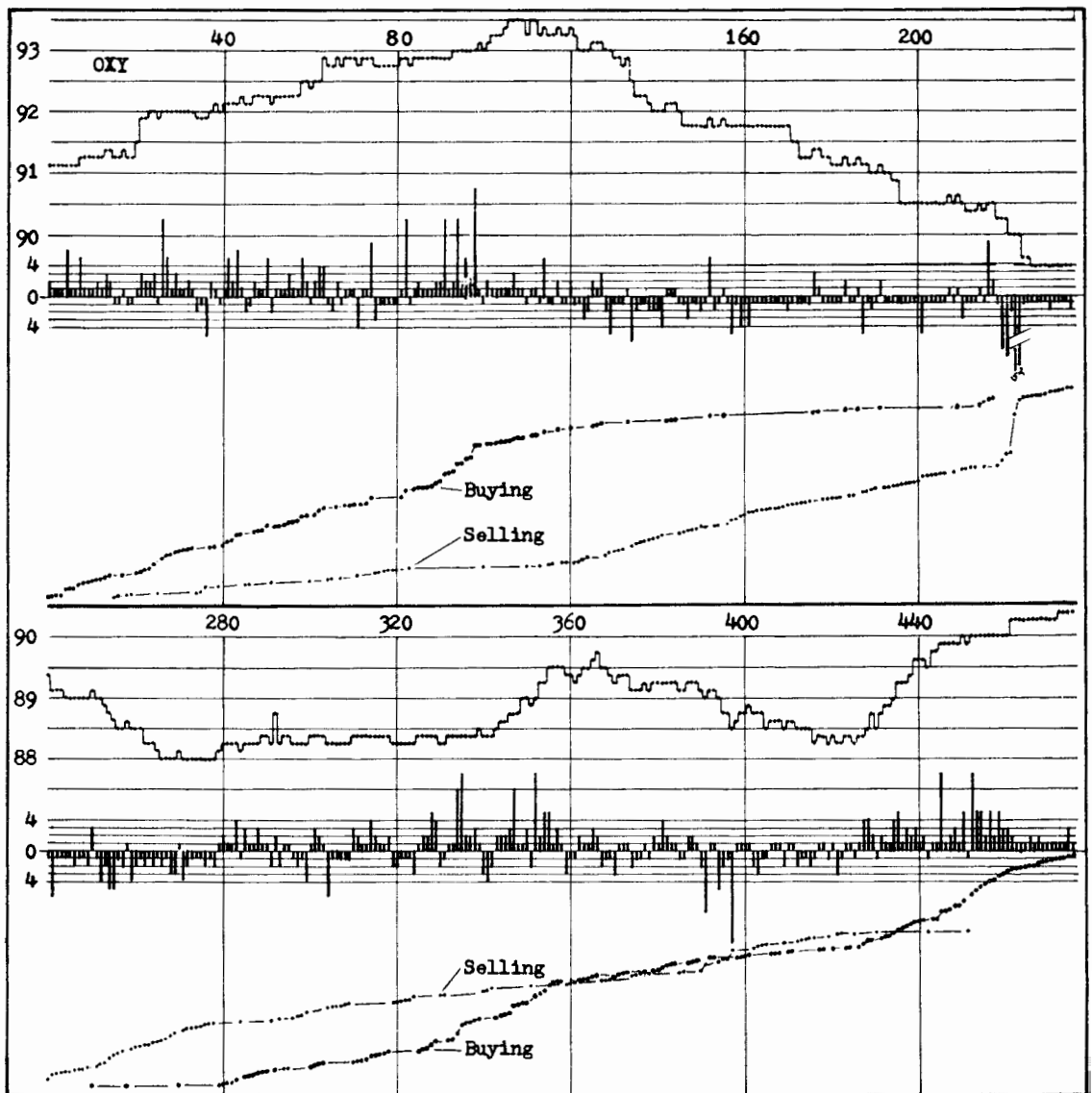

Fig. 4.4—The price-volume relationships are easily seen in the movement of a single stock—Occidental Petroleum—during a day's trading activity.



As we can see in Fig. 4.4, most of the volume from the opening of trading was buying volume until the price peaked at $93\frac{1}{2}$. From then on, most of the volume was selling volume. Something changed when the stock hit $93\frac{1}{2}$. Buyers were no longer so eager and persistent in their buying as they were earlier, and sellers, who were mostly in the background until the $93\frac{1}{2}$ price was reached, now became dominant, so the bar volume pattern, instead of being interspersed with occasional sales, was now interspersed with occasional purchases. Volume, as we can see, remained mostly steady—or at a fairly regular rate—during both the up and the down movement of price. When we accumulate the totals of the two types of volume, however, we can see more clearly what happened in the trading of the stock. That is, buyers were eager from the first transactions (the first block transaction of 75,000 shares and two succeeding 100-share trades at the opening price are eliminated) and remained eager to buy the stock until price reached 93, as shown by the slope of the accumulation line. From this point, there were not so many aggressive buyers, even though price went upward another half-point. When the peak was established at $93\frac{1}{2}$, sellers became more aggressive and the slope of the accumulated selling volume line began to move sharply upward.

When price declined from $93\frac{1}{2}$ to 90, two blocks of 5000 and 2000 shares came to market, and, at this point, the balance between accumulated buying volume and selling volume was equal, or the two opposed forces were at equilibrium. We must note that this balance on the part of the volume forces occurred a point and five-eighths lower in price than at the beginning.

In the lower portion of the illustration, we see that when price reached 90, at trade 223, the forces were equal but, as price declined further, selling continued upward until the price declined to 88. At this point, buyers were again activated and the buying line, this time not so eager and interspersed more with selling volume, again started an upward movement. The forces came to a balance point when price reached $89\frac{1}{2}$ at trade 355 and remained at or near-balance while price dropped to $88\frac{1}{4}$ and buyers again came into the picture. In the interval between trades 360 and 400, it is interesting to note there was actually a little more buying than selling while prices declined from $89\frac{1}{2}$ until they reached $88\frac{1}{2}$. From $88\frac{1}{2}$ to the next low at $88\frac{1}{4}$, between trades 400–440, selling again gained dominance.

Now, as we can see from the illustration: (1) buying continues eagerly when a stock climbs from an obviously low point to a questionable high point; (2) selling then becomes dominant on the decline from the peak; (3) somewhere along the line the two opposed volume totals will reach equilibrium at a price which may or may not be higher than the beginning price; (4) there is a tendency for buyers to come in when price first declines and for sellers to increase as price declines further.

In any event, we can see that there is a relationship between the price of a stock and the buy-sell relationship of volume.

An example of breaking individual stock volume into two totals

Most of us have neither the time nor the capacity to determine buying and selling volume relationships for single stocks by tick-counting the volume. Also, on occasion, the totals can be misleading, as we witnessed when the 5000 and 2000 share blocks



of stock suddenly closed the gap between our accumulated totals of buying and selling volume. Counting the volume of each and every stock traded, also, is unnecessary if we use the relationship of price and volume we noted earlier. That is, if we determine the upward travel of price and the downward travel of price, we establish a ratio between the two and can break volume into two parts. This has the effect of "averaging out" the random effects of big blocks of stock and still gives us a workable figure which is closely related to what happens in the market.

For instance, on the day in question, Occidental Petroleum traded 287,600 shares, according to the exchange record. The price of the stock moved down from the Friday close of $94\frac{7}{8}$ to open at 91, and then to a high of $93\frac{1}{2}$, a low of 88 and a closing price of 92. Since the high for the day was lower than the previous close, there was no upward movement from the close to the high, and the upward movement of the stock was contained in the movement from the low to the close—or a total of four points or 32 eighths. The downward movement of the stock, from the previous close to the low of 88, was $6\frac{7}{8}$ points, or 55 eighths. We have, thus, a ratio for breaking volume in the stock into upward and downward volume. If we multiply the 287,600 shares by the upward move of 32 eighths and divide the total (9,203,200) by 87 (the total movement), we have a result for buying volume of 105,800 (roughly), and, subtracting this from the total volume, we have a total of 181,800 for selling volume.

When we counted the volume which showed on the tape, we wound up with a total of 279,000 shares (a discrepancy of 8600 from the official figure)—106,700 shares of buying volume and 172,300 shares of selling volume—a difference of only a small amount, since the calculated buying volume was 36.78% of the total, on the 287,600 share basis, and the counted volume was 38.51% of the counted total. By using the price movement ratio to break volume for individual stocks, then, we can arrive at a good approximation of how much buying and how much selling was present in a day's trading. Blocks, of course, are a problem and cause most of the variation between these results and tick-counting results. Also the method works best on large-volume stocks and poorly on low volume.

How advance-decline figures improve the visibility of price moves

Now question 4 remains to be solved. How can we be sure there are any rhythms beating in the market—or is all the action really the result of accident, randoms, news events or the equalization of price to value and all the related knickknacks? The solution to the problem, once again, must start with the assumption that price is a most unreliable indicator of what is going on in the market and that, if we are to find the truth in the weedpatch, we have to remove more of the weeds.

To do this, we substitute the count of stocks which advanced and those which declined for the upward and downward movement of prices in an average such as the Dow. When we have made this substitution, it becomes a little clearer to us what is actually going on in the market as a whole—not because the Dow is composed of only 30 stocks—but because we can see stock price relationships in the A-D figures. That is, while the Dow may or may not register a change for the day, the A-D figures will



almost always show a balance of either advances or declines. It does us little good, really, to know that the Dow advanced 0.50 or 2.00 points in a day's trading, but if we know that when the Dow advanced only 50¢ there were 800 stocks which advanced and 600 which declined, we have a better picture of what is happening. Also, if the Dow advances 10.54 points, as in our earlier illustration, it is still better to know that the upward movement in the market was so powerful that it carried 1047 stocks with it, as opposed to only 365 which declined. By using the A-Ds as our indicators of price, then, we translate the movement of the average into a set of opposed figures which display the real power of a movement in the market. This brings up the only really important flaw in the A-Ds. A stock can move as much as \$5 or \$10 and still be counted as a single advance, just the same as a stock which advanced only an eighth of a point—but, like straightening out the travel of the Dow, the benefits outweigh the drawbacks.

There are a few other things we need to know about the A-Ds. First, the number of stocks advancing usually increases when the market—as measured by the averages—is up, and the number also decreases when the averages are declining. That is, it is unusual for more stocks to be advancing when the averages are going down, although it happens on occasion.

Second, the A-Ds operate in a universe, since there are only so many stocks listed on the NYSE and, therefore, a limit as to how many can advance or decline in a day's trading. As a result, when an upward movement is on, there are more stocks going up and, also, fewer stocks going down, since there is a limit to the possible total. The advances, thus, work oppositely to the declines. When one increases in number, the other obviously must decrease. From the mere quantity of advances and declines, we can, with a little practice, tell what is happening in the market from simple observance of the A-D totals.

Third, as we shall demonstrate, the relationship of price and volume remains largely undisturbed by the substitution of A-Ds for prices. That is, an advancing stock has advanced because there were more buyers than sellers in the stock on that day, regardless of the quantity of volume of trading. Even if only 100 shares were traded, if the price was up, it was up as the result of a buyer wanting that stock and being willing to pay a little higher price to get it.

We can see, then, that substitution of advances and declines for prices in the market gives us a better picture of market action than the price movement of an average such as the DJI. Since we are concerned, first, with market movement, anything we can do to improve our visibility of the market as a whole is a help.

III—How to Set Up the Statistics for TORQUE Analysis

The basic statistical method involved in TORQUE analysis is the moving total. The total moves by the addition of new input numbers and the subtraction of old outgo numbers from one total length previous. For instance, if our total consisted of 10 values of 1000 each, the moving total at that point would be 10,000. If the next new input



number was 700, the total would decline to 9700 by the subtraction of the first 1000 figure and the addition of the new 700 figure. A moving total always exactly equals the sum of the numbers within the total.

The moving total is also a mathematical filter which catches and retains the differences between large and small numbers as they meet and adds the differences to, or subtracts them from, the total. For instance, if a new input figure was 999 and the old outgo figure was 444, the total would increase by the extra 555 value of the new number. That is, 444 of the new number would be washed out of the filter with the old outgo number and the 555 difference would be retained in the filter until all, or part of it, was eliminated when the 999 input number became an outgo number and was, in turn, matched against a new input. If the newest input was 777, the value of 777 would be washed out of the old 999 number, but 222 of the values would remain in the total due to the filter action of the total, since it always matches the old against the new. A moving total is like using coffee grounds a second time. There is still some flavor remaining, but a lot of it got washed out on the first brew and still more will be washed out on each successive brew.

A moving total, then, has two functions: (1) it is always the sum of the values within its length and (2) it filters each new input figure against the old outgo figure, retaining within the total any residue (difference) between the two numbers.

Now cycles move largely by the net differences between thrust and recoil—between input and outgo, so to speak—which is the same way moving totals move. So, when we measure cycles with moving totals, we are essentially measuring a thrust against a previous recoil and a recoil against a previous thrust—if our moving totals are of the proper length (and if the thrusts are regular in time).

By the moving total method, then, we compare apples with apples, each with each or bushel by bushel, without reference to the calendar. The calendar expresses only one cycle—the earth's annual trip around the sun—but we are interested in many cycles of differing lengths, so we must compare cycle to cycle and forget the annual cycle for comparison purposes, which is the trouble with many market analyses.

Why moving totals should equal a cycle radius

When we have substituted the A-Ds for price and have separated whole volume into buy-sell totals, we have daily measurements of the four basic forces in the market. That is, on any day, we can easily determine in concrete figures what proportion of upward movement there was in market prices and how much downward movement occurred. We also can see, in numbers, the quantity of the two types of volume which powered the movements. We have, then, reduced the basic forces to concrete figures. Now it remains to set up the relationships which exist between the four forces. This we do by building moving totals, one for each of the forces, and, as we shall see later, one set for each of the cycles which we wish to study.

We learned earlier that the radius of a cycle, or the amplitude of swing, was about the only measurement which remains a near-constant in the cyclical equation. If each cycle version was built by equal thrust, the radius of the cycles within the series would remain constant, since the amplitude of each cycle would be the same. Also, since the



amplitude was equal, the length (diameter) would be the same, except as it was affected by adjacent cycles. In practice, both amplitude and length do vary, but, for our purposes and with little loss of accuracy, we can assume that the radius of each cycle is a constant.

From this basis, we can see that, if we are to get an accurate measurement of a cycle, our moving totals of the four basic forces should equal the length of the radius of the cycle involved.

In addition to this basic consideration, there are other reasons for using the radial length for our totals. With this length, we are measuring the full vertical (price) value of a cycle. That is, by starting at a trough of a cycle and measuring vertically to the peak, which is expected to be at about the halfway point of the cycle length, we will obtain the maximum swing of prices.

If we use lengths shorter than the radius, our measuring rod will not be big enough to measure the whole swing, and, if we use lengths longer than the radius, our measuring rod will bend over the top of the cycle, so that, again, we will not have a true measurement. On the other hand, if we measure a cycle with a moving total which is the length or diameter of the cycle, the result we obtain is not a measure of amplitude but a measure of trend. That is, a total of the length of a cycle would record a trough vs. a trough and a peak vs. a peak, and the difference would be only the trendular value which might underlie the cycle.

We keep talking about cycle radius as if it were a time measurement instead of a vertical measurement, since we have defined radius as the amount of thrust a cycle produces. The problem is resolved if we average the duration, or time-length, of a series of thrusts. That is, a thrust takes time to develop to its full potential. In a short cycle, a thrust may reach great proportionate amplitude compared with other versions, but the time involved in reaching a great or a small amplitude will be about the same in each case. This is because cycles (and cycle radii) come in pretty finite lengths or, as we have seen, generally in multiples of the basic cycle. When we speak of radius as the length for our moving totals, then, we indicate an average of the length of time the thrust consumes in reaching its apex. A 10-week cycle usually has a radius thrust of about five weeks' duration, but the recoil (and the diameter) is dependent on conditions which exist outside the cycle's circumference. A recoil is not a force in the sense of a thrust. It has force, but it drifts as the force diminishes.

The link relationship between numbers in a time series

In a time series—or a series of numbers moving through time—every element of the series, except the first and the last, is related to both the predecessor and successor numbers. That is, a figure such as 1244 advances (which shows on the 48th Monday in Table 4.1) and is most likely to occur not because it is a result of an accident or a *specific event but because it is a part of a cyclical chain of numbers. While it may be affected by a random, only part of its value can be attributed to the random, since the other part of its value is due to trend, to cyclical or seasonal forces or to all three.*

In other words, the figure 1244, being the link between 907 and 938 in the series, is indicating that part of its size is accounted for by an extraordinary amount of buying in the market on that day but that the bulk of its quantity (approximately 900 of the



Week	ADVANCES				DECLINES				BUY VOL.				SELL VOL.							
	New	Old	5-da Total	25-da Total	New	Old	5-da Total	25-da Total	New	Old	5-da Total	25-da Total	New	Old	5-da Total	25-da Total				
(44)	659	(485)	2793	(658)	14851	611	(765)	3666	(665)	17849	518	(387)	2534	(639)	14937	429	(533)	2543	(800)	15418
	924	(493)	3224	(838)	14937	385	(804)	3247	(508)	17726	732	(425)	2841	(943)	14726	444	(543)	2444	(845)	15017
	707	(572)	3359	(681)	14963	597	(717)	3127	(647)	17676	670	(563)	2948	(743)	14661	548	(503)	2489	(748)	14817
	507	(537)	3329	(628)	14842	693	(786)	3034	(666)	17703	559	(457)	3050	(485)	14735	521	(587)	2423	(485)	14853
	637	(532)	3434	(954)	14525	627	(748)	2913	(388)	17942	497	(571)	2976	(903)	14329	480	(481)	2422	(639)	14694
(45)	817	(659)	3592	(1047)	14295	524	(611)	2826	(365)	18101	645	(518)	3103	(1224)	13750	444	(429)	2437	(752)	14386
	723	(924)	3391	(719)	14299	578	(385)	3019	(673)	18006	593	(732)	2964	(1155)	13188	610	(444)	2603	(869)	14127
	850	(707)	3534	(630)	14519	479	(597)	2901	(674)	17811	729	(670)	3023	(807)	13110	823	(548)	2678	(754)	13996
	351	(507)	3378	(401)	14469	1019	(693)	3227	(966)	17864	271	(559)	2735	(531)	12850	981	(521)	3138	(919)	14058
	358	(637)	3099	(400)	14427	977	(627)	3577	(934)	17907	300	(497)	2538	(447)	12703	889	(480)	3547	(951)	13996
(46)	496	(817)	2778	(333)	14590	801	(524)	3854	(929)	17779	464	(645)	2357	(331)	12836	452	(444)	3555	(526)	13922
	638	(723)	2693	(488)	14740	617	(578)	3893	(784)	17612	479	(593)	2243	(382)	12933	465	(610)	3410	(568)	13819
	342	(850)	2185	(608)	14474	939	(479)	4353	(642)	17909	269	(729)	1783	(594)	12658	716	(623)	3503	(448)	14087
	578	(351)	2412	(702)	14350	703	(1019)	4037	(613)	17000	495	(271)	2007	(659)	12494	433	(981)	2955	(466)	14054
	831	(358)	2885	(409)	14772	444	(977)	3504	(882)	17579	652	(300)	2359	(442)	12704	440	(889)	2506	(688)	13806
(47)	899	(496)	3288	(295)	15376	488	(801)	3191	(1059)	17008	750	(464)	2645	(314)	13140	522	(452)	2576	(675)	13653
	849	(638)	3499	(660)	15565	490	(617)	3064	(635)	16863	733	(479)	2899	(575)	13298	523	(465)	2634	(488)	13688
	835	(342)	3992	(627)	15773	516	(939)	2641	(653)	16726	723	(269)	3353	(584)	13437	623	(716)	2541	(549)	13762
	871	(578)	4285	(446)	16198	458	(703)	2396	(855)	16329	540	(493)	3448	(406)	13621	590	(433)	2698	(494)	13858
	907	(831)	4361	(707)	16398	399	(444)	2351	(563)	16165	613	(652)	3409	(549)	13685	400	(440)	2658	(478)	13780
(48)	1244	(899)	4706	(683)	17157	230	(488)	2093	(765)	15630	1124	(750)	3783	(387)	14422	646	(522)	2782	(533)	13893
	938	(849)	4795	(493)	17602	507	(490)	2110	(804)	15630	1014	(733)	4064	(425)	15011	1003	(523)	3262	(543)	14354
	1032	(835)	4992	(572)	18062	401	(516)	1995	(717)	15017	1068	(723)	4409	(563)	15516	728	(623)	3367	(503)	14578
	966	(871)	5087	(537)	18491	487	(458)	2024	(786)	14718	1188	(590)	5007	(457)	16247	860	(590)	3637	(587)	14851
	910	(907)	5090	(532)	18869	484	(399)	2109	(748)	14454	939	(613)	5333	(571)	16615	659	(400)	3896	(481)	15029
(49)	919	(1244)	4765	(659)	19129	845	(230)	2354	(611)	14318	845	(1124)	5054	(518)	16942	708	(646)	3958	(429)	15308
	545	(938)	4372	(924)	18750	835	(507)	2682	(385)	14768	602	(1014)	4642	(732)	16812	835	(1003)	3790	(444)	15699
	669	(1032)	4009	(707)	18712	668	(401)	2949	(597)	14839	681	(1068)	4255	(670)	16823	674	(728)	3736	(548)	15825
	799	(966)	3642	(507)	19004	552	(487)	3014	(693)	14698	864	(1188)	3931	(559)	17128	597	(860)	3473	(521)	15901
	838	(910)	3770	(637)	19205	550	(484)	3080	(627)	14621	910	(939)	3902	(497)	17541	669	(659)	3483	(480)	16090
(50)	493	(919)	3344	(817)	18881	886	(475)	3491	(524)	14983	613	(845)	3670	(645)	17509	768	(708)	3543	(444)	16414
	582	(545)	3381	(723)	18740	778	(835)	3434	(578)	15183	563	(602)	3631	(593)	17479	779	(835)	3487	(610)	16583
	680	(669)	3407	(850)	18570	670	(668)	3436	(479)	15374	697	(681)	3647	(729)	17447	727	(674)	3540	(623)	16687
	814	(799)	3407	(351)	19033	515	(552)	3399	(1019)	14870	766	(864)	3549	(271)	17942	600	(597)	3543	(981)	16306
	777	(838)	3346	(358)	19452	549	(550)	3398	(977)	14442	734	(910)	3373	(300)	18376	702	(669)	3576	(889)	16119

Table 4.1—Construction of 5- and 25-day moving totals of advances and declines, buying and selling volume.



TORQUE Analysis of Stock Market Cycles

Week	DOW JONES INDUSTRIALS				TRENDS			VOLUME			CYCLICAL STRENGTHS								
	High	Low	Closes	Chg	10-Day (2 week)		50-Day (10 week)		New	Old	Total	5-Day (2 week)	Price Volu	TORQUE	25-Day (10 week)	Price/Volume	Ratio		
					Old	Total	Aver.	Old	Total	Aver.									
(44)	762.25	750.68	758.01	+240	756.50	756,975	756.98	759.58	3,809,850	761.97	947	(920)	5077	7619	9965	0.7646	8320	9688	0.8588
	771.50	756.02	768.07	+1006	75883	757,899	757.90	75897	3,810,760	762.15	1176	(968)	5285	9929	11624	0.8542	8427	9806	0.8534
	777.25	764.92	770.81	+274	75965	759,015	759.02	76047	3,811,794	762.36	1218	(1066)	5437	10742	11844	0.9070	8465	9895	0.8555
	775.94	765.68	771.56	+75	75787	760,384	760.38	75979	3,812,971	762.59	1080	(1066)	5473	10972	12588	0.8716	8384	9921	0.8451
	777.38	765.81	771.97	+41	75938	761,643	761.64	76581	3,813,587	762.72	977	(1052)	5398	11789	12287	0.9595	8096	9752	0.8302
(45)	782.38	769.85	777.66	+569	75643	763,766	763.77	76458	3,814,895	762.98	1089	(947)	5540	10157	12710	0.7986	7897	9558	0.8262
	783.00	773.34	777.38	-.28	75445	766,059	766.06	75915	3,816,818	763.36	1203	(1176)	5531	11232	11387	0.9864	7941	9335	0.8507
	788.75	776.29	779.50	+212	75596	768,413	768.41	75664	3,819,104	763.82	1382	(1218)	5665	12182	11288	1.0792	8152	9367	0.8703
	781.76	765.88	768.00	-1150	75356	769,857	769.86	76527	3,819,377	763.88	1252	(1080)	5837	10468	8716	1.2010	7932	9141	0.8677
	767.94	755.61	759.79	-821	75561	770,275	770.28	77115	3,818,241	763.65	1189	(977)	6049	8664	7155	1.2109	8057	9076	0.8877
(46)	764.99	752.46	760.13	+34	75801	770,487	770.49	77214	3,817,040	763.41	916	(1089)	5876	7208	6630	1.0872	8206	9220	0.8900
	768.48	756.78	760.47	+34	76807	769,729	769.73	77314	3,815,773	763.15	944	(1203)	5617	8369	9359	1.0517	8369	9359	0.8942
	761.77	751.78	754.24	-623	77081	768,072	768.07	76643	3,814,554	762.91	985	(1352)	5250	5020	5090	0.9862	8082	8986	0.8994
	760.47	749.52	755.82	+158	77156	766,498	766.50	76075	3,814,061	762.81	928	(1252)	4926	5975	6792	0.8797	7973	8890	0.8969
	764.10	752.19	761.57	+575	77197	765,456	765.46	76184	3,813,039	762.61	1092	(1189)	4829	5403	9202	0.9132	8903	9202	0.9132
(47)	773.41	759.79	767.52	+295	77266	764,442	764.44	75712	3,814,079	762.82	1272	(916)	5185	10304	10268	1.0035	9040	9624	0.9393
	775.60	762.60	772.73	+521	77766	763,977	763.98	75055	3,816,297	763.26	1256	(944)	5497	11420	11006	1.0376	9230	9715	0.9501
	780.94	768.48	774.71	+198	77950	763,498	763.50	75431	3,818,337	763.67	1346	(985)	5858	15115	13196	1.1454	9430	9764	0.9658
	Holiday		(778.03)		76800	764,501	764.50	75767	3,820,373	764.07	(1180)	(928)	6110	17884	12780	1.3994	9920	9829	1.0093
	783.61	771.15	781.35	+664	75979	766,557	766.66	75849	3,822,659	764.53	1013	(1022)	6067	18550	12825	1.4464	10144	9931	1.0214
(48)	797.51	780.26	794.09	+1274	76013	770,053	770.05	75192	3,826,876	765.38	1770	(1272)	6565	22484	13598	1.6535	10977	10381	1.0574
	805.65	787.45	794.29	+20	76047	773,435	773.44	74747	3,831,558	766.31	2017	(1256)	7326	22725	12459	1.8240	11480	10458	1.0977
	805.72	887.86	802.64	+835	75424	778,275	778.28	75438	3,836,384	767.28	1796	(1346)	7776	25023	13095	1.9109	12028	10655	1.1289
	916.88	801.48	808.53	+599	75582	783,546	783.55	75931	3,841,306	768.26	2048	(1180)	8644	25133	13767	1.8256	12564	10675	1.1770
	819.07	801.34	816.06	+753	76157	788,995	789.00	76177	3,846,735	769.35	1598	(1013)	9229	24135	13688	1.7632	13055	11055	1.1809
(49)	823.59	810.24	818.66	+260	76752	794,109	794.11	75897	3,852,704	770.54	1553	(1770)	9012	20242	12769	1.5852	13760	11067	1.2072
	822.49	809.69	815.10	-356	77273	798,346	798.35	76088	3,858,126	771.63	1437	(2017)	8432	16301	12248	1.3309	12696	10709	1.1855
	819.96	806.27	815.24	+14	77471	802,399	802.40	76068	3,863,582	772.72	1355	(1796)	7991	13594	11389	1.1936	12610	10631	1.1862
	824.75	811.68	821.06	+482	77803	806,702	806.70	76068	3,869,620	773.92	1461	(2048)	7404	12747	11318	1.1263	12930	10772	1.2003
	831.67	818.18	825.92	+486	78135	811,159	811.16	76616	3,875,596	775.12	1579	(1598)	7385	12240	11203	1.0926	13135	10902	1.2048
(50)	832.28	818.66	823.18	-274	79409	814,068	814.07	77670	3,880,244	776.04	1381	(1553)	7213	9579	10358	0.9248	12602	10667	1.1814
	826.12	813.25	819.62	-356	79429	816,601	816.60	78245	3,883,961	776.79	1342	(1437)	7118	9846	10413	0.9455	12343	10540	1.1711
	823.52	810.17	819.07	-55	80264	818,244	818.24	78368	3,887,500	777.50	1424	(1355)	7187	9872	10302	0.9583	12079	10455	1.1553
	826.94	815.85	822.15	+308	80853	819,606	819.61	77704	3,892,011	778.40	1366	(1461)	7092	10024	10017	1.0007	12800	11003	1.1633
	828.97	815.51	822.77	+62	81606	820,277	820.28	78669	3,897,419	779.48	1436	(1579)	6949	9847	9432	1.0440	13469	11400	1.1815

Table 4.2—Construction of trends, whole volume total and cyclical strength vectors.

values) probably would have occurred regardless of the random exuberance in the market on that Monday. For instance, in Table 4.2, we see that the Dow industrial average recorded a 12.74 point advance on Monday of the 48th week. We can also see that the following day the advance amounted to only 0.20 points but that on Wednesday, the gain was again a sizeable amount—8.35. Monday of the 48th week borrowed strength from Tuesday of that week because of a surge of optimism.

We also can see in Table 4.1 that, while the advances total moved upward sharply on Monday of the 48th week, the declines total dropped swiftly, since the total of declines on that day was only 230. This, too, was a part of a series, since it represented a link in the fairly orderly decline of the total to be followed shortly by an upturn of the total.

In the volume columns of Table 4.1, we see that different things were happening. The high figure of 1244 advances was recorded on 11.24 million shares of buying volume and on 6.46 million shares of selling volume. Both of these figures represented an increase over previous figures, and both the five-day and the 25-day values of buying volume moved sharply upward—but the same thing also occurred to a lesser extent in the two totals of selling volume. That is, while there was a large excess of buyers over sellers on Monday of the 48th week, there was also a buildup of the quantity of selling.

The results of these buildups of strength in the four moving totals is summarized in the cyclical strengths columns of Table 4.2. On Monday of the 48th week, we notice that the five-day totals of advances vs. declines resulted in a factor of 2.2484 (4706: 2093) and the 25-day totals in a factor of 1.0977 (17.157: 15.630).

Cyclical strength of the 10-day cycle has a practical limit of about 2-to-1, so we know that if the price side of the equation is above 2.0000, it will require an increase in the divisor if the equation is to hold. The buildup of buying volume took care of the problem. That is, the 1124 addition to the total brought the relation between buying and selling volume in the five-day totals to a factor of 1.3598 (3783: 2782), so that when the price factor (2.2484) was divided by the volume factor (1.3598), the cyclical factor became 1.6535 for that day.

In the 25-day totals, the increased advances and increased buying volume had less effect, so that the total of advances exceeded the declines total by only 1.0977 and the buying volume total exceeded selling by only 1.0381, so the 10-week cycle strength moved up only to 1.0574. As we can see, then, the longer the cycle with which we are dealing, the greater amount of force it requires to make the cycle move and the less effect a random can have on the total.

The “random” in this case was the discovery by the Federal Reserve of a \$7 billion “mistake” in the money supply figures. The following day, Tuesday, another random was counted in the figures, particularly the volume figures, since after the Monday



closing, the Fed reduced the discount rate by a quarter-point. This contributed to the 20.17 million-share day on Tuesday of the 48th week we see in the volume column of Table 4.2. Also shown in Table 4.2, is the daily calculation of two trends—a short two-week or 10-day trend which is the length of the diameter of the two-week cycle and, also, a 50-day trend which fits the 50-day or 10-week cycle. Please note that these lengths are double the lengths which we use for measuring cycles. For cycles, we use half the length of the cycle. For trends, we use the full length of the cycle.

How to compute the TORQUE factors of cycle forces

The mathematics involved in making moving totals is quite simple. After the initial totalling of the figures, the total moves by the simple addition of the new input figure and the subtraction of the old takeaway number from the total, whether the moving total represents a cyclical radius or a cyclical trend. That is, a cyclical radius of a 50-day cycle is simply a 25-day total of daily figures; a cyclical trend of a 50-day cycle is simply a 50-day total of daily figures averaged (divided by 50)—and both progress by addition and subtraction. This holds for all of the moving totals: advances, declines, buying volume, selling volume, trends and the raw volume figures.

The cyclical strength factors, however, require a little more explanation. First, as we know, the formula for arriving at a TORQUE (or cyclical strength) factor is: $\frac{\text{Price Movement}}{\text{Volume Balance}} = \text{Cyclical Strength}$.

Since we are dealing with real numbers in each of the moving totals, we can arrive at a factor between the opposed forces of price by dividing the advances moving total by the declines moving total $\left[\frac{\text{Advances}}{\text{Declines}} = \text{Price Movement} \right]$, and the difference between them will be described in a factor which is more or less than 1.0000. For instance, on Monday of the 44th week, the five-day advances total was 2793 and the declines total was 3666. When we divide them, the price movement factor becomes 0.7619, or, simply, the advances total is only 76% of the declines total. Similarly, buying volume total on that day was 2534 and the selling volume total was 2543. When we divide buying by selling volume $\left[\frac{\text{Buying Volume}}{\text{Selling Volume}} = \text{Volume Balance} \right]$, we arrive at a factor of 0.9965, or buying was 99.65% as strong as selling. These figures we find in Table 4.2, in the cyclical strengths column. The relationship of these numbers is described by the right-angle relationship between opposite poles of the diameter of a circle.

The second right-angle relationship in the cyclical system, we remember, was the relationship of force and radius, or the TORQUE factor of a cycle. This factor is found in the last column of Table 4.2 and is obtained by dividing the price factor by the volume factor. For instance, on Monday of the 44th week, the price factor of 0.7619



when divided by the volume factor of 0.9965 equals 0.7646, which was the TORQUE factor of the 10-day cycle at that time.

Why price divided by volume equals radius times force

We perhaps need to explain why price divided by volume is the equal of radius times force. The key to the situation is that all four of the basic forces in the market are in moving totals of equal length for each cycle. That is, the five-day totals express the radius of the 10-day cycle and the volume factor is also adjusted to the radius length and represents the relationship between buying and selling volume—or the net force. Since we always divide advances by declines and buying by selling volume, we know that a factor of more than 1.0000 means there is more upward price movement and more buying volume, and a factor of less than 1.0000 means that the upward price and buying volume totals are smaller than their opposite numbers. Within the price totals, then, we have built in the radius of the cycle we are measuring and we have also arrived at a figure which represents the net force of volume. From the mechanical torque equation of $\text{Torque} = \text{Force} \times \text{Radius}$, we can see that when we substitute price for torque, volume for force and cycle for radius, the equation still holds.

There are also two small matters which are asking to be included here. First, when working with figures, accuracy is a must, since errors creep in. To prove our figures at the end of each week, we simply add up the five-day total to find if it is correct. Once this is accomplished, the larger totals are also easy to prove. For the 25-day total, if we go back each Friday to the previous Friday, we can add the new week's total and subtract the one from five weeks previous, and thus prove out each total.

Every so often there is a holiday in the market. This creates a problem in a moving total since there are no figures available for the holiday. The solution is interpolation or the establishment of a figure which centers between the values of the day preceding the holiday and the day succeeding the holiday. In other words, we supply the missing link in the time series. In Table 4.2, we see that Thanksgiving (Thursday of the 47th week) was allotted a volume figure of 11.80 million shares. The difference between the Wednesday and Friday figures was 3.33 million shares. Half of this (1.67 million) was added to the lesser of the two figures, the Friday figure in this case, to arrive at the Thursday figure, so that the moving totals would be complete. That is, a moving total must always contain the same number of units or it will be altered by the deficiency. Sometimes, two days in a row will be holidays. If two days are missing, the gap can be filled by dividing the difference between the last old and the new figure by three and adding the one-third portion twice to the smaller total. It is to be noted that, by interpolating the numbers, we are not really adding anything to the total—because of the link relationship between numbers—since we have mostly supplied the missing link total.

Adjusting our cycles to practical lengths

Before leaving the moving totals, we need to make a couple of adjustments in the average lengths of the two longest cycles in our chord. In Chapter 1, we estimated that the longer cycles should be 75 weeks and 225 weeks long, since these lengths were exact multiples of the 25-week cycle. In Chapter 3, however, we found that volume in the market has a seasonal pattern and, since it has been generally present in the volume pattern for many years, it is a genuine influence. That is, we learned that



volume has a distinct tendency to hit lows in February and again in July–August. Also there is a strong tendency for the market to decline during these weak volume periods and also in September–October.

Now if we used moving totals of 75 weeks and 225 weeks, the totals would be (1) three weeks short of six 13-week quarters and (2) four weeks longer than 17 13-week quarters. If we add three weeks to the 75-week cycle, we arrive at a 78-week length which coincides exactly with the quarterly pattern, and if we subtract 17 weeks from the longest cycle, we have a length which also more closely coincides with the quarterly volume pattern. We have, therefore, substituted half of these lengths for the moving totals, with the result that we now use totals of 39 weeks (three quarters) for the 78-week cycle and 104 weeks (two years) for the 221-week cycle, since, as we have found, it is more important to allow for the seasonal pattern than to stay rigidly to an exact cyclical length. That is, a very long cycle usually makes only minuscule changes in value in a few weeks, while a strong seasonal pattern, such as the volume fluctuations, will have a large effect on even a large cycle. By making adjustments in length, we match our cycles in the chord to more practical lengths than those established on a mathematical basis.

The problem of lag in moving totals

In Chapter 2, we saw that there is a lag problem in moving totals and that the problem concentrates most heavily in volume totals because of volume's constant increase and decrease and also because of its changing characteristic between buying and selling volume. Lag, however, is a problem in any sort of moving total.

A moving total will lag actual data by one-half the length of the total. If the total figure is centered, or placed opposite the central number of the series within the total, the total will be in phase mathematically with the data, as we can see in Fig. 4.5, which shows the results of three different placements of the total figure. The total pictured was formed by simply adding 1, 2, 3, 4 and 5 to arrive at 15 for the first total. In the second half of the cycle, the numbers decline by the same amounts, being 4, 3, 2 and 1, so that the cycle is nine units long and the moving total is half the length, or five units long.

With the centered moving total illustrated, the sum of the first five values is placed opposite point 3 in the cycle and the series moves to a total of 18 at point 4 by the addition of the value of 4 (from point 6) and the subtraction of the value of 1 at point 1. We can see from the illustration that the centered total matches the peaks and troughs of the raw data even though the trough of the total comes at the seventh interval of the total. The moving total, which was plotted ahead of the center of the span, peaks and troughs sooner than the data, and the end-formed (or end-plotted) total lags the peaks and troughs by half the length of the total.

From the drawing, we can see that all three of the moving totals are identical in all respects except one—the amount of lag ahead or behind the raw data in the cycle—so that, by our placement of the beginning of the total, we can control the amount of lag.

The reason we use end-formed moving totals

The principal reason for using any type of moving total is the “fit” of the total to the data involved. That is, to give us an accurate picture, a moving total should peak with the data (the Dow average in our case) and trough with the data. Since other than centered totals either lag or precede troughs and peaks in most data, centered totals are mostly used for time series data.

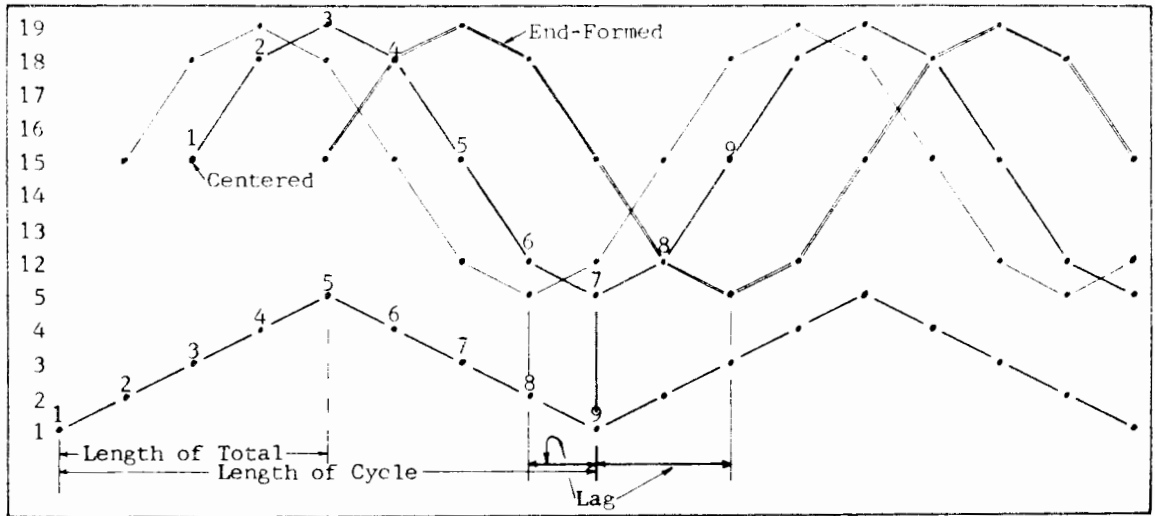

Fig. 4.5—How placement of a moving total figure affects lag of the total ahead or behind the raw data.

We find, however, that our end-plotted totals of stocks which advanced do not appreciably lag or precede the Dow average movements but are consistently in step with the Dow's movements, and it is for this reason that we use end-formed totals instead of centered ones. Now why do our end-formed totals give results as good as centered ones?

One answer, we think, lies in the nature of the raw data we use. The primary factor in TORQUE analysis cycle measurements is the daily total of advances, and this data has strong cyclical components. That is, the daily quantity of stocks advancing will swing from an average of about 400 per day at a trough to about 900 per day at a peak, and this is reflected in the short input cycle we use—the five-day moving total. This total will swing from, these days, a low of about 2000 to a high of about 4500 in the span of a few days and reverse. The advances, then, unlike prices and other data which tend to build to higher figures over longer time periods, oscillate in short thrusts and recoils from a low to a high, and to a second low which is about on a par with the first low. And this occurs over very short timespans.

Since we plot our moving totals against the Dow industrial average as a background, and since the Dow moves in response to the pull of both long and short cycles, the oscillations of the Dow and the moving totals are closely correlated, or tend to "fit" together nicely almost regardless of the length of the total. We can see that this is likely if we consider that the longer cycles are harmonic multiples of the shorter cycles and reflect the short-cycle effects with a "dampened" response. Thus, while the built-in lag of a long total is always present, its effect is minimized and it is normally a match between today's short cycle swing and a previous one. That is, if the long total is five times the length of the input cycle, it is not really material (at the moment) whether the long total is reflecting upswing 1, 3 or 5 of the short total, unless there is a major difference between the short cycle swings, which would be abnormal. We must, of course, be aware of the lag and adjust our thinking when we note the response. Since this happens only infre-



quently—when the Dow makes very large swings over a very short timespan—it is enough to be aware that lag is present.

Volume, on the other hand, works differently than the advances data. That is, volume, like actual prices, tends to build to larger and larger numbers as a move progresses. It is true, therefore, that our volume totals do lag behind market movements by about half the span of the total. Since we use volume totals only as a divisor for the advances totals, however, and since the buying and selling volume totals remain generally close in value, the lag of the volume totals does not materially affect the resultant cyclical values.

There is another factor to be considered in any decision to use end-formed totals. End-formed totals have a lag built into the total at the beginning, and there is no avoiding this factor. End-formed totals, thus, are not good when further calculation is involved. Since we use long totals principally for setting a trend and do this without further calculation, and since, also, we are aware of the lag and subsequent lack of response at troughs and peaks—we find end-formed totals are the best for our purposes because prediction is easier when you can see today's results directly.

What a chart shows us about lag in moving advances totals

The easiest way to resolve a problem such as the decision to use end-formed totals is to study a chart. In Figs. 4.6 and 4.7, we demonstrate the results obtained by the two forms of moving totals against the background of the Dow average. Now please remember that the Dow figures do not enter into the moving totals in any way, since the totals pictured are composed of 39-week totals of the advances in the market for the two years under study. The input cycle, the little five-day total, was used as both the input and the outgo cycles and the large totals built up from the differences between the input and the outgo. That is, as we can see in the first quarter of 1970, the end-formed total moved up because there were larger figures in the input cycle (the heavy line) than in the outgo (light line) cycle. This addition was immediately visible in the end-formed total.

Both the end-formed and the centered totals hit their lows in 1970. The centered total low came in the 12th week of the year and the end-formed low came in the 32nd week, since the totals were built with a 20-week lag. That is, when the end-formed total was preparing to start up in the 32nd week, the centered total was at the same level, but the total was placed 20 weeks behind the last input—or at week 12. The coming rise of the market was not yet visible in either total on the chart, since the last input, in this example, was at the end of the 32nd week. The only difference is that the end-formed total is placed opposite the last input; the centered total lags the input by half the length of the total—or 20 weeks.

Now, as we said before, it is really the “fit” of the total in which we are interested, even though the Dow does not figure in the total. To our eyes, at least, the best fit is from the end-formed total. That is, it hit a small trough at the market low in the 21st week, and, while it was late rebounding from the low (hitting its actual low in the 32nd week instead of the 21st), the path it describes appears to follow the path of the Dow better. The centered total, on the other hand, lagging the new data by 20



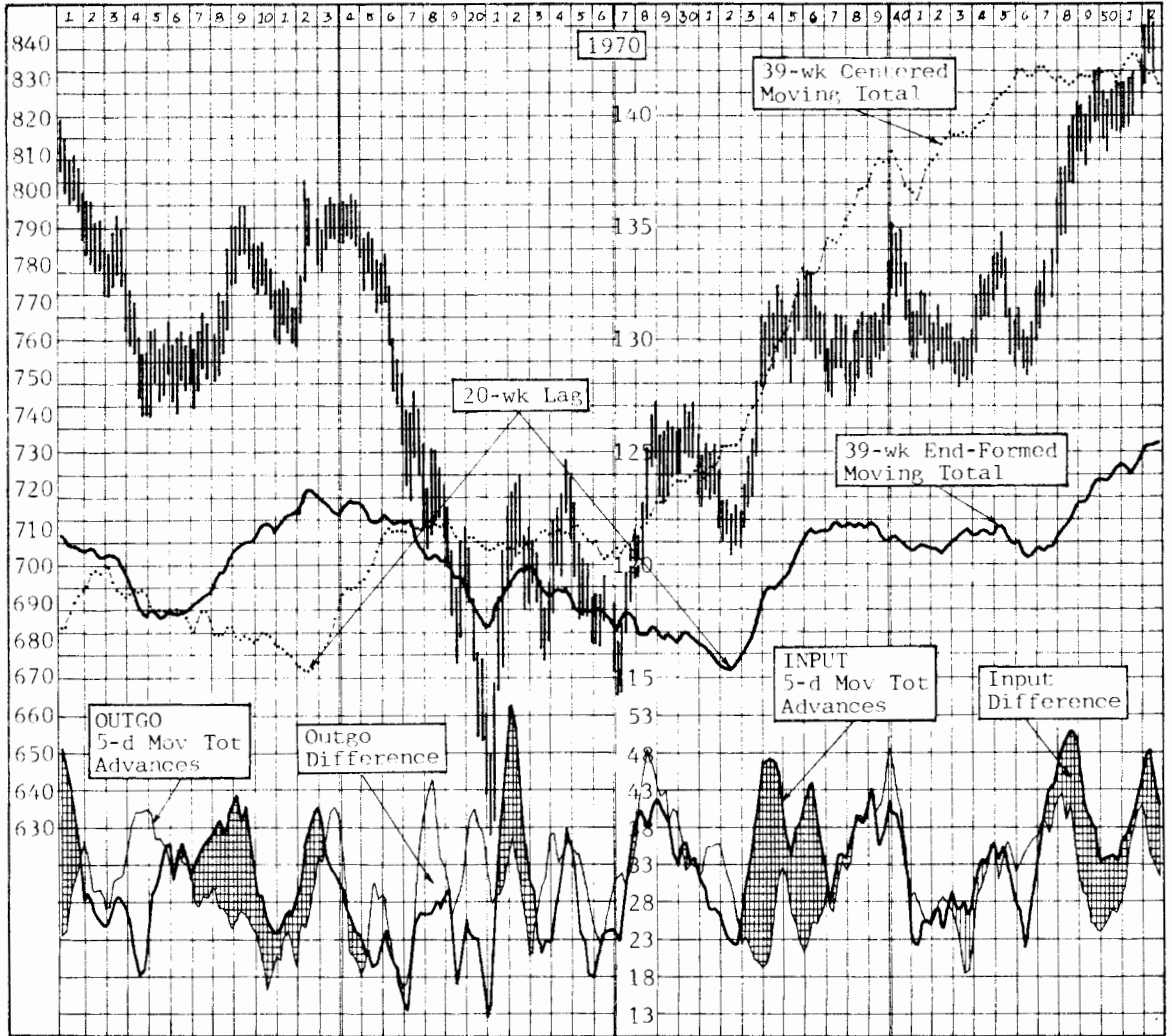

Fig. 4.6—The lag of moving totals against the 1970 background of the Dow average. The filtering action in moving totals.

weeks, hit its low at the peak of the Dow in the first quarter of 1970 when the Dow was at about 800 and peaked out when the Dow was at 840 in the final quarter.

The centered total hit its second trough in the middle of 1971 while the Dow was at about 900 and was going up while the Dow was declining to the 790 low. The end-formed total, however, peaked with the Dow at 960 early in the second quarter and troughed with the Dow in the 47th week.

The filtering action inherent in moving totals

Figs. 4.6 and 4.7 also demonstrate how moving totals progress and how they filter values statistically. First, as we can see from the charts, the totals move by the

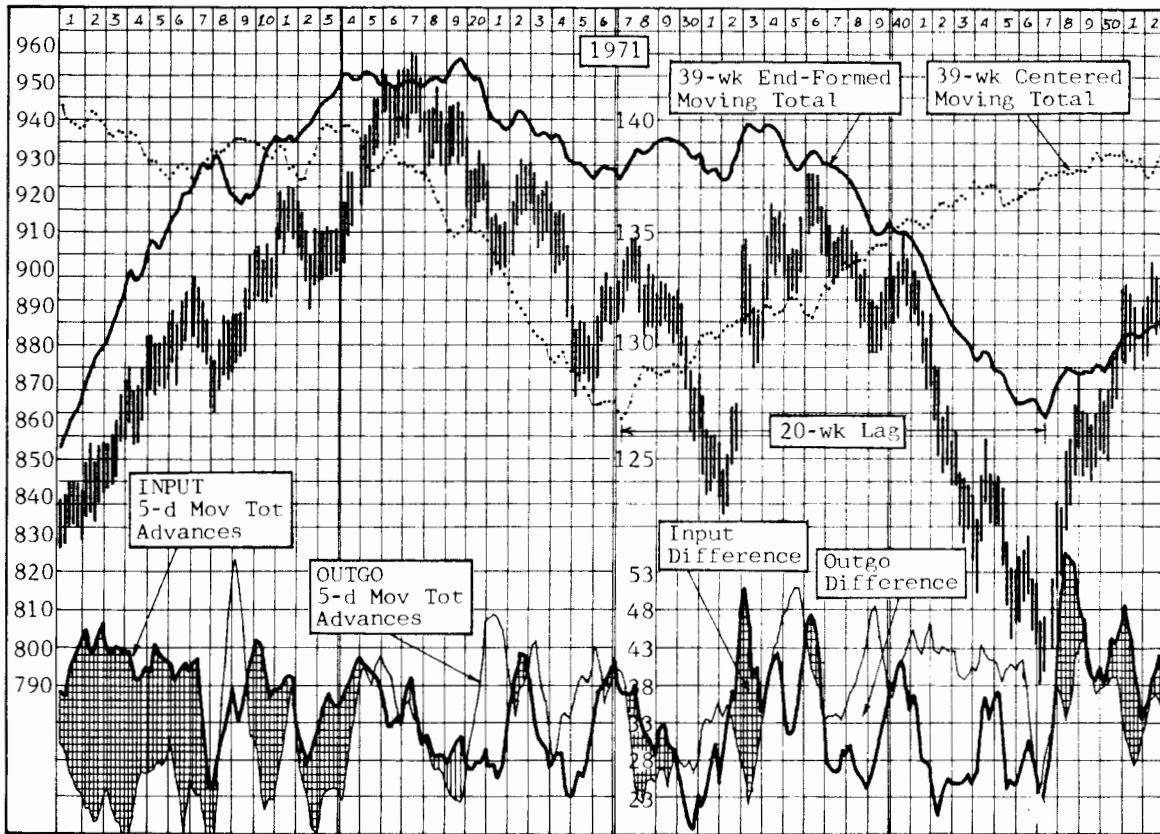

Fig. 4.7—The 39-week centered and end-formed moving totals in the 1971 down-slide of the Dow.

difference between input and outgo. At the bottom of the drawings, we have used five-day moving totals of advances for input and outgo. As we can see, the lines are identical for both types of moving totals.

The residue, or the difference between input and outgo which the moving total filter catches, is shown in the drawing as cross-hatched areas, when input is larger, and as blank areas when outgo is larger. For instance, near the end of the first quarter of 1970, we can see that input was outdistancing outgo by a considerable amount each day, and, since the residue of difference between the figures was positive, the end-formed total rose immediately by the amount of difference filtered out. In the first part of the second quarter, the relationship changed and outgo considerably exceeded input, so that, since the residue was negative, the moving total came down. The positive surplus of the first quarter was washed out of the total by the negative surplus of the second quarter. We can see, then, that end-formed moving totals have a direct visible

relationship with each day's input figures. If the input is larger than the outgo, the total increases.

Centered totals, on the other hand, respond less visibly to current events. A centered total responds not to adjacent input-outgo events but to those which are half-a-total length ahead of the total. That there is no difference between the two totals can be seen by comparing the tracks of the two, with a 20-week lag in results for the end-formed total behind the centered total, even though the end-formed total *appears* to be making a direct response while the centered total *appears* to be independent of the new input-outgo relationship.

With either method, however, we must remember that lag is always present.

IV—What the Charted TORQUE Statistics Reveal

If we only get one idea across in this whole section, let it be this: *Stocks move together.*

When a cycle starts up, or, better, when a chord of cycles starts up, a very large majority of all stocks on the New York exchange, the American exchange and, even, over-the-counter stocks, will make moves almost simultaneously. Some of them will make large moves upward with the cycles, some will make small moves and some will make medium moves, but they all will make at least an effort to increase in price. Similarly, when the cycles top out and start down, it will be a rare stock which fails to follow the cyclical downturn.

There are exceptions, to be sure, but the very great bulk of all stocks will follow a cyclical swing in price, and the exceptions, we will find on investigation, have a great "story" or fundamental reason why they are able to move at odds with the cycles. Mobile home stocks, for instance, went against the market in the 1969–70 drop, but they were one of very few groups which did.

Now the commonality principle, as Hurst * calls this phenomenon, is hard to prove. There are so many stocks to be studied and so many factors involved that the task is endless. We believe you will see in this section, however, that the relationship is clearly demonstrated by the movements of the advances and declines moving totals and their correspondence with the Dow average and with buy-sell volume totals.

The next time someone tells you about a wonderful stock in a bull market, ask him for some more names. If he only knows one stock he hasn't done his homework—there are plenty of wonderful stocks in a bull market.

The advances totals correspond closely to the Dow average

Now that we know how moving totals are constructed, let's see what they reveal when we plot the totals on a chart. In Fig. 4.8, we have plotted the end-formed, five-day moving totals of advances and declines and of buying and selling volume for 1970 in separate curves in the top portion of the chart, 25-day, end-formed moving totals of the

* J. M. Hurst, *The Profit Magic of Stock Transaction Timing*, Prentice-Hall, Inc., Englewood Cliffs, N.J., 1970.



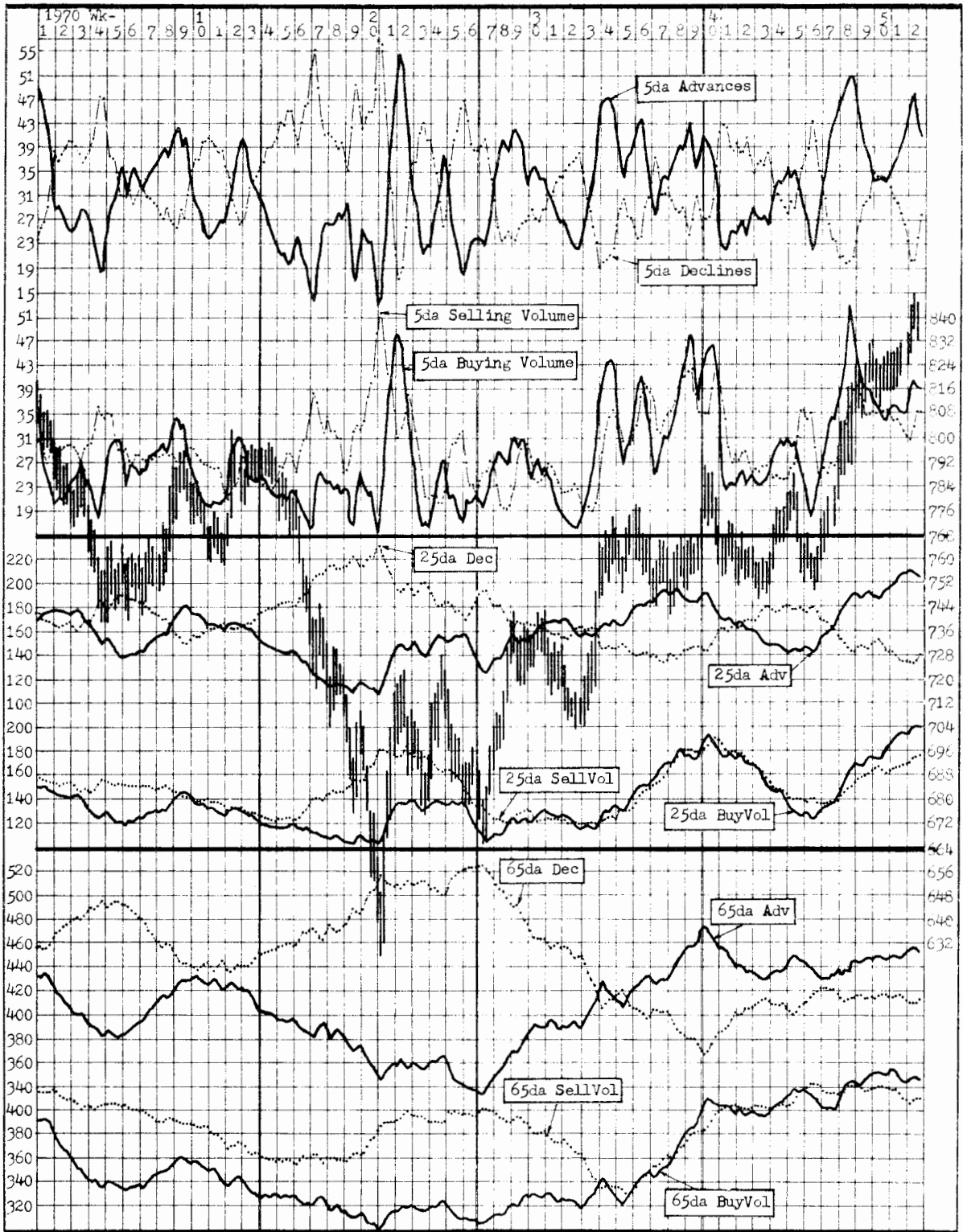

Fig. 4.8—The relationship of the opposed couples of cyclical elements in five-day, 25-day and 65-day moving totals and of the Dow average.

same elements in the center portion and 65-day, end-formed moving totals in the lower portion. This gives us a chance to see how the totals operate and get some sort of idea of how cycles are generated, since these are the four basic elements in the market.

The first thing we notice is that the advance and decline totals move oppositely from each other. That is, when the total of advances is increasing, the total of declines is decreasing, so that the two totals oscillate and alternate across the point of equilibrium. The short totals swing in short movements which sometimes last about 10 days and sometimes several weeks. The longer totals are more leisurely and swing over longer periods, with less amplitude in the swings but with more time involved in the period from equilibrium to equilibrium.

The second thing we notice is that the volume totals move quite differently than the A-D totals, in that the volume totals tend to parallel each other. Here also, however, the shortest totals move with great amplitude in short timespans, while the longer totals move in a more leisurely fashion and remain separated for longer and longer periods as the length of the total increases.

For background in the illustration, we have plotted the bars of the Dow industrial average high-and-low figures for each day. When we look closely, we see that the movement of the DJI is closely related to the movement of the five-day advances total. That is, when the five-day total moves upward, the Dow is inclined to follow. The correlation is not perfect but the tendency is present. For instance, in weeks 4 to 9, the advances total rose quickly from about 1900 to 3500, went sideways for about a week and then moved on upward to a high of about 4300. The Dow, on the other hand, lagged in the first part of the move, continued sideways until the beginning of the eighth week and then spurred from about 760 to nearly 800. While the market was falling from the 13th week to the 21st week, the five-day advances index declined to about 1500 stocks and went mostly sideways until the decline of the Dow was over. Equilibrium between the two short totals was not reached until the middle of the 21st week, when the Dow started its rebound from the lows.

The longer totals also reflect this movement. That is, the 25-day advances total hit a low of 14,000 in the fifth week, rose above equilibrium to peak in the ninth week and then moved down to a low which coincided with the Dow's low in the 21st week. The 65-day totals followed much the same course, except that the 21st week low was exceeded in the 26th week. We can see from the chart, then, that there is a correspondence between the movement of the Dow average and the totals of advances. That is, when more stocks are declining than advancing, the Dow moves downward, and when more stocks are advancing, the Dow is advancing.

Volume totals remain closely balanced, except in large, fast downswings

When we look at the longer volume totals in the chart, we see first that there appears to be a tendency for them to trace a pattern somewhat similar to the A-D patterns. That is, in the large drop of the Dow to the 21st week, the long-term volume totals tended to separate with selling in dominance, and the longer the total, the greater the separation. For instance, while the 25-day totals reached equilibrium in the ninth week, the 65-day totals remained widely separated. On the other hand, during this



period, the short five-day totals of volume alternated between buying and selling as the Dow moved up and down, and a wide separation of the two totals came only in the weeks during which the Dow was dropping rapidly.

We also can see from the five-day volume totals that whole volume, or the combination of the two totals, remained fairly constant until the 15th week, but, beginning at this time, volume built up with a large preponderance of selling during the entire drop of the Dow. On the longer totals, however, we can see that whole volume was declining until about this time. That is, while the Dow was declining, overall volume in the market was declining also, as revealed by the longer-term indicators.

After the Dow bottomed at about 630 in the 21st week, on a huge buildup of selling volume, we would expect that most of the selling would be over. Not so, however, as revealed by the five-day totals. As the dotted line indicates, selling continued strong for a period of about six weeks. For the longer totals, the 25-day buying volume curve reached equilibrium with selling in the 28th week, and, from then until the end of the year, while the Dow was moving from 630 to 840, the two totals alternated in dominance, with buying slightly ahead on the rise to the 40th week and selling slightly ahead until the end of the 47th week. The same tendencies are apparent in the 65-day volume totals.

What we learn from the illustration is that in a down market selling can become a massive figure, but in an upward market the ratio of buying to selling is quite close, regardless of the length of the moving total. We can see, thus, that there is a tendency for the two parts of volume to remain closely balanced, except in a downward market; whereas, there is a tendency for the advance-decline totals to separate. This occurs because of the universe of stocks in the market. That is, when stocks are advancing, the tendency is for more stocks to move upward with a consequent decline in the number of stocks moving down. Volume, on the other hand, since it oscillates in quantity, is more likely to remain closer to a balance, except in a large decline. Now, as we shall see, the tendencies of the two couples of opposed forces in the market are the reason for cycles in the market. A-D totals have a tendency to separate—volume totals have a tendency to remain close, except in a real decline of the Dow. It is these two tendencies which underlie cyclical oscillations.

Buying causes stocks to advance; increased prices cause selling

It is also obvious from Fig. 4.8 that the longer-term, end-formed volume totals tended to carry beyond the bottom of the market in the 21st week, and also beyond the cyclical trough which occurred in the 27th week. Part of the reason for this is the carryover which is inherent in moving totals and part of it derives from the tendency of volume to balance between buying and selling, so that excesses are slow to be corrected. Also there is the fact that volume, once expended, is likely to be gone for a long period of time. That is, as we saw in Chapter 2, stock purchase and anticipation of gains are parallel. When stock is bought, it is bought with anticipation of a profit from a later sale. Once a purchase is made, therefore, it takes time for that stock to reappear in the market. This is especially true when a stock declines after purchase so that the purchaser is “locked in” to a loss.



It follows, therefore, that short totals of volume are the most usable for the market student. As we can see in the chart, the 25-day totals continued to show selling as dominant until the beginning of the 30th week, and the 65-day total showed selling dominant until the beginning of the 36th week. While this tendency also was present in the five-day totals, we can see that the buying volume curve increased tremendously from the bottoming of the Dow in the 21st week, and also to a lesser extent in the 27th week.

A more normal relationship of the five-day buying totals is seen in the 33rd–34th weeks. Volume increased from a low in the 32nd week, and the market, as measured by the advances total, increased sharply. In this case, buying led the movement as the buying volume total increased ahead of the selling total. As usual, however, as prices increased, selling also increased, so that by the beginning of the 35th week, buying and selling reached an equilibrium. The same sort of occurrence came in the 46th week, and, as we can see, the movement of the A-Ds and the buying volume total preceded the movement of the DJI by several days. From the track of the advances total and from the buying volume total, then, we can see that it requires volume for stocks to advance in price—increased buying causes stocks to advance and price increases cause selling volume to increase.

The price-volume relationship is not a fixed ratio

Despite the carryover tendencies of our indicators in Fig. 4.8, we see that at times the relationship of price and volume is quite close, and, at others, the relationship indicates something is changed. For instance, in the rebound from the low in the 21st and 22nd weeks, we find that the amplitude of the upswings of the five-day advances line and that of the Dow average were nearly identical on these scales. Also, we can see that the amplitude of the swing of buying volume was almost the same as those of the five-day advances and the Dow. In other words, there was a good relationship between the three measurements, so that the Dow and the advances line were close to a 1-to-1 relationship, and this relationship also existed between the advances and the Dow.

At other times, we see that this 1-to-1 relationship does not hold. For instance, in weeks 4–9, the five-day advances curve advanced sharply, the buying volume curve also moved, but less sharply and the Dow hardly moved, except in the final week. The relationship was also strained in the upsurge from weeks 27–32. Here the Dow moved much faster than the advances curve and considerably faster than the buying volume curve. On the downswing, in weeks 29–32, the five-day advances curve moved the farthest and the Dow curve and the buying volume curve were about equal in amplitude. Later in the year, in weeks 32–41, we see the correlation between the buying volume and the advances curves was close while the Dow did not genuinely reflect the movements of the other two curves.

It is obvious, then, that the relationship of the Dow's price, advances and volume is not a rigid one. That is, the Dow average does not always reflect accurately the movements of underlying market forces, as we gauge them, since sometimes, in comparison, the Dow moves fast and sometimes slowly. This is illustrated in Fig. 4.9, which shows, in the next to the bottom portion of the chart, the velocity rate of the Dow movements. As we can see, the velocity of the price change of the Dow was greatest in the period



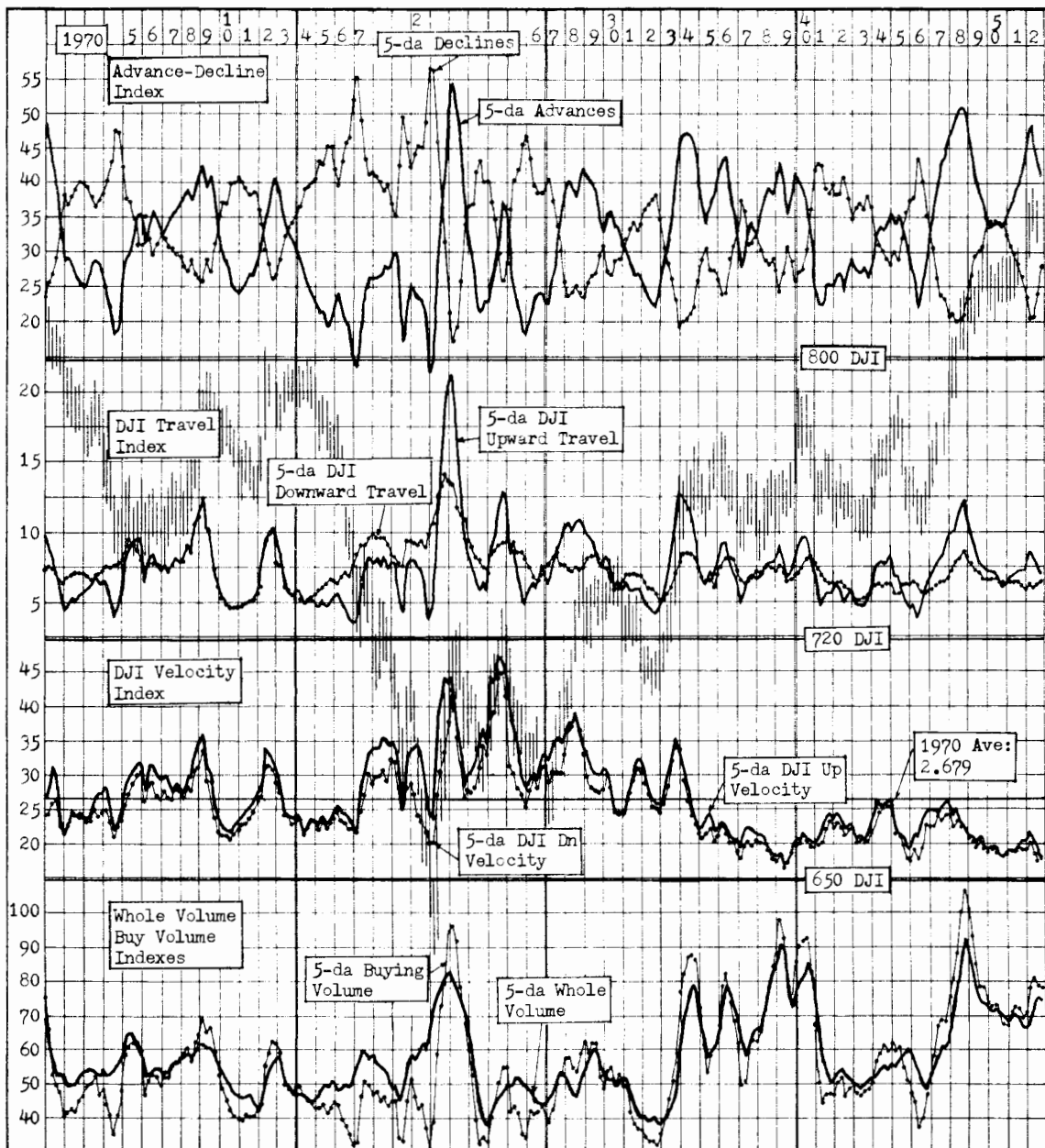

Fig. 4.9—The relationships of advances, the Dow industrial average and volume and buying volume show a variable correlation.

from the 17th week to the 33rd week and was low in the week 14–17 period, and lower still in the 34th–41st week period.

Before we go into the velocity portion of the chart, however, let us look first at the two upper areas of the illustration. The top portion contains the five-day advances curve, together with the declines, and in the second part we have plotted five-day moving totals of the upward movement of the Dow average, which we obtained earlier, and also five-day moving totals of the downward movement of the Dow. Since these

are, once again, moving totals, they are subject to the lag limitations of moving totals, but, since these are short, they give a good portrayal of conditions during 1970.

When we look at the chart, we see first that there is a good correlation between the advances curve and the DJI upward travel curve. That is, when the advances curve moved upward, the Dow curve also moved upward, generally at a reduced rate, so that the DJI travel curves appear to be a reduced or “dampened” version of the A-D curves. Second, we see that, similarly to the volume curves, the two Dow curves tend to remain close to each other—in other words, they do not separate, except when there are fairly violent movements of the average. For instance, the plots of the two curves are almost identical in the period from week 1 to week 14, although there was a tendency for the downward curve to move higher than the upward curve in the first few weeks. The same sort of performance was repeated in weeks 34 to 46 when the Dow was moving mostly sideways. We find, then, from our plots, that it is the tendency of the two Dow totals to remain fairly close, or to express a relationship in which there is nearly always, except in very rough times, a close balance between upward Dow movement and downward Dow movement.

The important thing here, however, is the good correlation between movements of the A-Ds and the Dow average. When the two are plotted from values assembled by identical methods, the differences between them are only a matter of degree. That is, except for degree, the 30 Dow stocks exhibit the same tendencies to move as all stocks on the NYSE. The principal difference is that, because of their universe, the A-D totals tend to separate while the Dow movements remain closely balanced. We can see, then, that by using the Dow ratio for breaking down volume and the A-Ds for expressing price, our calculations for both parts of the equation are nearly equal—or in a 1-to-1 relationship.

The DJI velocity index defines the price-volume relationship

In the lower portion of the chart, we have plotted the movement of whole volume, also in a five-day total, and, at half scale, the movement of buying volume. Here, too, we have a close correlation between the two curves, which indicates that most of the time buying volume is about one-half of the volume total. This, of course, is as it should be since the breaking ratio for volume derives from the travel of the Dow average, so that, if the five-day total of upward movement is greater than the five-day total of downward movement, the five-day total of buying volume should be greater than that of selling volume. In other words, it stands to reason that the two parts of volume should have the same relationship as the two parts of price movement. If this is true, then, we should get the same relationship when we divide the Dow’s price movements by volume, or, simply, if the price-volume relationship was constant, we would always arrive at an exact amount of travel which a given quantity of volume should generate. Unfortunately, however, the Dow shifts gears.

For example, the paths traced by our velocity indexes (the solid line is upward velocity and the dotted line is downward velocity) indicate that sometimes the Dow moved 4.5 points and sometimes less than 2.0 points on an equivalent amount of volume. The velocity index is constructed by dividing the five-day total of each of the



Dow price movements by the equivalent five-day total of NYSE volume. If the relationship was always constant between each of the two parts of the equation, the Dow would move an average of 2.68 points for each million shares of stock traded, since that is the average figure for the year.

For instance, during the first few weeks of the year, the velocity indexes were oscillating slightly above and slightly below the yearly average, indicated by the heavy horizontal line. The drop in the Dow average price the ninth through the 11th weeks was less severe than others in the chart because the velocity of movement of the Dow decreased from 3.5 points per million to almost 2.0 points per million shares.

The opposite was true in the following weeks (11–12), but then the velocity declined to another low beginning with week 14, which remained constant until the Dow broke through the 720 support zone in the 18th week. From this point, which was a 10-week cyclical low, velocity increased rapidly, and upward velocity outpaced downward velocity despite the downswing of the Dow. When the Dow was dropping so rapidly, how could upward velocity actually exceed downward velocity?

The answer is in the extreme volatility of bear market rallies and in the relationship of velocity and volume. In bear rallies, shorts (persons who have sold stock they don't own in the hope of buying it back at a lower price) have little choice when a rally starts. There isn't time to decide whether a rally is genuine, since every point upward means a loss or decreased profits, so shorts "cover" their deficiencies at market prices and prices move rapidly upward under the pressure of buying—at any price.

Conversely, the period between the 34th week and the 46th week of 1970 was a dull one in the market, despite the tremendous volume which was generated. The Dow moved from a low of just above 740 to a high of 790 but spent most of its time between 750 and 770. Volume, on the other hand, reached proportions which actually exceeded the high in the 23rd week of the year, and the volume was sustained throughout the period, with three minor dips. From the velocity indexes, we can see that the reason for the lack of movement in the Dow was, simply, that the Dow was in low gear at the time. That is, despite the high volume, the Dow was moving between 1.5 and 2.5 points per million shares, as opposed to the 4.7 point movement evident earlier.

As we have seen in Figs. 4.8 and 4.9, all of the indicators we have constructed, the A-D totals, the DJI price movement totals and the buying-and-selling volume totals, exhibit a tendency to move in unison, and the tendency differs only in degree of movement since the timing of all forces is identical. What we are seeing is cyclical force at work in the market, and, from the illustration, we can also see that the alternation of force is continuous.

Cycles derive from the balance of price-volume relationships

From Fig. 4.9 we see that during 1970 the swings of the five-day indicators, particularly the A-Ds, sometimes encompassed periods considerably longer than 10 days. For instance, in the period from weeks 13 to 21 the declines were dominant and continued their dominance until the Dow reached a bottom at about 632. At later times, the advances remained dominant for three and four weeks at a stretch, despite the attempts of the declines total to reach equilibrium.



Now from the swings of the short totals, it may occur to some of us to question the validity of the 10-day cycle. Close examination of the five-day advances total, however, reveals that there is a 10-day tendency. For instance, in the upswing movement of the 32nd–41st weeks, the advances total pulled back in the 35th week—13 days from the previous trough, pulled below the point of equilibrium in the 37th week—nine days from the previous low, pulled down from the high in the 39th week—12 days from the previous low and again in the 41st week—eight days from the previous low. The period covered, thus, was 42 days—or an average of $10\frac{1}{2}$ days—and the A-D movements were corroborated by the movements of the other indicators.

Since we can find evidence of a 10-day swing of opposed price forces, perhaps we can also see evidence of longer cycles in Fig. 4.8. Here, however, the tracks are more obscure since, while the 25-day total averaged about nine weeks in the four full swings on the chart, the visible recognition of cyclical swings is difficult. That is, the 25-day advances total hit a low in the 21st week and another low, in comparison to the declines total, in the 44th week—or a timespan of about 23 weeks. The volume totals roughly paralleled the movement of the advances curve so it would appear, if we didn't know better, that they might be measuring off a 25-week cycle instead of a 10-week cycle. We can, in fact, find little evidence from the four totals that there really is a 10-week rhythm working in the market. The 65-day totals are equally discouraging when we try to locate the 25-week cycle in the market.

It is evident, however, from the swings of the opposed forces in even the longer moving totals that there is a rhythmic tendency in the market, and we can conclude from the five-day totals that there is a tendency for the rhythms to be regular except for outside interference. That is, if the original beat of the small input cycles is regular, it follows that the rhythms of larger multiple cycles will also be regular, except for outside disturbances. It is also apparent, however, that we cannot measure cycles from the moving totals of the two basic couples of forces in the market. Something is escaping our view.

The missing element is the final relationship in the cyclical equation. We have, with our moving totals, set up the basic relationships of the opposed forces, but we have yet to balance the forces. That is, cyclical movements are generated by the balance of price movements and by the balance of volume movements, but the real rhythms of the market arise from the reaction of price to volume balance. What is remaining, then, is to divide the A-D ratios by volume ratios and to plot the resulting TORQUE factors.

V—How Cycles Are Revealed by the Price-Volume Relationship

In previous parts of this chapter, we have learned how to gather the vital statistics of cycles and how to set the statistics up in order to visualize the cycles. Now it is time to see how the final step in cycle calculation operates and what it reveals.

In Fig. 4.10, we show what happens when we divide our moving advances and declines totals by the totals of buying and selling volume. In the figure, the ratio between advances and declines is indicated by the light solid line and the ratio between



buying and selling volume is indicated by the dotted line. In arriving at these ratios, as we remember, we always divide the quantity of advances by the quantity of declines and the quantity of buying volume by the quantity of selling volume, so that a ratio above 1.0 indicates more advances and more buying volume than their opposites. The final line of the figure, the heavy solid line, indicates the resultant curve from the price-volume relationship, or the TORQUE values for the cycles involved. For reference, these are all displayed against the background of the Dow average.

The first thing we note in the drawing is that price, as portrayed by the A-D ratio, tends to swing much wider than the volume ratio. That is, at the peaks, the price curve is always well above the volume curve—the two strike a balance somewhere in the middle—and, at troughs, the price curve is always well below the volume curve in the figure.

We also can see quite plainly that the difference we noted earlier between the volume moving total curves and the price curves also holds in the ratios. That is, the volume curves tend to separate like the price curves in a down market, but in an upward market, the buy-sell curves remain close together, so that, as a rise progresses, the ratio between the two tends to oscillate around 100—or the balance between the curves.

From the drawing, we can see that the cycles result largely from the price ratio but that it is really the difference in response between the two curves that shapes the cycles. For instance, we noted earlier that the 10-week cycle started upward while the Dow was still declining in the second quarter of 1970. From the chart, we can see that the cycle (heavy line) reached its trough in the 18th week and that the reason the cycle started upward from that point was that the separation between falling price and falling volume reached its extreme at that point. The widest separation between the two curves came in the 18th week, and from there the price decline tapered off in velocity while the volume curve continued at about the same rate of descent.

At the cyclical trough of the market in mid-1970, the ratio between advances and declines in the 25-week cycle reached a low of 64% in the 27th week. Volume balance, on the other hand, troughed at 76%. Dividing 64 by 76 gives a result of 84% so that even though price was considerably below that point, the volume ratio raised the cyclical value, since 64% is 84% of 76%. Balancing volume against price—which tends to swing wide at peaks and troughs—brings us the true strength of the cycle involved.

How the five cycles defined the 1970 trough

In Fig. 4.11, we have made the calculations (dividing price by volume for the year 1970) for all five of the cycles in our cyclical chord. The first thing which is evident in this drawing is that the tracks of the TORQUE values of all the cycles closely resemble the tracks of the advances totals. That is, the two-week rhythm closely relates to the five-day advances total (Fig. 4.8), the 10-week rhythm has a close resemblance to the 25-day advances curve and the 25-week rhythm matches the swings of the 65-day advances curve.

The rhythms, however, are not an exact match, since they are the result of the



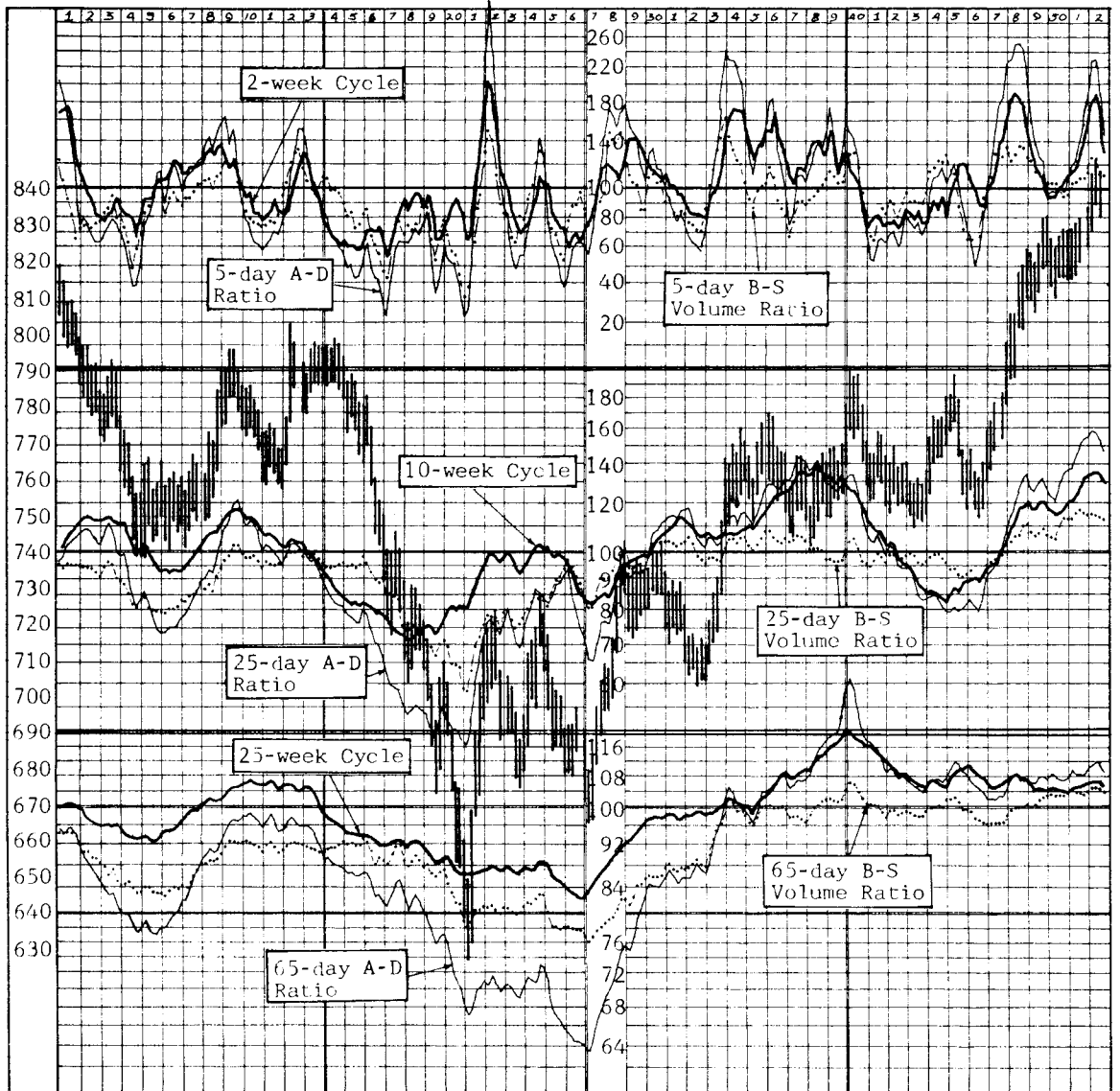

Fig. 4.10—The division of the price factor by the volume factor brings out the TORQUE relationships in cycles in the market.

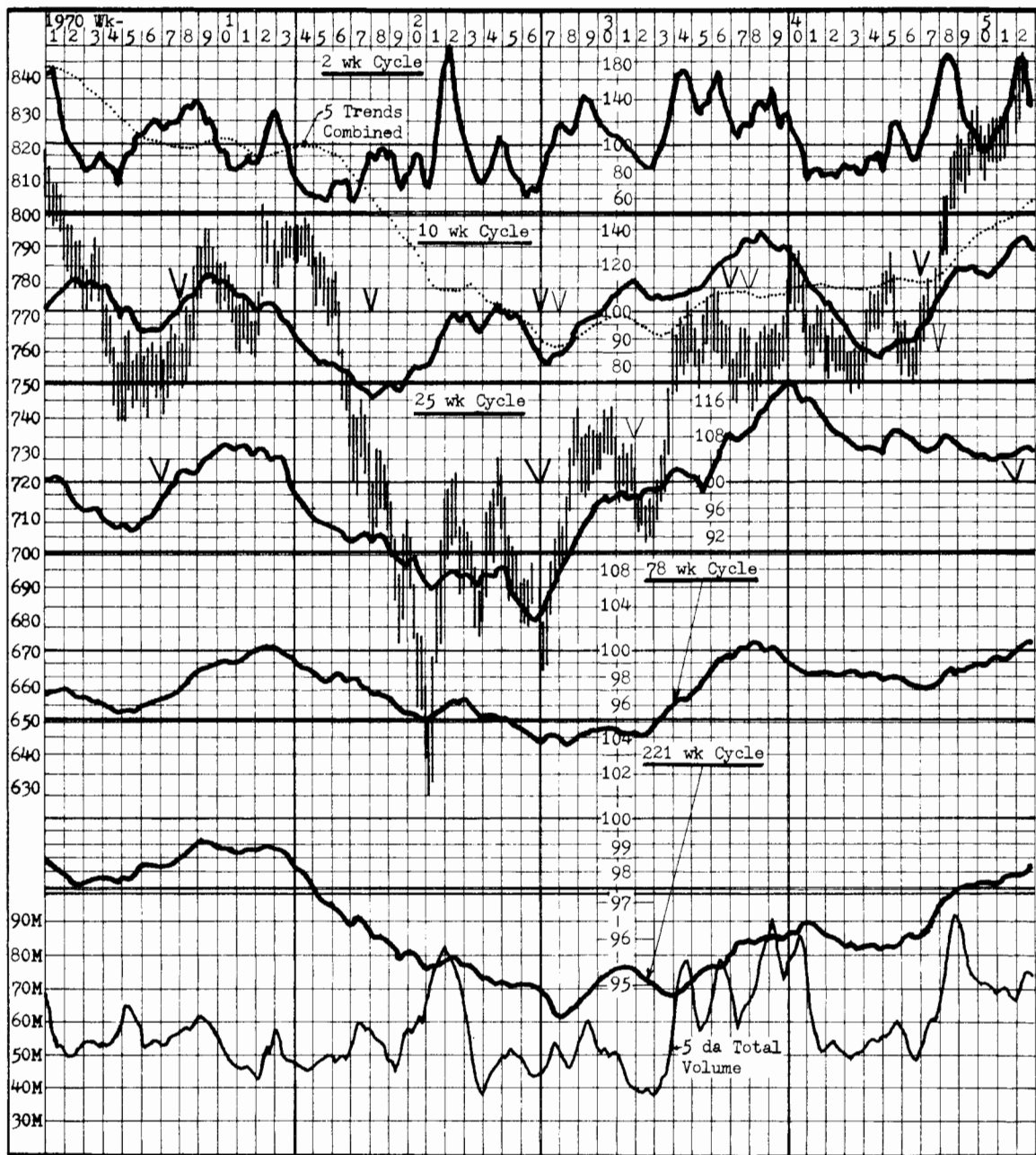

Fig. 4.11—The movement of each of the five cycles during 1970.

division of the A-D factors by the volume factors. At times, then, there is a considerable difference between the two. For instance, we see that the trough of the 10-week cycle rhythm in Fig. 4.10 came at the beginning of the 18th week. The advances curve, however, did not trough until the beginning of the 21st week. The cycle troughed again in the 27th week—or nine weeks from the previous trough—while the 27th week low in the advances total was only 6½ weeks from the 21st week low.

It is apparent, then, that there is more to market cycles than price—volume also plays a big part in the rhythmic movements of the cycles. It is also apparent that we are really much closer to finding the rhythms in the market when we subject the forces to the final calculation. For instance, we can see that the 10-week rhythm was actually moving up during the final drop of the Dow to 630. We can also see that the cyclical bottom of the market came, not in the 21st week as most people assume, but in the 26th–28th weeks—because all of the five cycles troughed at this time. That is, the two-week cycle troughed in the 25th week, the 10-week cycle troughed in the 27th week, the 25-week cycle troughed in the 26th week, the 78-week cycle troughed in the 28th week and the 221-week cycle troughed at the end of the 27th week.

In other words, there was a consensus of cycles that the trough of the market occurred in the 26th–28th week period, which is not especially remarkable if we consider that cycles are harmonious or that their lengths are multiples of the basic cycles. The real troughs of the market, then, occur when there is a combination of cycles troughing at one time. At the turn of the 1970 cyclical bottom, all the cycles were in unison on the upside—and the same thing happened at the October 1966 trough of the market. At times like these, it is as though a giant hand stops all the cycles and readjusts their phases so that they all start off again together.

How the chord of cycles acted in the 1966–70 swing of the 221-week cycle

In order that we may see the swings of the longer cycles in the market, we have constructed cyclical rhythm charts for the years 1966 through 1970. These charts, Figs. 4.11–4.15, illustrate on a daily basis the movements of the DJI as a background for the swings of the cyclical influences. During a span of five years, we have room for ten swings of the 25-week cycle, three swings of the 78-week cycle and one swing of the 221-week cycle. This should be adequate to give us a picture of what happens when the market average swings upward from the October 1966 low of 735.75 to the December 1968 high of 994.56 and then to the July 1970 low of 665.32. We are ignoring, you will note, the May 1970 low of 627.46, since this event was not, as we have seen, a cyclical low but the result of a random event. That is, there is no cycle which repeats from the May low, and, as we know, a cycle implies that an event has recurred at sufficiently regular intervals to be significant.

To begin with, let us look at the swing of the 221-week cycle during this five-year period, since this was the dominant cycle of the period. The 221-week cycle hit a low of about 98 in the 41st week of 1966, and from this low it moved upward to 102 in the 32nd week of 1967. From here it dipped to a low of 100 in the first quarter of 1968 and then continued to rise until the 41st week of 1968, topping out at about 105.5



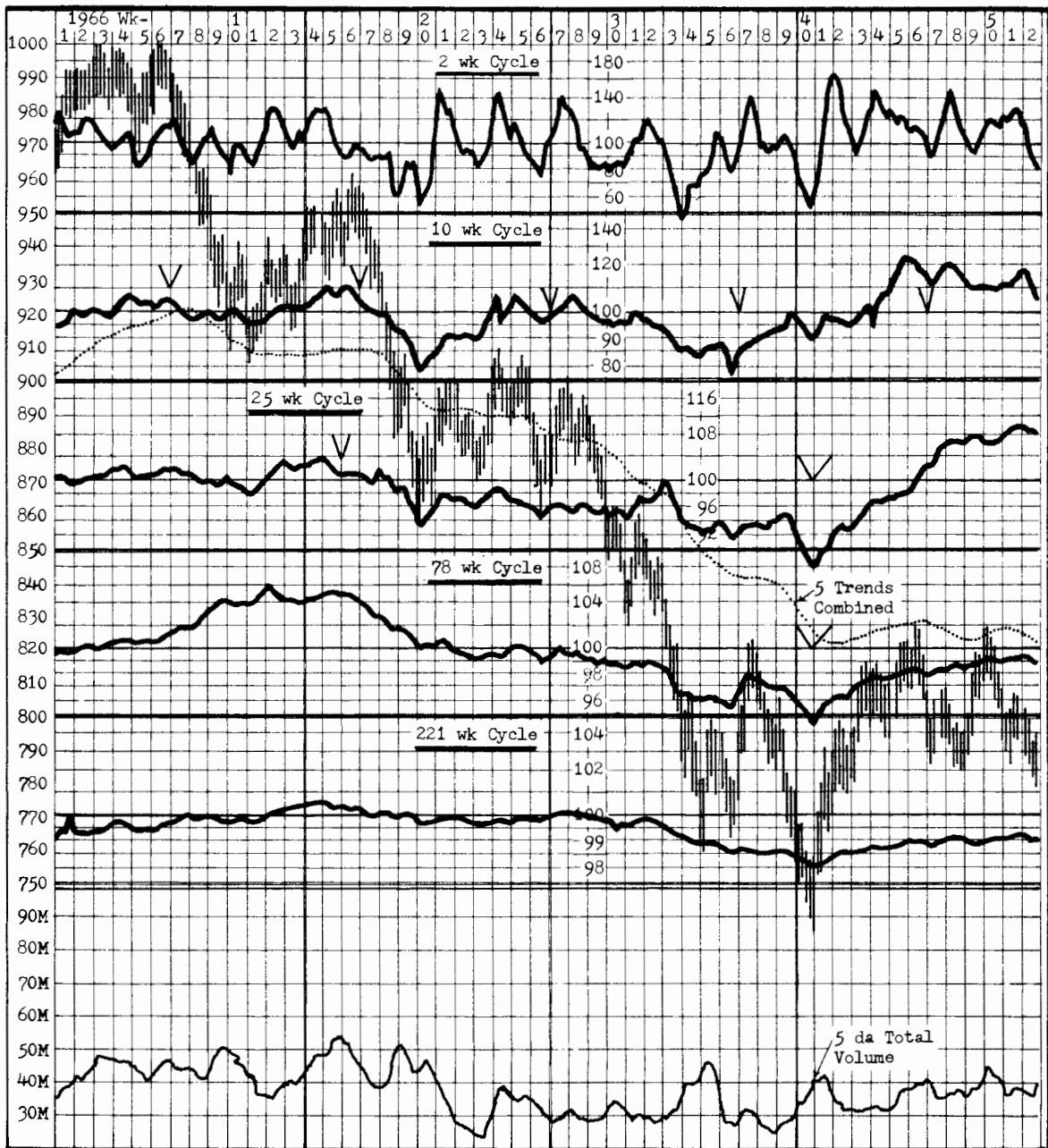

Fig. 4.12—The movement of each of the five cycles during 1966.

just previous to the actual market top in December of that year. From here, the trend of the cycle was down, with a low of about 97½ in the 31st week of 1969, a rally up to 99.5 in November of 1969 and the final decline to the July 1970 low of about 94.5.

This span covered 15 quarters or exactly 195 weeks in total. It is to be noted that the cycle started in the 41st week of 1966 and ended in the 26th week of 1970. Since there were 53 weeks in the 1969 calendar, the swing was exactly 15 quarters long or 26 weeks short of its expected low. At the July 1970 low, then, the 221-week cycle was six months or two quarters ahead of its expected timing—or 13 weeks out of synchronization with its ideal timing, if we use the June 1949 low as the starting point. It has, thus, overadjusted for the three-month delay in 1957.

That is, the first fully evident trough of the 221-week cycle occurred in 1949 and the second trough came in September 1953, or precisely 4¼ years after the first trough. The next trough occurred in October 1957 or roughly four years later. From the October 1957 low until April 1958, the cycle went sideways, as we saw in Fig. 1.12, so that the next trough in June 1962 was three months late in its timing from the October 1957 low. In the next revolution, the cycle again took its full 4¼ years to trough, hitting a low in October 1966.

If the timing of each of the cycles had been perfect, the troughs would have come in June 1949, October 1953, January 1958 (instead of October), March 1962 (instead of June), June 1966 (instead of October) and October 1970 (instead of July). Since we cannot guess whether the next swing of the cycle will get back to perfect synchronization, we must project that the next cyclical low of the 221-week cycle will come in October 1974. Since this has been a regular observable cycle since the end of World War II, we can assume that it will continue to beat with regularity.

The second largest cycle in the illustrations is the 78-week cycle which encompasses six quarters or a year and a half. This cycle also has been quite regular in its movements, except for the 1969–70 version, since it troughed in consonance with the 221-week cycle in the 41st week of 1966 and at 98 in the 14th week of 1968—a timespan of almost exactly 78 weeks—and again at 92 in the 36th week of 1969—a timespan of 74 weeks. The final version of the 78-week cycle broke down into a 37-week period, troughing at 93.5 in the 27th week of 1970. The new mechanical timing for this cycle, then, would extend 78 weeks from the 1970 trough. (The cycle actually troughed in the 47th week of 1971—72 weeks from the beginning.) Since it also has been regular in its performance, in the versions we can see, we can assume that it will continue. Also assuming that this cycle was on time when it hit bottom in 1966, we have placed downward Vs at the ideal timing points for the troughs and upward Vs at the ideal timing for the peaks. The first trough came in 1966 and a peak in the cycle followed exactly on schedule in the 27th week of 1967. The following trough was also on time, in the 14th week of 1968, the following peak in the cycle came in the 48th week of 1968 (instead of week 1 of 1969) and the following trough was also ahead of schedule in the 36th week of 1969 (instead of week 41). Now we notice that the DJI bottomed at the October 1966 low, rallied 11 weeks after the cyclical top in week 27 of 1967 and hit bottom two weeks earlier than the ideal timing in week 14 of 1968. In the next



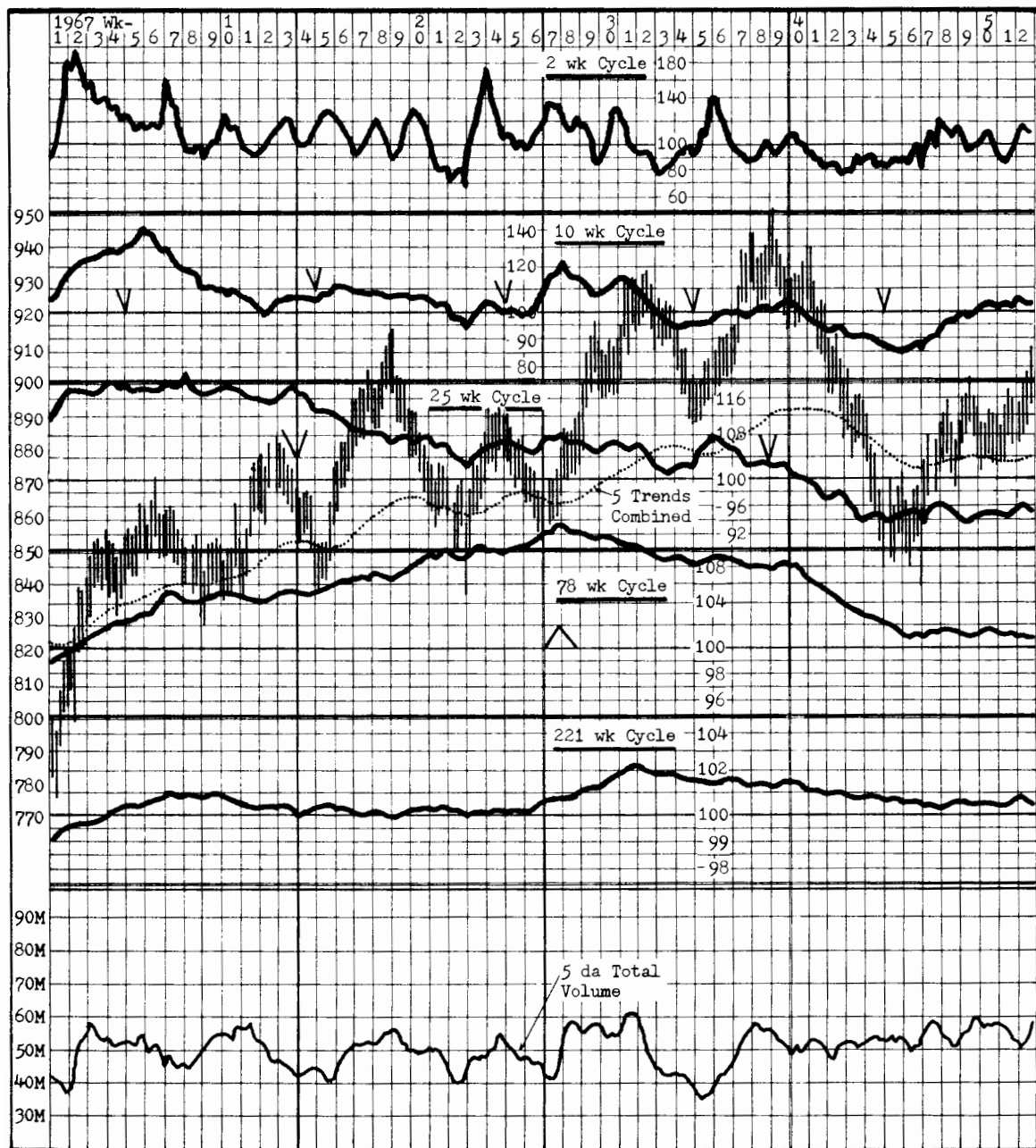

Fig. 4.13—The movement of each of the five cycles during 1967.

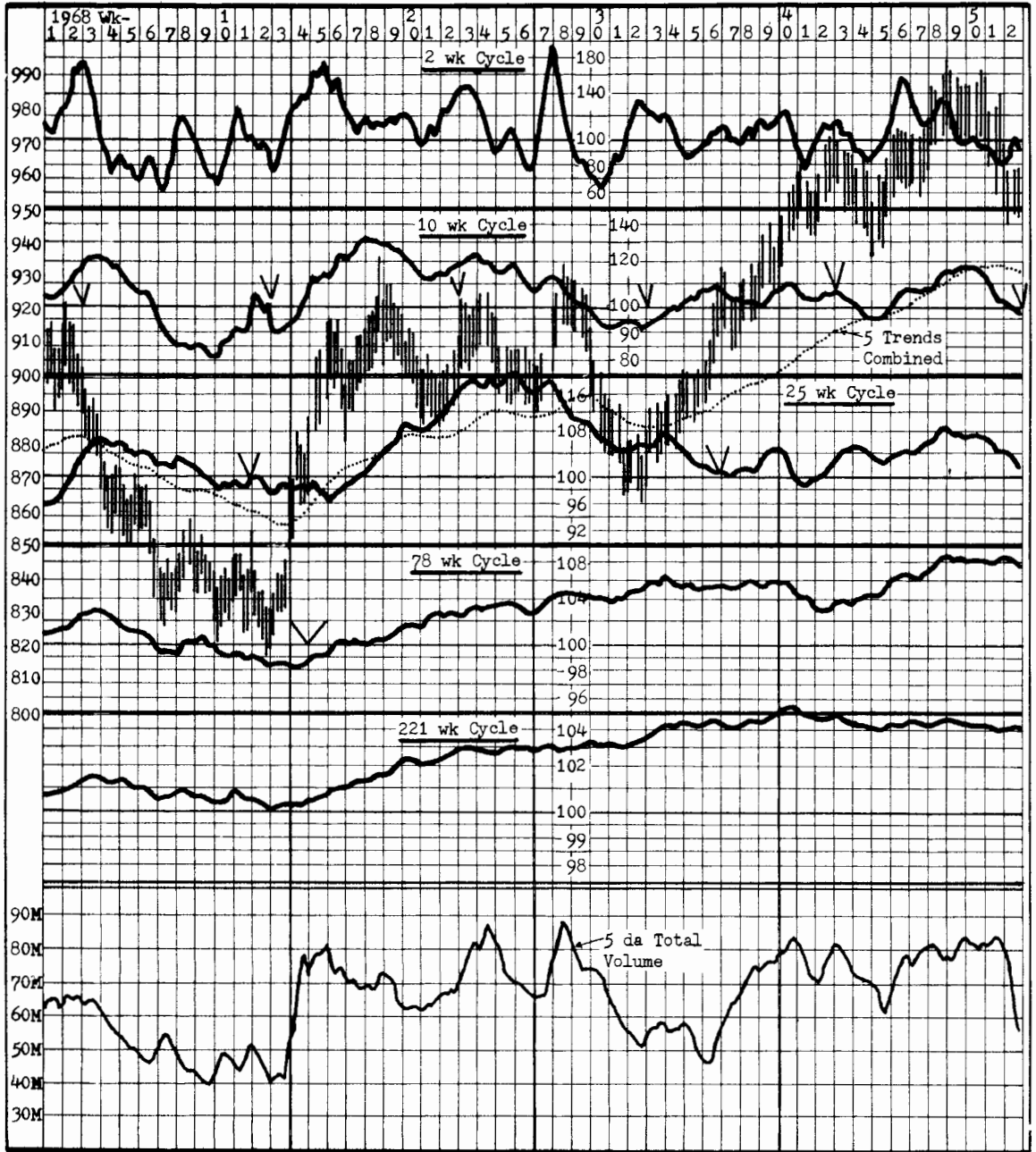

Fig. 4.14—The movement of each of the five cycles during 1968.

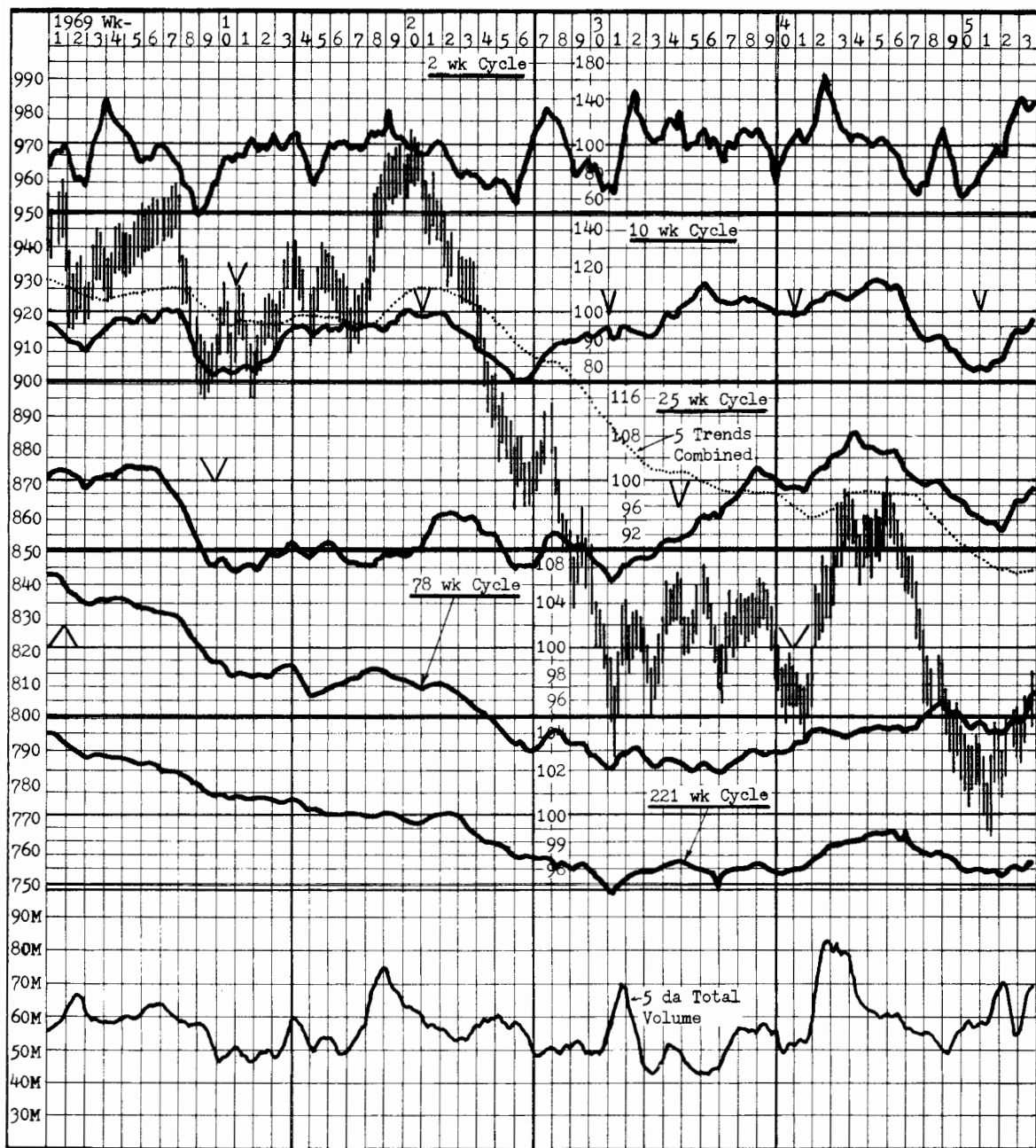

Fig. 4.15—The movement of each of the five cycles during 1969.

version, the Dow topped out in the 49th week of 1968 (in timing with the actual cyclical top, which was early) and bottomed five weeks later than the cycle in week 41 of 1969.

The movements of the small cycles vs. the large cycles

When we get to the smaller cycles in our five-cycle chord, we find a picture which is quite different from that portrayed by the longer cycles. That is, the smaller cycles are more subject to distortion by the longer cycles than the longer cycles are by changes in the smaller cycles. For instance, from the 1966 low, the upswing of the 78-week cycle carried the 25-week cycle from a low of about 88 to a high of about 123 in the eighth week of 1967—or some seven weeks beyond the ideal peak of the cycle. From the first quarter of 1967, the 25-week cycle was unable to return to the point of equilibrium at 100 until well after the 78-week cycle had peaked in the 27th week of 1967, a classic example of the struggle of a shorter cycle to decline in the face of rising strength of a longer cycle. Similarly, during the final quarter of 1967, the downward trend of the 78-week cycle kept the 25-week cycle from having its normal upswing, with the result that the cycle was able to advance only in the first weeks of 1968 when the 78-week cycle also moved upward.

The upward movement of the 78-week cycle started three weeks after the trough of the 25-week cycle in the 12th week of 1968, with the result that stock prices of the 30 Dow rose spectacularly from about 820 to a high of about 920 at the 25-week cycle peak in week 25 of 1968. In the final quarter of 1968, the rally in the Dow was the result of the upward movement of the 25-week cycle and the upward push of the 78-week and 221-week cycles. Looking at the chart, we see that the DJI movement from the low in week 32 got started by the action of the 10-week cycle, dipped with the 25-week cycle in week 37, continued upward to the peak of the 221-week cycle in week 40, dipped with the 10-week cycle to week 45 and made its final peak under the influence of the 25- and 78-week cycles in week 48. The final peak of the market, thus, was the result of the varying influences of all four of the longer cycles in the chord.

In the downward phase of the 1969–70 markets, we can see that the rally peak in the 20th week of 1969 was the result of the combination of the upward forces of the 10-week and 25-week cycles, that the sharp drop came when both cycles turned down and that the triangle and rise in the third and fourth quarters were the result of all four cycles pushing upward. In the final drop of the averages to the July 1970 low, we can see that the random selloff in the middle of the second quarter was really not a cyclical affair at all. For instance, the 10-week cycle bottomed on its ideal schedule at the end of the 17th week, rose upward to the point of equilibrium and troughed again in week 27. This cycle, certainly, contributed nothing to the margin selloff. The 25-week cycle did not hit its low until the end of the 26th week of the year and the 78-week cycle did not bottom until the 28th week, with the 221-week cycle hitting a trough at the end of the 27th week. In the consequent pullup during the third quarter of 1970, all cycles were pulling together on the upside so that the 120-point movement from about 670 to 790 was a pure cyclical event. The final thrust of the Dow in the year came when the combined influence of the 221-week, the 78-week and the 10-week cycle pointed upward—against the troughing influence of the 25-week cycle.

In this portion of the charts, it will be noticed that we have installed both heavy



and light ideal nadir marks for the 10-week and 25-week cycles. The heavy marks assume that the July 1970 trough of the Dow was sufficiently accurate in synchronizing the cyclical influences, that it marked the start of a new ballgame.

The light marks indicate the timing that was left over from the previous 4¼-year swing. That is, at the October 1966 low, the three largest cycles were in synchronization when they troughed. Using this as a starting point, then, the ideal timing of the troughs was marked on the charts. That is, the first trough of the 25-week cycle is marked 25 weeks from the October low and the second is 50 weeks from the low. Since the timing of the 221-week cycle was off schedule by 26 weeks—or 13 weeks if the 1949 low was on time—it is obvious that a new timing schedule has been set up for the market. That is, a whole new series of timings for each cycle was begun when the market bottomed at the beginning of the 27th week of 1970. The validity of this assumption can be seen in the peaking of the 25-week cycle just 13 weeks after the trough and in the troughing of the 10-week cycle 18 weeks after the July low.

Now we can see from the charts, that, except where there is a tendency to trough short or to break down into harmonic lengths, the longer cycles are the more regular cycles and the shorter cycles are more erratic. That is, in the 11 versions of the 25-week cycle which are visible in the charts, the 25-week cycle can be said to have troughed on time only about eight times. It missed troughing in the 16th week of 1966, in the 13th week and again in the 38th week of 1967. The 10-week cycle was even more erratic on an “ideal” basis, but we can see that the 10-week cycle, despite its “ideal” irregularity, had more effect on the Dow average than the other cycles. That is, the troughs of the 10-week cycle coincided almost exactly with Dow troughs in weeks 37, 1966; 15, 1967; 35, 1967; 44, 1967; 12, 1968; 33, 1968; 31, 1969; 41, 1969; 51, 1969; 17, 1970; 27, 1970 and 47, 1970.

The little two-week cycle had even closer coordination with the Dow movements, but, as we know, its oscillations are quite often hidden because of the failure to complete a troughing movement, even though the tendency is present. It follows, thus, that the longer cycles in our chord of cycles are the most regular but that the shorter cycles have the most amplitude. Evidence of this can be seen in the cyclical scales on the charts. For instance, the two-week cycle swings from about 50 to 200—or a 1-to-2 ratio of forces—while the 10-week cycle swings from about 75 to 150. The 25-week cycle, on the other hand, oscillates between 120 and 90, the 78-week cycle between 110 and 95 and the longest cycle between 105 and 97½.

When we look at all of the cycles at once in the charts, we see that the week 41, 1966 troughing of the Dow was almost unanimously the trough of the five cycles, that the third-quarter, 1967 peaking of the Dow came as the result of scattered cyclical peaks, that the week 13, 1968 troughing of the Dow was also a nearly unanimous cyclical troughing. The same sort of performance appears at regular intervals throughout the remainder of the charted periods, with the consensus of cycles and of the Dow in the week 26–28, 1970 span. Because of the tendencies of cycles to synchronize their movements, within their abilities, we can see that it is almost impossible to cut one cycle out of a chord and operate with just one cycle. That is, the cycles work best in combination.



The Art of Forecasting with Market Cycles 5

In 1966, the long cycles which had supported the Dow average, and the market, in its meteoric rise from the 1949 low of 160 to the 1966 high of 1000, apparently topped out, and the market since then has, at best, been a market with a level-to-downward trend.

Certainly, as anyone near the market knows well, the post-1966 market has been a very different market from those prior to 1966 and requires new methods for successful investing. For instance, the policy of buy-and-hold which served investors well for two decades has now been shown to have some very definite flaws, since, in numerous examples, there has been no real way of determining where the bottom of a stock decline is to be found.

The reason that bottoms are difficult to determine in today's markets is that the value bases of previous years have disappeared. Prior to 1929, the base appeared at about DJI 40-60, and cycles carried prices to a high of about 100. After 1929, the base appeared to be at about DJI 100, and cycles carried prices to a high of about 200. Since 1949, however, these bases have become obsolete, and there is little except the troughs of cyclical swings to determine probable stopping areas for a downturn of stock prices.

Since there has now been a succession of troughs since 1949—at about DJI 250 in 1953, 430 in 1957, 550 in 1962, 700 in 1966 and 630 in 1970—we can see that there is a wide variety of possible value bases to choose from.

One of the good things about cycles is that, instead of having to measure a downswing only by the level of the DJI at which a troughing movement stops, the measuring can also be done by means of time intervals because the troughs of cycles come at reasonably regular times. Since these



intervals can be established in advance, subject to fine tuning on a short-term basis, cycles make the finding of definitive value bases unnecessary, since, when a cycle is troughing, we know that the troughing will be followed in due course with a peak, and that, in turn, with another trough.

Now, as we said, the 1949–1966 swing was supported by the long cycles, and the markets of recent years have been, at best, markets with a flat trend. This increases the efficiency of the cycle mechanism, since, with a flat trend, a cycle is free to travel up and down unaided and uninhibited by trendular values. It appears, then, that in future markets, cycles will take on added importance as market tools.

I—The Rudiments of Cycle Forecasting

There are three basic skills which will be required for successful investing in future cyclical markets—all of which are the antithesis of what the average investor has done in the past: lean on the judgment of others. Cyclical markets move fast, and a mistake in a cyclical market is generally incorrigible, except at great cost, since there are only a few second chances to move. The skills which will be needed are:

- 1—The skill of making prompt and independent judgments.
- 2—The mastering of the technique of cycle forecasting.
- 3—The ability to recognize seeds of cyclical change before they sprout.

The first requirement is two-headed: (1) the ability to make decisions when the situation requires instead of delaying or drifting with false hopes and (2) the ability to act on our own decisions at the proper time. These abilities require knowledge of the market and market cycles, since prompt and accurate decisions, instead of indecisions, will largely make the difference between success and failure.

The second requirement—and the first comes more easily if the second is well done—is the learning of the technique of cycle forecasting, or the development of the ability to judge probable future events from the pieces of market action which we can see or deduce from today's events. That is, we must be able to judge from minor events the outcome of major events since all major movements start small.

The third requirement also rests on two premises: (1) change is inevitable in a cyclical market and (2) we can only act once, profitably. Once we have acted, we are completely dependent for future results on the decisions of others over whom we have no control. We can only make money on the long side if others push the price of a stock higher and we sell at the appropriate time. Cycles let us judge the probable mood of other investors.

It would be wonderfully easy to forecast if all the consequences of the forecast rested simply on the developments of the three skills, but forecasting the market remains an art, because it involves two elements—one factual but invisible and the other visible but psychological. The factual element is cycles, which appear as waves of price movement and, since they are the result of a system of force, lend themselves to predictability. The second is volume, which is the prime mover of price but derives, not mechanically but psychologically, from the workings of the human mind.



Now, since we know that cycles cause price movements in the market and that volume determines the extent of the movements, it is possible to forecast within reasonable limits the results we may expect from combinations of the constant variable, cycles, and the independent variable, volume, when we learn the technique of forecasting with cycles. However, since we must base our course of action on probabilities, the possibility of error in our decision is always present, and we must be prepared to reverse our course promptly if expectations fail to fulfill.

Cycle forecasting's seven basic assumptions

When we are dealing with probabilities, instead of certainties, we must make certain assumptions and use them to guide us to a decision. The basic assumptions are:

1—*Forecasting implies that a change in the present situation lies in the future.* That is, since we know about cycles, we know that present conditions must change, that the blooming of a flower is evidence of its maturity and a forecast of its subsequent decline, that nature always corrects an imbalance of force and that cycles result from the correction of rhythmic imbalances as they occur.

2—*The alternation in dominance of the opposing forces is the result of limiting factors which prevent the complete dominance of one force by its opposite number.* If we conceive of cycles as flowing in time and of time as the flow of a river, we must also conceive of time as flowing between the banks of a river and of events which may occur in the future as also taking place within these confines, even though, at times, a flood may cause a temporary rupture of the limits. That is, the alternation of the forces of change must occur within limits, since only the unpredictable lies beyond the limits of cyclical swing.

3—*Tomorrow's visible event is the result of a change or movement today of unseen or unheeded forces.* That is, events as we see them result from underlying forces and are seldom spontaneous. The resultant effect is often exaggerated for two reasons: (1) The human mind has a tendency to extrapolate present conditions in a straight line so that warnings often go unheeded. A good climate looks rosier and a bad climate looks blacker as we look into the future. (2) Because of these erroneous extrapolations, the actual event usually comes as a surprise and causes us to make our moves too late to be profitable.

4—*The images of previous events, which we can see gathering form in the incipient stages of a new cycle, allow us to envision the future.* That is, when we see a seed begin to sprout, we can forecast the shape of the mature plant by identifying the seed or the seedling. When we see a cycle nearing an asymptotic limit of its swing, we can forecast the coming price movement by identifying the cycle and, from experience, its ability to alter the course of events.

5—*Foresight into the future derives from the linked relationship of values moving through time.* Just as a seedling grows into a mature plant and reseeds its strain, cycle values also have a linked relationship—not only to the adjacent predecessor and successor numbers within the cycle, but also to adjacent previous and following cycles. The relationships within a cycle determine the matured version of the cycle, just as environ-



ment influences development. The relationships to predecessor and successor cycles determine the form of the matured cycle, just as inheritance influences development.

6—*Cycles adjust quickly to change.* Prices rise or fall speedily in response to movement of underlying cyclical forces, and investors who fail to keep step often wind up frozen into the cyclical field forcebands of support and resistance, awaiting a second chance.

7—*The force of a short cycle can alter both the amplitude and frequency of a long cycle.* A series of high or low input values into a moving total can override or completely negate the expected response of a long cycle, especially if the thrust is accompanied by exceptional and consistent high volume. The swing of short cycles has great value in decision making, especially if the long cycles are nearing a peak or trough or are in a weakening condition so that they can no longer cushion the short cycle swings.

Price cycles have two axes, and, hence, follow a parabolic path

Individual price cycles have a characteristic which intensifies the beginning of an upward movement and the conclusion of a downward movement. That is, although cycles are circular in nature, they tend to adopt parabolic shapes since cycles really represent the present against a background of the past.

In Fig. 1.11, which shows monthly high and low prices for the Dow average from 1949 through 1966, we see that the shape of the four cycles which are illustrated, are basically that of a cutoff parabola with an uptrend. The fast buildup of values at the beginning of each of the cycles and the fast decline of values at the end of each of the cycles, together with a rounding of the center portion, results in a shape like the small end of an egg. If no trend had been present in the market during this period, it is likely that the cycle tracks would have shown a better parabolic shape, as we can see they did in Fig. 1.8, when there was virtually no trend in the market.

Those of us who remember our geometry, recall that the basic difference between a parabola and a circle is that, whereas the circle has one axis, the parabola has two. In cycles, there are two axes—the past and the present—and, in addition, two relatively fixed radii, one from each of the two axes. It is the relationship between these two radii which causes the cycle to take on a parabolic shape. For instance, in Fig. 5.1 we have drawn a figure in which the length of the radius from each of the axes is equal to the distance between the axes. As we can see, the cyclical path (determined by radius 2) follows an upward circular pattern, from the left of the illustration, until it nears the top of the parabola, when the restraining influence of radius 1 begins to show. At the peak both radii are influencing the path, and, from just past the center of the figure, radius 1 takes over from radius 2 and becomes the determining element, and the path of the cycle again becomes circular in shape on its way down the base.

In Fig. 5.2, we indicate the result obtained when the left axis is moved at regular intervals toward the right axis. Since the central axis (5-1') dominates the beginning of the cycle, it is not until each parabola is nearly halfway through its travel that the left radius (1) begins to take effect, so that each version of the path becomes slightly higher than the previous one, because, although the radius length is unchanged, the



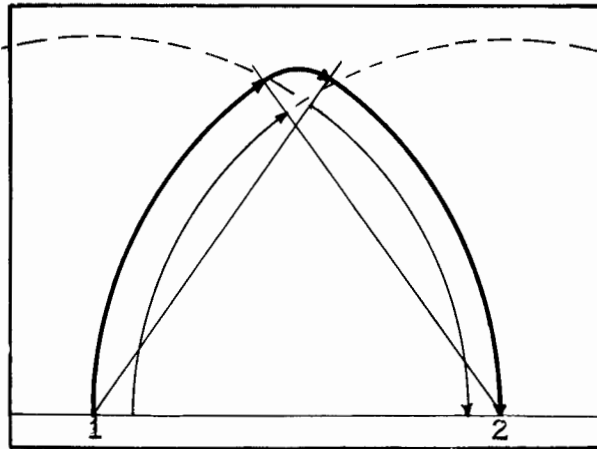

Fig. 5.1—The parabolic shape of market price cycles.

length of reach between the two radii is longer. Finally, both radii emanate from a single axis (5-1'), and the figure becomes circular in shape.

In the figure, we can begin to see the possibility of cyclical forecast. When axis 1 is moved to axis 2, the resulting parabola ends at axis 2', from axis 3 the parabola travels to axis 3', etc. The movement through time thus affects the shape and also the course of the cyclical parabola. That is, the dispersion of the initial force results from one fixed axis in time (5-1') and from one moving axis (1). Axis 1 is the past. Axis 5-1' is the present.

The time progression of the trailing axis causes a Fibonacci grid to form

In Fig. 5.3, we illustrate what happens when all of the movement along the time axis in Fig. 5.2 is drawn into the figure. That is, the circular shape of the cycle results from the centered axis, and the downward arcs on the right of center result from the movement of the trailing axis (1). When axis 1 has moved to the right of center, however, the pattern reverses and the arcs to the left of center are now filled into the pattern. That is, when both axes have reached the center of the cycle, the central axis (5-1') reverses its role in building the cycle.

In the beginning, the central axis was the dominant axis, as indicated by the converged "stalk" of cyclical influences shown by the heavy black line. As the trailing axis moves toward the center, however, the individual influences break away from the stalk and begin to exhibit their individual differences. When the trailing axis has passed the central axis, the central axis reverses its role and becomes the dominant axis for the end of the cycle, gathering individual influences back into the stalk of downward influence. At the beginning, then, the individual influences spread out to cover the future, just as water from a garden hose spreads out over an area when the water nears the center of its arc. At the ending of a cycle, the spreading is reversed and the individual influences again converge to form the downward stalk.

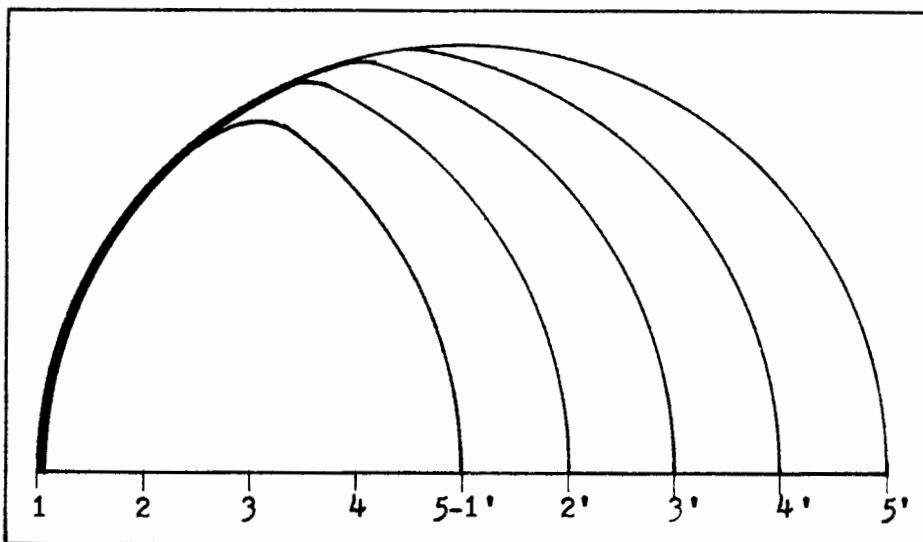

Fig. 5.2—The effect of the movement of a trailing cyclical axis moving through time.

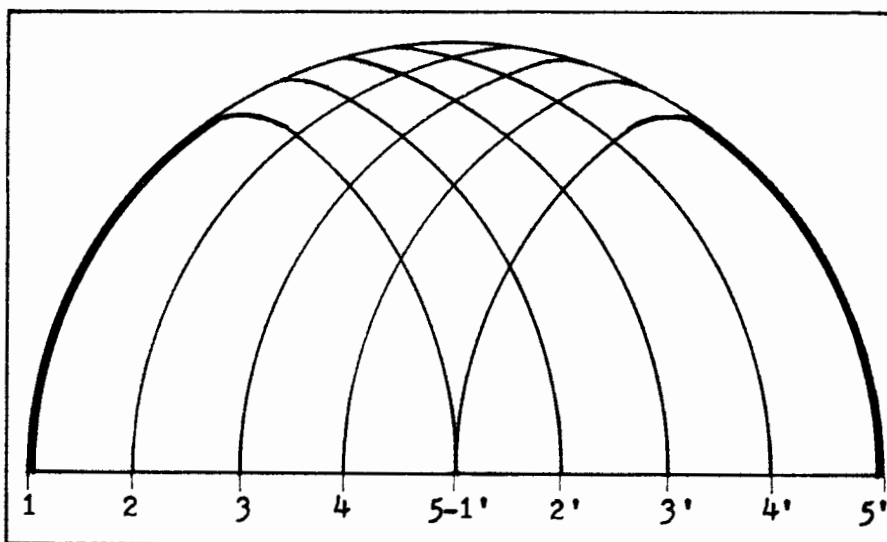

Fig. 5.3—The Fibonacci grid forms when the trailing axis moves through a cycle.

Now, with a little imagination, we can see that the small grid which forms because of the moving axis bears a resemblance to the skin of a pineapple, which is also criss-crossed with a grid of this general shape. Since, as we have seen, the pineapple is related to the Fibonacci number relationship, it is not hard to see that cycles are also controlled by the relationship of the radius of thrust and the radius of growth, since similar grids of influence are formed by the movement along the time axis. In the illustration,



the stalk of upward influence is the thrust of a cycle. The grid represents the breakdown of the upward force. The downward stalk is the recoil of a cycle.

Control of a cycle really stems from the alternation of the role of the central axis of a cycle.

Each mature cycle is a closed system of influence

In Fig. 5.4, we see what happens when the movement of cycles along the time axis, from left to right, is continued beyond the span of one cycle (axis 0-2), and we also get a further hint of the predictability of cycles because of the inherently closed system of influence which determines the resultant cycle.

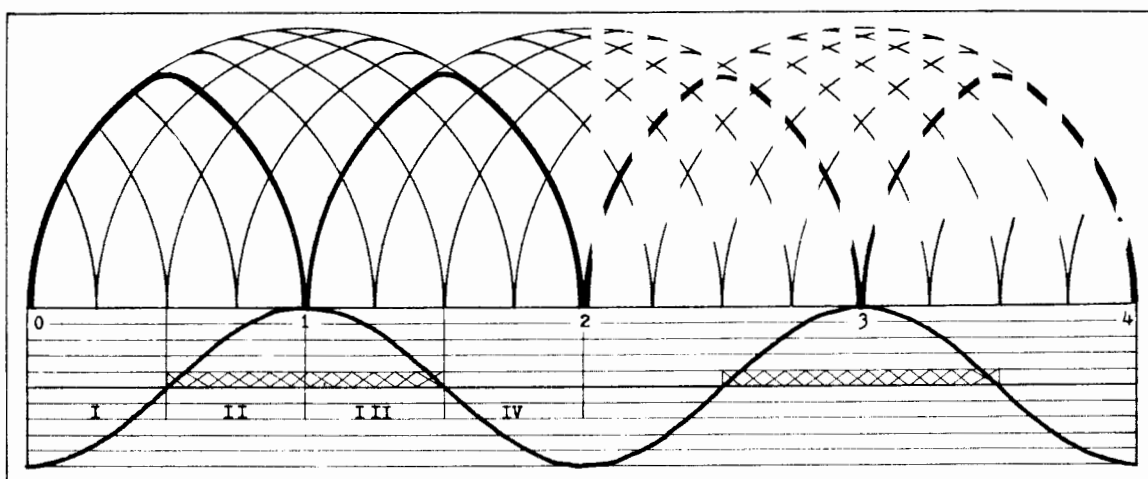

Fig. 5.4—The predictive qualities of the cyclical parabolic shapes when they are extruded into the future.

In the figure, axis 2 (the present) is the end of the first cycle and, also, is now the point of origin of the second cycle, which will lie between axes 2 and 4 and is represented by the dashed lines. In between is axis 3, or the center of the cycle-to-be, which point is (1) the furthest we can see into the future from axis 2 and (2) doubly important as the controlling influence for both the beginning and the ending of the new cycle we perceive. At axis 2 (today), then, we have experience, or the value of the cyclical numbers which originated between axes 1 and 2, and, also, because we can extrude these influences forward in time to as far ahead as axis 3, we have probability.

Looking first at the area of influence which lies between axes 0 and 1, we can see that the upward arcs which converge at axis 2 arose from their meeting with the downward arcs of the previous cycle. That is, they had their beginning at the time of ending of past influences. By the time the cycle had moved to axis 1, however, the control of the influences of the previous cycle had ended. A new cycle, then, is mature when it approaches its central axis, since, by this time, the influence of the previous generation has ended.

In the area of influence between axes 1 and 2, the downward arcs of influence,

which now are matched against the arising new values, had their origin at the beginning of the present cycle. The Fibonacci grid which forms now represents the struggle between the adult cyclical influences and those which came to bear in its youth, since the previous cycle's influences have been expended, so that the cycle at this time is a closed system of influence with the arising forces matched against those which arose in the beginning.

At axis 2 in the illustration, we have a reversal point between the old cycle and the beginning of a new cycle. Since the old cycle influence is now solely downward and the new cycle influence is now solely upward, we can see that, as the new cycle progresses, axis 2 will always be a reversal point of cyclical influence.

Why price cycles spear down at cyclical troughs

Before we go further, we need to explain this point, since it is at axis 2 that the difference between price cycles and the genuine cycles in the market is most apparent. In Fig. 5.4, we can see that the troughing of the price cycle, which is depicted in the upper portion of the chart, coincides with the troughing of the undulating curve in the lower portion of the chart. We have drawn into the chart, then, pictures of the price cycles, which are parabolic, and the genuine cycles in the market, which undulate.

The real cycles, since they are invisible, except statistically, are uninhibited in their swings. As a result they move in regular undulating sine curve patterns, as shown in the chart. The heavy center line, which divides the lower scale into two halves, is the point of balance of the true cycles at zero. The upward swing of the cycle values are counted as plus numbers, while those in the lower part of the swing are minus numbers, or negatives. The true market cycles, then, swing upward from minus one to zero and then to plus one before the reversal occurs.

The price cycles, however, since they are tied to definitive numbers in the market, cannot follow this undulating path. That is, in the market, there are no zeros, even in a bankruptcy, and of course no negative values. The numbers in our moving totals which track the price cycles, then, always have some value and thus can only swing upward from low numbers to high numbers. The result is the price cycles can only spear down at cyclical troughs.

That is, when an erosion of stock prices sets in, as the real cycles pull down, prices will continue their downward course until the cyclical influence of the real cycles is exhausted. By this time, however, prices have eroded sufficiently so that they are in an "oversold" or bargain area and, hence, attract buyers. The result of the sudden buying that results from an "oversold condition" is that the price cycles rebound speedily from their troughs and start on an upward course, since the movement of price from the troughs attracts additional buyers so that the movement continues.

At the top of a cycle, the price cycles and the genuine cycles are in a different relationship. At a cyclical peak, prices have risen sharply and are less attractive to would-be buyers than they were earlier. The result is that buyers, instead of rushing in to buy, are gradually diminishing in number as the peak rolls over the top, but there are still sufficient buyers to cause prices to remain in a high area. Price cycles, then, roll over a cyclical peak and, often, continue high after the peak because of the optimism



which is always present, in direct contrast to a cyclical trough. As a result, price troughs are easy to spot but price peaks are difficult to establish.

At this point, we need to fill in a previous statement about the tendency of the human mind to extrapolate or project in a straight line. At a cyclical trough, the market is never overwhelmed by buyers because of the tendency to extrapolate the downturn of the cycle to an infinite bottom somewhere in the future. At a cyclical peak, the market is never overwhelmed by sellers since the extrapolations now are pointing to an infinite peak somewhere in the future. Since it takes time to change our minds about something we believe in, the bulk of the selling comes in the final stage of the downturn of price and the bulk of the buying comes in the final stage of the upturn of price.

The image of a new cycle derives from the peak of the old one

Again, assuming that we are at axis 2 in Fig. 5.4, with half of the future in the form of extruded values stretching ahead of us to axis 3, we know that, since prices are troughing downward, the genuine cyclical forces are also at or approaching a nadir. We also know that the real force nadir is a gentle one and not the trough which marks price cycles, so, while we know a reversal is imminent, we cannot know exactly when the turn will come. We do know, however, since the future depends on the matching of new values with those from half a cycle back, that half of the key to the turning is represented by our extruded values. The other half of the key, however, is a little more complex. That is, there are factors which may modify our estimate of future input values. The first of these is the harmony-disharmony phases of cycles.

The theoretical cycle which we have illustrated in this chapter is not only a single cycle but is also a chord of cycles, all of different lengths, which includes long cycles, short cycles and intermediate cycles, each one of which has its own characteristics. A short cycle, like all cycles, has a proclivity toward regularity and will make a very determined effort to trough at a regular time interval from a previous trough. A long cycle, having the same determination, will do everything it can to prevent the troughing. This sets the long cycles and the short cycles into opposition at certain periods in their development.

The periods when the long cycles and the short cycles are moving up (or down) together are known as periods of harmony. The periods when the long cycles are moving up and the short cycles are moving down are known as periods of disharmony. Depending on the lengths of the cycles involved, there are, then, alternating periods of harmony and disharmony. As a result, the long cycle path will generally show a period of fast initial growth, a level or downward period when the short cycles are in disharmony and, finally, a period of harmony when both short and long cycles are moving together again.

Now let us see what could have happened in the first cycle in the illustration after the zenith of the first-half parabola was reached. This area between the two parabola peaks is the critical area in the life of a new cycle since we are now entering the disharmonic phase of the cycle, which breaks down into two halves and is indicated by the



criss-crossed lines in the lower part of the figure. In the first half of this period, if a long cycle was dominant, the price cycle would have followed the cyclical circumference upward to the cyclical zenith, or the point directly above axis 1. If long cycle dominance continued, the price cycle would have crested above axis 1 and would then have started down toward the trough at axis 2.

If the short cycles were dominant in the first half of the disharmony phase, however, the price cycle would have pulled down along the circumference of the first parabola and thus would have made a trough instead of a peak in the area of axis 1. From this trough, the movement would have been upward, since the short cycles, having completed their troughing, would be in an upward phase in the second half of the disharmony phase—or the beginning of the last half—of the cycle. We can see, then, that there are two possibilities during the disharmonic phase of a cycle. If the long cycle is strong, the price cycle will peak about as expected. If the short cycles are strong, the price cycle will trough before reaching a peak.

At axis 2, then, the extruded values which originated at axis 1 will reflect the dominance of either the long or the short cycles. If the short cycles are dominant, the values of the old influences will be small and will assure that the new cycle will get off to a good start, providing the new values are stronger, as they should be, than the old troughing values. The combination of old values and new values, then, gives us an image of future events from which we can project our expectations for the new cycle.

In this section, we have learned something of the theoretical operation of cycles and that cycles are really the sum of the varying rates of input and outgo at any point in time, just as is a moving total. For instance, in Fig. 5.4, we saw that the input of values which caused the upward movement of a cycle were also the values which, when they were subtracted, would contribute to the decline of a cycle.

Now the thing that makes cycles work—and also makes them predictable—is that they come in two fairly finite dimensions. The amplitude or vertical distance a cycle will travel is a function of the input, or how many values are added into the cyclical sum, and the length or timespan of a cycle is the function of the input minus the outgo. At the beginning of a cycle, input exceeds outgo, and, at the ending of a cycle, outgo exceeds input. Because these surges of thrust and recoil have finite lengths or radii, the timespan of a cycle is also quite regular. Regularity, of course, implies predictability.

II—The Technique of Cycle Forecasting

The two dimensions of cycles can and do vary, so that we cannot always be correct in identifying the end of a cyclical upswing as half the timespan of the cycle—and neither can we always be correct in identifying the end of an upswing by the vertical distance a cycle has travelled. Both dimensions are variables, with amplitude (thrust) largely being the result of volume increase, and length (recoil after the thrust) being largely the result of volume decline.

Now it is extremely important to cycle forecasting to have a firm point of beginning. That is, if we project the 4¼-year cycle forward according to normal expectations, we may be many months offbase if we use the wrong point as the beginning of



the cycle. The key to correct forecasting, then, is the placement of the first trough of a cycle. To identify these points correctly, we have three aids:

1—*The average length of a cycle.* If we know that the 4¼-year cycle troughed in July 1970, we can project that the next trough of the cycle should occur in September–October 1974, and, as we have seen from past performances, we will most likely be fairly correct just on this assumption.

2—*The amplitude of a cycle.* If we know that the 4¼-year cycle normally will peak out at about 105%—or 5% above its balance point—and will trough at about 95%, we can start looking for peaks and troughs when the cycle reaches these asymptotes.

3—*The phenomenon of cyclical synchronization.* At certain times all cycles in a chord, regardless of their length and position in a cyclical swing, will trough simultaneously, or nearly so.

In a clock shop, if all clocks are started simultaneously, they will chime the hours together. As time passes, however, their synchronization will get out of phase, and before long some will chime early and some will chime late. The only way to get them back to simultaneous chiming is to move the slow ones ahead and push the fast ones back, so that, at a new beginning, all the clocks will be chiming together. The same thing happens to market cycles. They get out of phase and are occasionally brought back into synchronization.

How to establish the limits of cyclical swing

It is quite often easier to see a big picture from a small chart than from a large one because the detail of a large chart often hides the outlines of the real object of our attention. This is also true of a cyclical picture, as we illustrate in Fig. 5.5, which shows four of the five cycles in our chord of cycles against the background of the 1966–70 movements of the DJI, on a weekly basis. In cycle study, we need to have both daily and weekly charts of the happenings, since the timing of moves in the market needs to be done on a daily basis, but the weekly chart gives us a perspective which is not always present in a daily chart.

It seems appropriate, at this point, to come to the defense of chartists, since it appears that many people assume chartists have something to do with the occult. Basically, a chart is a visual representation of statistics, whether they are stock prices, the quantity of money supply or simply an indication of the growth or decline of a business. There is nothing occult about the ability to read charts either, since chart readers are not soothsayers in the usual sense but students of statistics. That is, market students make charts because it is considerably easier to see a market movement from a chart than from a page of numbers. It is, of course, more difficult than taking someone else's word for a stock's performance—if you prefer a modicum of the occult.

It is also unfortunate that a person may gain a reputation as a chart reader without knowing the first thing about reading charts. The market, as we know, is a place of change—a place where there are always two sides to every transaction and where only time can prove which side is the correct one—so that, not from what they see in a chart but, from the psychological viewpoint with which they view a chart, it is possible for

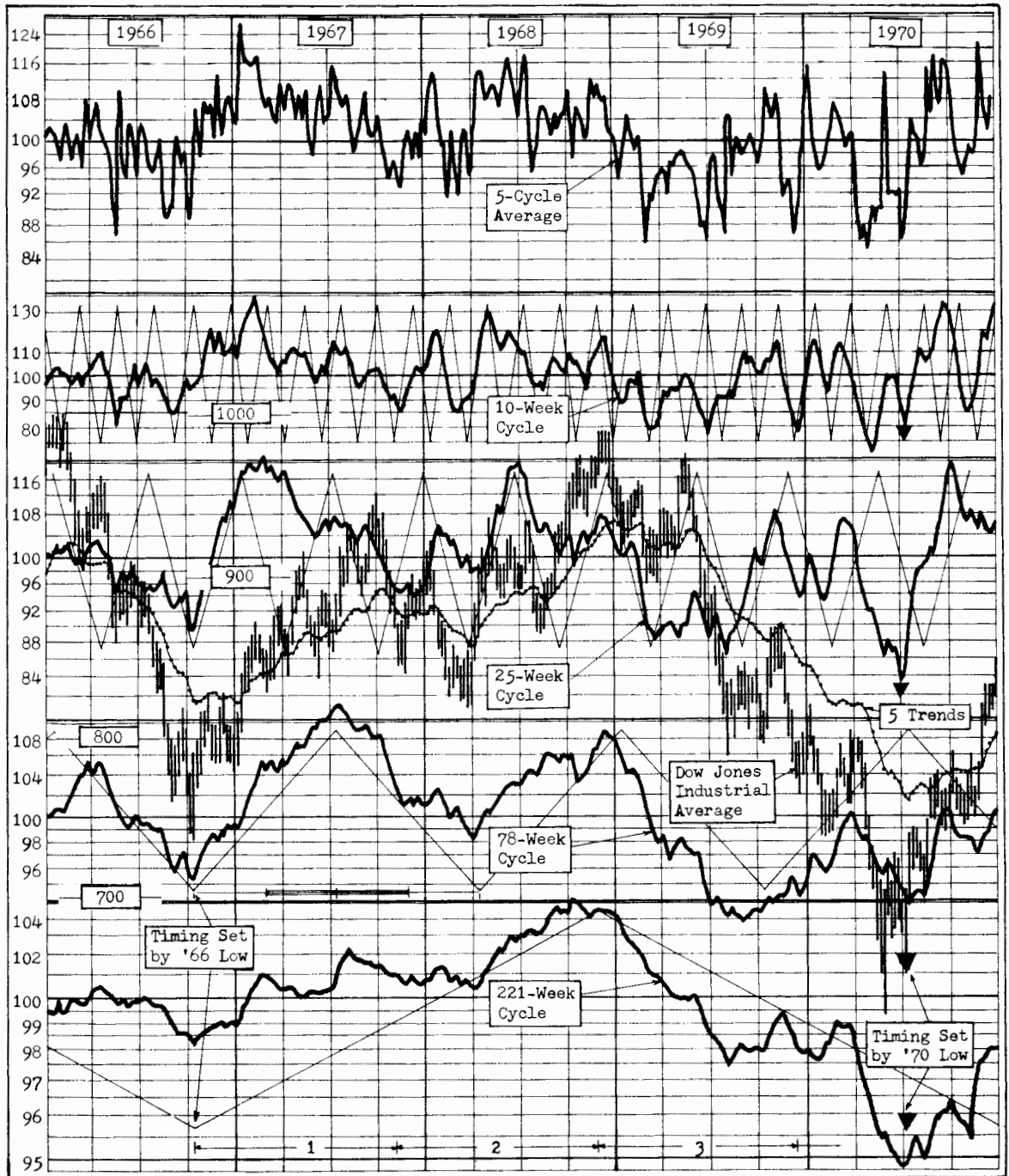

Fig. 5.5—Weekly chart of the 221-week cycle and other cycles in the chord of cycles, 1966–70.

two persons to make opposite predictions from the same chart. One is viewing the chart with smoked glasses, the other is wearing rose-colored glasses.

In Fig. 5.5, we have a good opportunity to study in a single glance the whole range of the 1966–70 market cycle, and, incidentally, to establish the asymptotic limits of the swing of our chord of cycles during this period.

First of all, we notice that the 221-week cycle advanced from a low of about 98 in 1966 to a high of about 105 in 1968. From the peak, the cycle declined to a low of about 95 at the 1970 cyclical low. Now, if we look at a table of tangent values in a book of natural trigonometric functions, we see that a tangent value of 0.95 occurs in the table at $43^{\circ}32'$ —or one degree and 28 minutes below 45° , where the tangent value is 1.00. A tangent value of 105 occurs at $46^{\circ}24'$ —or one degree and 24 minutes above the 45° balance point. The swings of the cycle, then, were equally on either side of the balance point, so that, in this version of the cycle, the cycle was balanced and the asymptotes were established at 105 and 95 on either side of the balance.

The 78-week cycle reached a high of about 109.5 in the second half of 1967 and a low of a little less than 92 at the 1969 low. Since 109.5 occurs in the tangent table at $47^{\circ}36'$ and 92 occurs at $42^{\circ}37'$ we can see that this cycle also oscillated around 45° , since the high was $2^{\circ}36'$ above 45° and the low was $2^{\circ}23'$ below 45° . The same equal swings are visible in the track of the 25-week cycle and also in the track of the 10-week cycle. Since tangent values are easily translatable into sine values, we can see that the cyclical swings were really following sine curve swings—or regular limited undulations.

In Fig. 5.6, we see the tracks of three of the cycles during a different period—this time the 1953–57 version of the 221-week cycle. Now it is readily apparent that this version was quite different from the 1966–70 version. The market atmosphere in 1953–57 was headily bullish so that the Dow average ran up from a low of about 260 to a high above 500. By way of contrast, the 1966–70 version ran from a 1966 low of about 750 to a high of 1000 to a second low near 650. We are matching, then, a bullish cycle against a balanced cycle—or one with a strong uptrend against one with a slight downtrend. As a result, the 1953–57 cyclical tracks are quite different.

The 221-week cycle started from a low value of about 109 in 1953, reached a high in excess of 112 and declined to a second low at 102. It was unable to return to a negative position below 100 to balance its swings. The 78-week cycle also was unable to decline below 100, except briefly at the 1957 bottom. The 25-week cycle was also pushed well above the balance point for most of its swing.

Now we need to make a little adjustment in our asymptotic ceilings for the cycles. First the 105 ceiling for the 221-week cycle must be raised to a possible 112; second, the 120 ceiling which occurred in the 1966–70 swings of the 25-week cycle remains unchanged, as does the 130 swing ceiling for the 10-week cycle. Since none of the cycles in the 1953–57 version approached the 1966–70 lows, we can assume that the lows also need little adjustment.

What have we learned? First, we see that our TORQUE values for the invisible market cycles swing in regular undulations which resemble sine curves, and, second, we see that each cycle has a different asymptotic limit of swing, with the smallest cycles



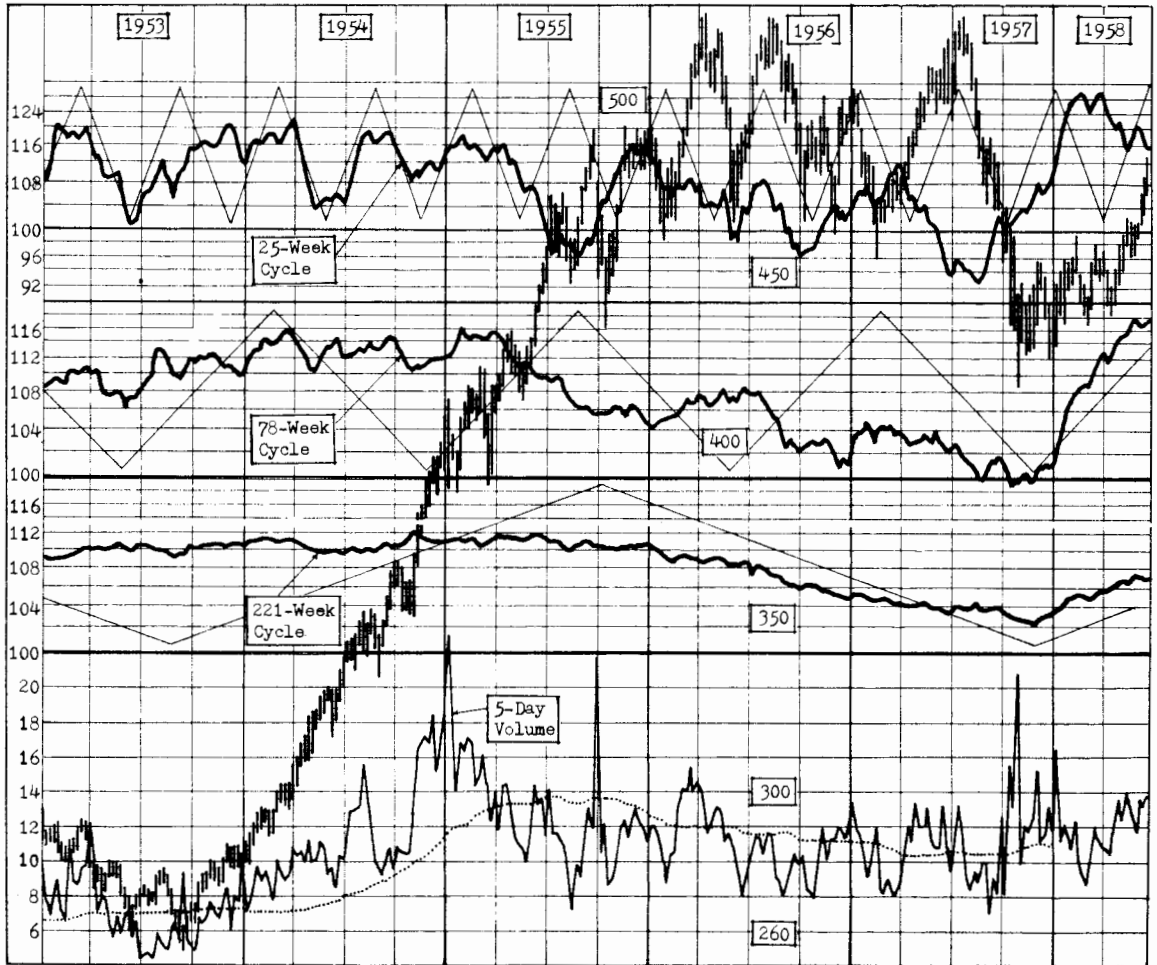

Fig. 5.6—Weekly chart of the 221-week cycle and other cycles in the chord of cycles, 1953–57.

reaching to the highest ceilings as an indication of their volatility, and the largest cycles reaching to lower ceilings as an indication of their stability. Third, we have determined that asymptotes, like trend, are historical in nature, and, fourth, and most important, we note that a cycle is likely to reverse or alternate, when it approaches the limits we have drawn into the charts. This is particularly evident in the track of the 25-week cycle in the 1953–57 chart. When the cycle approached a high of about 120, it was giving a signal that its force was about expended, and when it approached a low of about 95, it was ready to move upward.

When we check these asymptotes against the tangent values of the numbers, we find that during the 1953–57 cycle, the 25-week cycle had an upward bias. That is, the 120 value is more than 5° above 45° but the 95 value is only $1\frac{1}{2}^\circ$ below the

balance point. As we can see, then, an uptrend in the market will be reflected in the failure of the downward swing of a cycle to equalize with the upward swing. Similarly, of course, a downtrend will be reflected in the failure of an upward swing to reach the top asymptote, as we see in the 1969–70 swings of the 25-week cycle in Fig. 5.5. Obviously, then, forecasting remains an art, since there also must be an exercise of judgment in ascribing asymptotic limits of cyclical swing as a cycle develops.

How cycles synchronize their clocks at cyclical troughs

As we have seen, the swing of the 221-week cycle in the 1966–70 period was the first version of this cycle which did not have an uptrend. Since, as we have also seen, an uptrend in the market affects cycles as well as market averages, a cycle without a trend makes an excellent subject for cycle investigation, since the swing of the market at such a time is largely the result of cyclical force. In Fig. 5.5, then, we can study some of the other factors, besides trend and asymptotes, which affect cycles.

The first factor that needs investigation is the regularity of the rhythms of the various cycles within the cyclical chord; second, is the effect of the harmony-disharmony phases on a cycle and also on the probabilities of prediction and, finally, the reasons that longer cycles tend to break into harmonic lengths instead of living out their full swings.

To assist the eye, we have placed on the chart of Fig. 5.5 light lines which mark the “ideal” or mechanical version of each cycle, and, to begin with, we considered that the 1966 troughing of each of the cycles was the correct timing for that cycle. That this timing did not hold for all of the cycles is evident from the variation of the real cycle tracks from the mechanical version in 1970. That is, if we accept the idea that a cycle is limited by its radial asymptotes, we can no longer accept the idea that a cycle will always beat exactly on time, even though on average it will exhibit a regular length. Since some of the cycle swings are longer and some are shorter than normal, the average length of a cycle is only an approximation and not an exact measurement, regardless of the number of decimal places involved.

As we saw earlier, each cycle, when it has been weaned away from the influence of the previous cycle by the passage of time, is a closed system within itself, so that the new values appearing in the second half of the cycle are matched against those which occurred in the first half. That is, as a cycle approaches its midpoint, the influences of the previous cycle rapidly diminish, and, some time before the exact center is reached, the linked relationship between the values of the old cycle and those of the new are greatly diminished or nonexistent.

Since the cycle is now an adult in a literal sense, its “peregrinations” are now its own responsibility. It follows, then, that the exact timing of the new cycle, while within the control of the central radius, will vary as the new cycle develops its new values. Accordingly, as we can see in Fig. 5.5, the timing of each cycle will need to adjust—or the cyclical clocks will need to be synchronized by an affair such as the 1970 cyclical bottom. One measure of the validity of a cyclical bottom, then, is the number of cycles which become synchronized by the troughing of price. For instance,

at the 1966 bottom, the 10-week cycle troughed in the 36th week, but the 25-, 78- and 221-week cycles all troughed in the 41st week of 1966. At the 1970 bottom, all five of the cycles became synchronized.

We can also see from Fig. 5.5 that the 221-week cycle, since it peaked almost exactly on schedule at the end of 1968, was very regular in its swing except for the lopping off of 25 weeks of the downswing by the clock-setting cyclical trough of 1970. The 78-week cycle also showed great regularity during this period, peaking and troughing almost on schedule, except that the 1969 trough came earlier than the mechanical cycle indicated. Also, from this track, the 78-week cycle was not anticipating the movement which chopped off its swing in July 1970. If the 4¼-year cycle had fulfilled its promise to trough in late 1970 or early 1971, the last phase would have been marked by a peak of the 78-week cycle in mid-1970 and the gradual decline to a low at the end of the first quarter of 1971.

The 25-week cycle, as is normal, demonstrated less regularity in its movement than the longer cycles and got almost fully out of phase at the end of 1967. It was brought back into synchrony by the 1968 market low at the end of the first quarter of 1968, but immediately got out of phase again in the descent from the peak. The May 1969 low got the cycle back into time, but it was again upset until it matched the 1970 timing at the July low.

The 10-week cycle also displayed little regularity during this version of the 221-week cycle. This is, however, not abnormal since the 10-week cycle is greatly affected by the force from other cycles, so that its track record for consistency is low. Also, the cycle tends to anticipate cyclical lows of other cycles by troughing a half-cycle previous to the lows of the other cycles and corrects its swings by extending into swings of 20 and sometimes 30 weeks in length.

We can see from the charts, then, that regularity of rhythm increases with the length of a cycle, so that the longer rhythms in our chord are the most regular and the shorter rhythms are the least regular, but the irregularity of the smaller cycle is brought into correct phase by the simultaneous troughing of all cycles at a genuine cyclical low.

How the TORQUE formula overcomes lag in moving advances totals

Earlier, we saw that a moving total acts like a filter, washing out values which are smaller than the “mesh” of the filter and retaining values which are larger; also, we saw that if we use a moving total which is the same length as a cycle, we will wind up measuring not the cycle but any trend the cycle may have. Moving totals allow all frequencies smaller than the total to pass through the filter almost completely, and the filter washes out a frequency of the same length but retains all larger frequencies.

When we measure a cycle with a moving total, then, the results we get are not those of a single cycle but of a combination of all cycle frequencies which are longer than the moving total. The longer the moving total, the fewer frequencies are involved in the total and the smoother it becomes. The smaller a moving total, the more frequencies are combined in the total, and the consequent track of the total becomes “rougher.”



This combination of force of all larger cycles in a small cycle results in the lessened predictability which is a characteristic of small cycles. As we mentioned earlier, in Fig. 5.5, the smaller cycles demonstrated less tendency toward regularity than the larger cycles—but the smaller cycles have a double problem. They must fight for their own recognition, while, at the same time, they must demonstrate the longer elements which are part of their composition.

For instance, in Fig. 5.5, we can see that the 10-week and the 25-week cycles demonstrated both parts of their nature. The 25-week cycle tried to keep time with its own rhythm, and, at the same time, it came fairly close to matching the swings of the 78-week cycle. That is, it troughed just ahead of the 78-week cycle trough in early 1968, it peaked ahead of the 78-week peak in late 1968 and it troughed again with the 78-week cycle in mid-1969. The 10-week cycle did much the same, so that if we look at the track of the 10-week cycle from two viewpoints—that of the cycle itself and that of the longer cycles as the second viewpoint—we can see that the 10-week cycle also demonstrated its own characteristics and also those of the other larger cycles.

At the top of the figure, we have combined the five cycles in our chord into a simple average, giving each cycle its own weight in the average. That is, the smallest cycle having an amplitude which ranges up to 200 on occasion got the full amount of value of its strength while the 221-week cycle, which ranges only up to about 105, also got its proportionate share. From the illustration, we can see that each cycle within our chord really demonstrates all larger cyclical forces. That is, the average shows the movements of the 10-week cycle and all the other cycles as well, and thus demonstrates the swings of the large cycles as an overall movement and also the swings of the small cycles in the oscillations of the total.

This is also illustrated in Fig. 5.7 in which we picture four of the moving totals during the 1970 troughing period. As we can see, the shortest total—the five-week total of the 10-week cycle—is the “roughest,” since it deals not only with the long cycles but also with cycles which approximate five weeks or longer in length.

In the illustration, beside the long totals of advances are the input and outgo values in a five-day moving total, just as in Figs. 4.6 and 4.7. Now we can see the effect which input, which is the same for each total, has on each total when it is matched simultaneously against the outgo values (the light lines) of the longer totals.

Our cyclical measurements are largely the result of the swing of the number of stocks advancing, as registered in each of the moving totals, and we can see that as the totals get longer, there is a tendency for them to lag a cyclical trough. That is, the shortest total troughed at the bottom of the market, the second shortest troughed at the July low and the 39-week total troughed six weeks later. The low in the two-year total, however, did not come until the middle of the fourth quarter. We see, then, that even though our unit values in the totals are limited in range by the universe within which they operate, there is still a tendency for the total to lag an actual bottom.

Now if we have lag, how do we know when we hit a cyclical bottom? That is, if our moving totals are lagging, how do we know that the 4¼-year cycle troughed in July 1970 instead of in November as the moving total shows?

In the upper portion of the figure, we show the tracks of our cyclical TORQUE



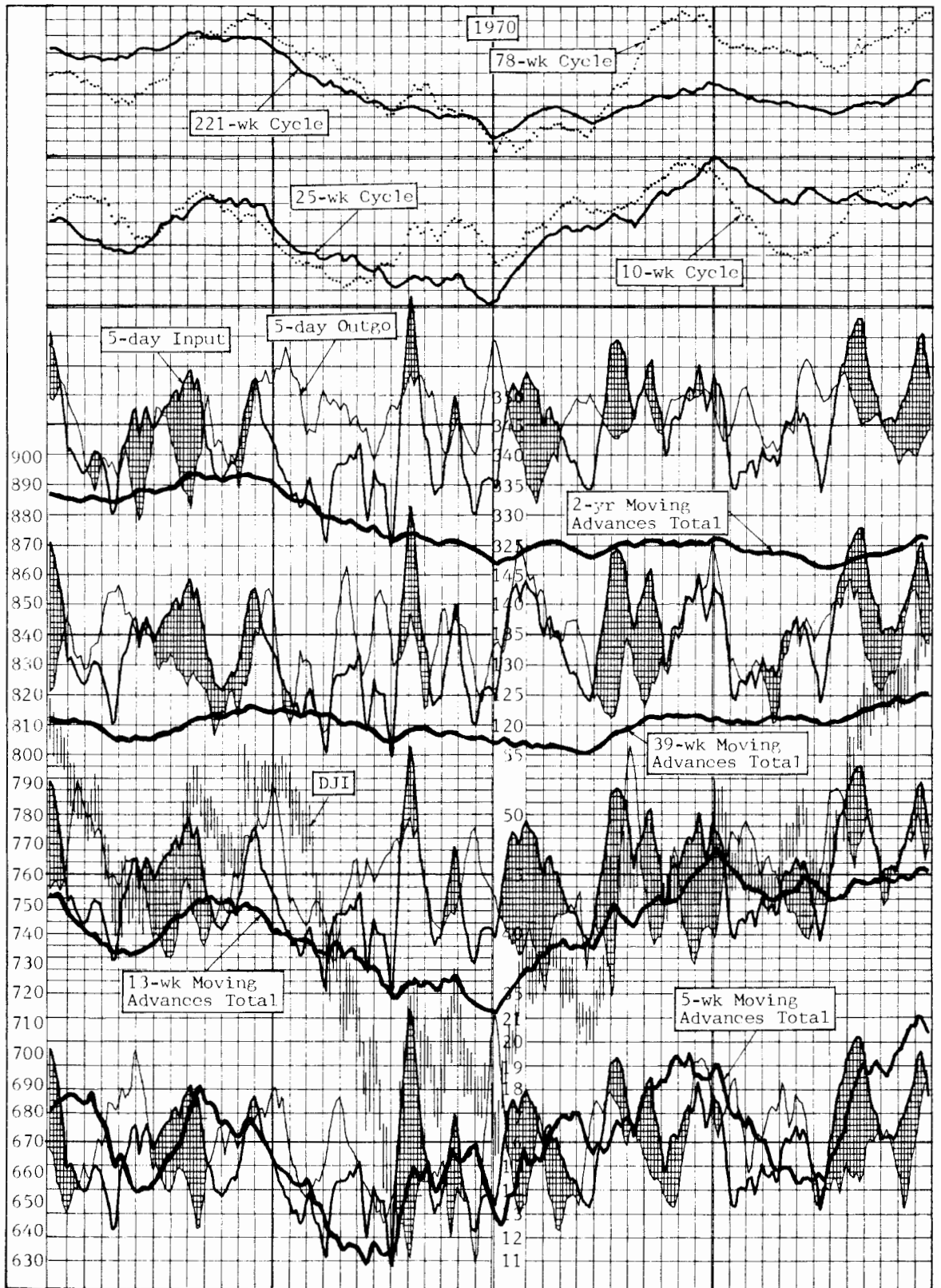

Fig. 5.7—The basis of market price cycles—input vs. outgo—and the resultant TORQUE values in the trough and rebound of the cycles, 1970.

values, which are obtained by dividing the A-D ratio by the buy-sell ratio of volume, and we see that from this division we obtain different results. That is, all four of the cycles show definite troughs at the center of the figure. The reason, of course, is that by dividing price by volume, we take up much of the lag present in the moving averages totals. We saw how this worked in Fig. 4.10, so we know that the difference in results arises basically because price swings more widely than volume. Volume expands in an upsurge of price and declines in a downward swing of price but never swings as widely as price.

Forecasting the future by extrusion of moving total values

Now there is more to Fig. 5.7 than is immediately visible since the figure contains the elements which make prediction of cycles possible. Through the center of each group of input-outgo values, we see that a heavy horizontal line has been drawn: at 345 in the long total and at 135, 45 and 16 in the other totals. This line represents the balance point of values of the five-day totals of the little two-week cycle which we use as the input cycle. That is, at this time period, values in a five-day moving total of advances centered around 3300, swinging as high as 5300 after the market bottom and as low as 1300 during the market's slide to the bottom. In other words, when values in the total built above 3300, we knew that sooner or later the values would decline and move below that value.

In the illustration, the outgo values of the five-day total are illustrated by the light lines and the input figures are illustrated by heavy lines. For the moment, however, let us imagine that the heavy lines and the cross-hatching are not present in the big two-year total but that only the light lines are there. In the first quarter of the year, we can see that the light line of outgo was mostly below the 3300 value line of the chart and that only short spear points were above the line. Similarly, we can see that, in the second quarter, the light outgo value line was mostly above the centerpoint.

Now these values, we know, are takeaway values or will become negative values when the moving total reaches each one. We have, then, extruded the input cycle ahead of the moving total by its own length. That is, in the case of the 39-week total, the end of our extrusion, or today's input value, is now extruded 39 weeks ahead of the total. Opposite tomorrow's input value will be the input (as outgo) from 39 weeks previous. The end-formed moving total, then, will move up or down by the net difference between the new input figure and the outgo figure from 39 weeks previous. This we can see, in the case of the two-year total, in the center of the first quarter of 1970. The hatched areas indicate that the input figures for the five weeks were greater than the outgo figures, and that, as a result, the moving total increased from a low of about 332 to a high of about 337 during the period.

In the second quarter, in the two-year total, we see that the opposite occurred. The outgo values for the most part were above the center line, or were high values, while the input figures were small, as indicated by the heavy line. The result was a debit between the two matching figures, and the moving total came down during almost all of that quarter, since there were only two weeks in which the input exceeded the outgo.

With this arrangement of extruding upcoming outgo values ahead of the moving



total, prediction of the movement of the total consists largely of estimating what the input is likely to be, since, with end-formed totals, response of the total is in the immediate present and easily visible since the total is not lagging the new input.

Now let us see how the market, as measured by the DJI, corresponded to the movement of this moving total. (The figure gets a little “bloody” from all the information which overlies the Dow high-low figures. Sorry about that!) With a little difficulty, then, we can see that from the beginning of the upward movement of the long total in the first quarter, the Dow rose to a high and lingered at the high a little longer than this total.

In the second quarter, when the total was declining, the Dow declined, and, in the later quarters, there was also good correlation between the Dow and the total, despite the obvious lag in the total. That is, even though the total troughed in November, instead of July, it made no difference to the cyclical values and little overall difference to our predictions from the extruded outgo figures. It is interesting to note that later the National Bureau of Economic Research concluded that the end of the business decline came in November 1970.

The rest of the chart you can figure out easily on your own, but we do want to make a point concerning the 39-week total. As we can see from the extruded outgo line in the third quarter, it looked likely that this total would decline in the early part of the quarter. The total dipped only slightly, however, since, as we can see, the input very nearly matched the high outgo values in the first few weeks. In the cycle chart, at the top, we can see this hesitancy (of the moving total) is visible in the 78-week cycle track, which went mostly sideways during the period of the high outgo figures.

By extrusion, we match the heartbeats of today's and yesterday's markets

Now we would like to emphasize that this method of predicting the performance of a moving total which mostly determines the performance of the resultant cycle, can be used with cycles of any length. It works for the 4¼-year cycle, as we have seen, and it even works for the little two-week cycle because: (1) we know that when a cycle reaches or approaches an asymptote, it will reverse its direction; (2) we know that lag does not unduly affect our end-formed A-D moving totals because of the oscillation of the raw data within a universe and (3) we know that, even when lag is apparent, the TORQUE relationship of price and volume will correct most of the lag because volume (1) increases as prices rise and (2) decreases as prices fall.

Why does so simple a method as extruding values within a moving total ahead of the total work so well for predictive purposes? The reason is found, we believe, in the strong cyclicity of the smaller cycles in the market. In Figs. 5.5 and 5.7, we pointed out the “roughness” of the short totals and how much short cycle activity was visible in these totals, and also in the track of the Dow average.

When we extrude the cyclical values from within a total ahead of the total, we are, in reality, extruding the short cycles, which our short total picks up ahead of the total. Since there is this strong cyclicity in the short cycles and since the cycles would be regular if they were immune to the effects of investor psychology and the influence



of adjacent cycles, we can see that, if our timing is correct, we are matching a single short cycle against a previous single short cycle, both of which demonstrate not only their own cyclicity but also that of all the larger cycles at the same time.

Now long cycles build from the oscillations of small cycles. As we can see in Fig. 5.7, the movement of the long totals depends on the match between previous short cycles and the present cycles. If the match was perfect, there would be no buildup whatsoever of the long cycles, but, because of the differing versions of the short cycles, there is a difference of values which is picked up and retained within the long totals which are the basis of the cycles.

We are, in other words, matching basic rhythms—the oscillations of the “heart-beat” rhythms of the short cycles—the present rhythm against the past, and, since there is an underlying similarity of performance, there is a good match most of the time, but the differences between the matches account for the buildup and decline of the long cycles.

In theory, a very small pump could drain an ocean, if it had somewhere to dump the water it drains off. In practice, the regular oscillating beat of the small cycle rhythms builds not only the small cycles but also the very biggest of cycles. By extruding the basic rhythm of our smallest cycle into the future, then, we are extruding, as probabilities, past performances of the basic rhythm, and the validity of the probability is determined by the match of new values against those we can see as negative values in the extrusion.

Now why, also, do we need to pay so much attention to the small cycles? Why don't we just adhere to the long swings of the long cycles and forget, as some analysts suggest, the “minor” movements? The reason is that, fundamentally, everything starts small. As we can see in Fig. 5.7, the differences between input and outgo in many cases is extremely small, but, since the moving total affected will retain these differences and since it is from these differences that long cycles build, it is a necessary part of cycle study to watch all the moves of all the cycles we can identify. For successful prediction, we must be able to judge from tiny differences, in advance, the major differences which will arise later, as the residue of cyclical strength is retained-in or washed-out of the moving total affected.

The swings of the little cycle, then, are as essential to the well-being of the long cycles as the heart-beat swings of the small heart muscles are to the well-being of a 300-pound man. The huge muscles of a big man are dependent for their functioning on the small muscles of the heart. So it is with cycles.

III—The Effect of Volume on Cycle Forecasting

When you work with price cycles in the market, there is one thing for which you must have the highest regard—the inevitability of cycles.

Cycles, as we know, are sometimes vicarious, so that one cycle appears to be acting for another, and sometimes they are lazy or slow in their expected response, but there is one thing which they always are—inevitable. The short cycles trough with



regularity, even though the trough may not appear to be a trough; the long cycles trough with regularity, even though the long cycles are prone to shortening and the middle-sized cycles trough also at regular intervals.

The idea of cycles is hard for some people to accept, since it goes against the grain to believe that we do not control our own destiny. Maybe it's ego or maybe it's lack of attention, but most of us simply refuse to understand that cyclical troughs and peaks are only a prelude to a reversal of the cyclical tide. Part of it comes because of the slowness with which cycles ride over the peaks. The peaks are round, as we saw earlier, and movements—except the spearpoint, high-volume peaks which sometimes occur—are generally slow, so that, like the going out of the tide, we aren't really aware of what is happening until we find ourselves stranded on the beach of false hopes.

One of the key factors in assessing the outlook for cycles is volume. That is, volume builds and prices rise, and volume declines and prices fall—since the two are inextricably tied together. Part of the effect of volume springs from the fundamental side of market analysis, or the economic outlook, and the outlook for individual stocks. Part of it springs from the technical side, and part of it is seasonal in nature. Let's look.

The influence of economics on market cycles

At the very beginning of the book, we stated that stock prices move in direct response to only two influences—cycles and the economic outlook. Since we have learned about cycles, it is time to take a look at the influence of economics on market cycles and, hence, on market averages.

Economics—or rather the economic outlook—affects the market in four ways:

1—The state of the nation's economy throws a shadow which affects the trend of the market. That is, since it is pretty well established that the market is a leading indicator of the state of the economy, it follows that economic forecasts exert force on the market, so that, if the economic forecast is upward, the market trend, which is also leading, will also be upward until such time as the forecast shows signs of weakness. The state of the economy, thus, points the general direction which the market, as the economic advance party, will travel.

2—The economic outlook affects the market through the force it exerts on the volume mechanism. When people have money, as they do when the money supply and savings rates are increasing, and when the outlook for the economy is upward or inflationary so it appears that more money will also be available, people are inclined toward stock purchases. Volume, thus, is a direct manifestation of the prospect for the economy, and, since volume is the driving force of the market, volume increases result in price increases in the market.

3—Since the market is a leading indicator of the economy, it is necessary to anticipate the economy to make money in the market. The basis for this is that if the economy is trending upward, it is likely that most companies will tend toward higher earnings, and, as a result, stock prices are likely to rise. On the other hand, if the economy looks poor to bad, so do the prospects for most stocks' earnings, and, as a result, prices are likely to decline.

4—Economic anticipations and market cycles come in the same sizes. The significant



cycles in the market are of approximately the same length as the market's anticipations for the economy. Economists have a tendency to make their forecasts by quarters, since facts for many of the economic indicators are gathered each quarter, instead of monthly. Also, company earnings are reported quarterly—a fact which does not escape the market. As a result market cycles tend to be most significant when they are in multiples of quarterly lengths. The 25-week cycle, for instance, almost encompasses two quarters, while the 78-week cycle is six quarters long.

The economic outlook, thus, affects the market primarily by (1) supplying a trend for the market and (2) providing surges of volume as the outlook changes. Market trend arises principally because of its association with earnings. That is, as the fundamentalists hold, there is a relationship between earnings of a company and the price of its stock. That this is a valid assumption can be seen in Fig. 5.8,* which shows the tracks of the DJI from the beginning of 1959 through the first quarter of 1971, and, also, the combined earnings of the 30 Dow stocks on a 12-month basis. The chart is made by establishing a 15-times price to earnings ratio, so that a \$40 earnings total for the 30 stocks (left scale) is at the same chart level as a 600 price for the DJI average (right scale) and a \$60 earnings total is on the DJI 900 level. The ratio, of course, is figured by dividing the DJI price (900) by the earnings figure (\$60).

The fundamental theory would be a good one if the price/earnings ratio would hold still. Unfortunately, however, the ratio changes. In the period from 1959 to 1966, the ratio was well below the Dow price—or the Dow stocks were selling at more than 15 times earnings—and in 1966, 1969 and 1970, the Dow stocks were selling at less than 15 times. The biggest gaps between the two came in the upward bulge of the Dow in 1961, when the average was selling at more than 700 and earnings were at about the \$30 level, or a P/E ratio of better than 23 times, and at the 1970 market low of about 630, on earnings of about \$54, when the Dow was selling at only about 12 times.

Assuming, then, that the Dow average is a good representation of the economy, it is obvious from the correlations between the two curves in the chart that it is earnings which set the trend which the market follows, since earnings are a good indicator of the condition of the economy—except that they are historical by nature and also long-term. Which is why, of course, spot economic news, unless it is of sufficient significance to change trend, has only a temporary effect on prices in the market.

Volume is cyclical, psychological and seasonal

As we have indicated, the economic picture affects cycles through its influence on the flow of volume in the market. Volume is the fuel that drives the cyclical engines, and, if volume were purely cyclical, its rise and fall in quantity and its mixture of buying and selling volume would be relatively easy to diagnose, but sometimes, especially when you are waiting for a volume surge, it is easy to feel that point-and-figure chartists have the best idea—ignore it completely.

* Chart from Three-Trend CYCLI-GRAPHS, published quarterly by Securities Research Company, a division of United Business Service Company, 208 Newbury St., Boston, Mass. 02116.



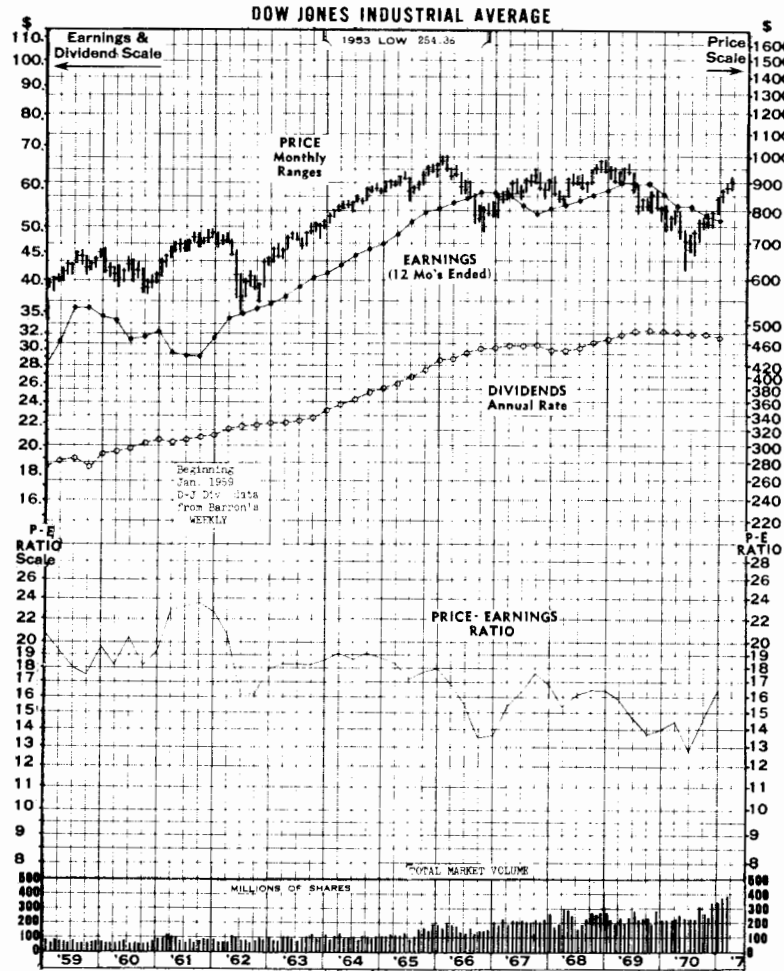

Fig. 5.8—The relationship of earnings and the Dow industrial average—on a 15-times P/E basis.

Volume, however, is so completely entwined in the cyclical system that it cannot be ignored since volume is essential to movement in the market. When volume is high, stocks are moving—upward or downward—and when volume is low, stocks are static with a tendency to drift lower. Price, after all, is not a stable item, and, without buying, prices decline and decline. When volume of buying is small, the supply of stock depresses price and the result is the gradual drift of price patterns.

A study of volume patterns over the years reveals that there are really three principal characteristics to volume: (1) Volume is cyclical in that it generally responds simultaneously to the upward pull of cycles with an increase in quantity, and to the downward push of cycles with a decrease in quantity. (2) Besides the cyclical effect which is present in the volume curves, there is also an economic factor involved. When

business is good, volume increases as more and more people decide to invest. This tendency was evident in Figs. 2.2–2.3, when volume increased as the economic outlook grew better, with an especially marked surge of volume in the late 1920s. In the depression years portrayed in Fig. 2.4, volume, except for an occasional surge, diminished to pre-World War I levels, and in Fig. 2.5 we can see the rise of volume which marked each economic upturn, finally, beginning in 1962, becoming a steady upward movement. (3) To cap everything off, volume is also seasonal, as we saw in Fig. 3.8 with marked tendencies to lows in February and sometimes March, again in July and, generally, in August.

The seasonal pattern in volume figures

The seasonal pattern which is evident in volume figures in the market, on the surface, at least, appears to be a people pattern. For instance, an authoritative statistics book * displays two charts which show such disparate things as newsprint consumption, which has a February low, a March–April–May high, a July low and an upward slope to the October high, and (2) the payment of life insurance death-benefit payments, which has the same February low, a March high and a gradual decline to September, followed by a rise in October.

That volume charts reveal about the same general topography is evident in Fig. 5.9, which illustrates weekly volume totals as a percentage of a five-year average volume figure (the heavy line) and a weekly buying volume expressed as a ratio to selling volume (the light line). When the lines are above 100, the heavy line indicates more than average volume and the light line indicates more than half of total volume was in the buying category. In the chart are two sets of lines, one for the 1953–57 cycle and one for the 1966–70 cycle. Since these cycles were extremely different, as we have seen, a general agreement of the two curves is additional proof of the seasonal pattern.

Before we go further, readers are warned that these are *average* patterns. It would be unwise to accept the patterns as weekly predictions of future patterns, since, in making the average, there are some very unaverage performances combined into the total. The principal value of the chart is to show that there is a tendency for volume to rise and fall in quantity with the changing seasons. For instance, in the first cycle, there was more than average weekly volume in the market in the first quarter, even though the curve hits a low in the first week of February. In the second cycle, the low comes in the final week of March, and, during almost the entire quarter, volume was less than average. In both patterns, volume held high through April and then gradually declined until July. A spurt of volume in early July cooled off quickly and both curves hit lows for the year in August, and again in early September.

Also in Fig. 5.9, the light lines, which indicate more buying than selling volume when they are above 100, had a general tendency to follow the whole volume curve. That is, when volume was decreasing, buying was also decreasing, and when volume

* Croxton and Cowden, *Applied General Statistics*, 3rd Edition, Prentice-Hall, Inc., Englewood Cliffs, N.J., 1967.



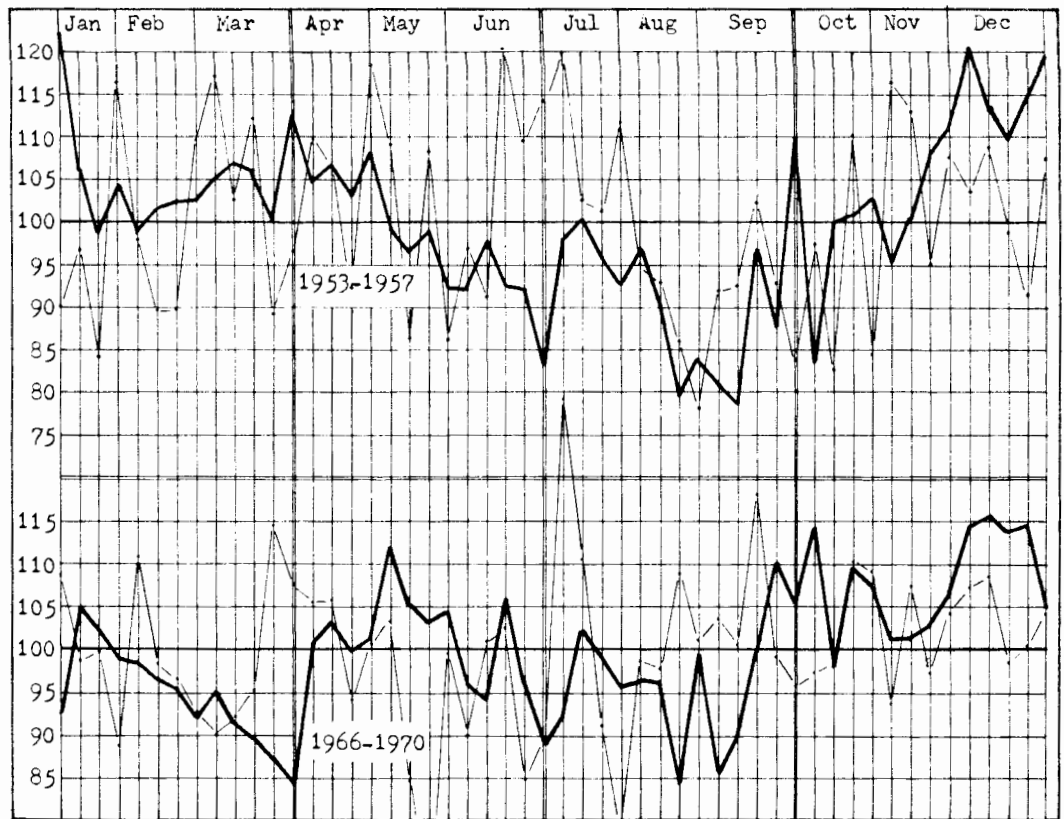

Fig. 5.9—Weekly volume in two disparate 4¼-year cycles, expressed as a percentage of a five-year average volume figure.

was increasing, there was also a general increase in buying volume. As we can see, then, buying volume in general tends to follow the increase and decrease in the quantity of total volume, as represented by the heavy line.

The cyclical pattern in volume figures

Fig. 5.9 also reveals a cyclical pattern of volume. That is, we can see that there is a well-defined low in both volume curves at the end of August and in early September. The September low, probably, has a relationship to the Labor Day holiday and the late August low is no doubt related to vacations and long weekends in the hot month of the year. The intriguing part, however, is that if we measure six months ahead of the August–September low, we find we are close to the February–March low area which is generally not as deep as the fall low, but, like it, is followed by a substantial increase in volume into April and early May, or a period of about three months.

The same is generally true of the final low volume period in the year. From early September, volume has a tendency to increase through December and then decline toward the February–March low. When we add this up, we can see that the result is



a perfect opportunity for the 25-week cycle to show itself. If we look again at the charts of Figs. 5.5 and 5.6, we can see that the Dow did exhibit the same tendencies, especially if we allow for a little carryover. In 1953, the Dow troughed in September, hit a small low in September 1954, made a double pullback in March and October in 1955 and followed similar patterns in 1956 and 1957. In the second chart, the Dow troughed in early October 1966 and in August 1969. In this chart, however, we see that the March–April lows were much more frequent. That is, there was definite weakness in the first quarter of 1968, in 1969 and again in 1970. With a slight change in the volume pattern from year to year, then, we can see that the Dow has tendencies to make lows in the first quarter and again in the third quarter of the year—because of the tendency to low volume in those periods of the year.

At the bottom of Fig. 5.6, we can see that the volume pattern in the lower portion of the chart also has a tendency to follow the seasonal pattern. Since these are simple five-day total figures, there is no statistical warp in the volume pattern in this chart.

Referring again to Fig. 5.9, the light lines in the chart indicate buying volume, so it is evident from the chart that when volume is below average for the year, there is a strong tendency for buying volume to dry up with the volume total. For instance, in the 1966–70 average, buying volume hit a low in the first part of February and again in early March. Volume increased somewhat in the second quarter, but there was again a drying up of volume beginning in late May, a surge into July and another sharp drop at the beginning of August. From here, the upward surge of buying in the fall months is evident in the chart. In the 1953–57 chart, we can also see the decline of buying in the early months, an upward surge of buying in March and a decline in late May. Also the August–September lack of buying is clearly evident, as is the upward push in November and December.

Now we can see, from the volume figures, that there is a reason for weakness in the market in February–March, May–June and again in September–October. If we check back through the charts of Figs. 1.8–1.11, we can see that the Dow demonstrates tendencies toward weakness in these months. For instance, in Fig. 1.11, the 1949 low came in June, the 1953 low in September, the 1957 low in October, the 1962 low in June and the 1966 low in October. Within the cycles, there was weakness in July 1950, in February 1957, in September 1959, in March and September 1960 and, of course, the sharp June drop in 1965. From the charts, then, we can see that the three weak periods in the market each year are caused by the drying up of buying volume when overall volume drops.

The seasonal-cyclical pattern of volume in the 1966–70 market

Since markets come down when there is less volume, it follows that markets go up when there is more volume. This is evident in Fig. 5.10, in which we see the movement of the Dow average expressed as a percentage of its own 52-week moving average and whole volume (the lighter line) expressed in the same manner, so that the two curves are statistically the same.

At first glance, we notice that the Dow had a swing of about 12 percentage points (righthand scale) above the average and about 18 points below. Volume, on the other



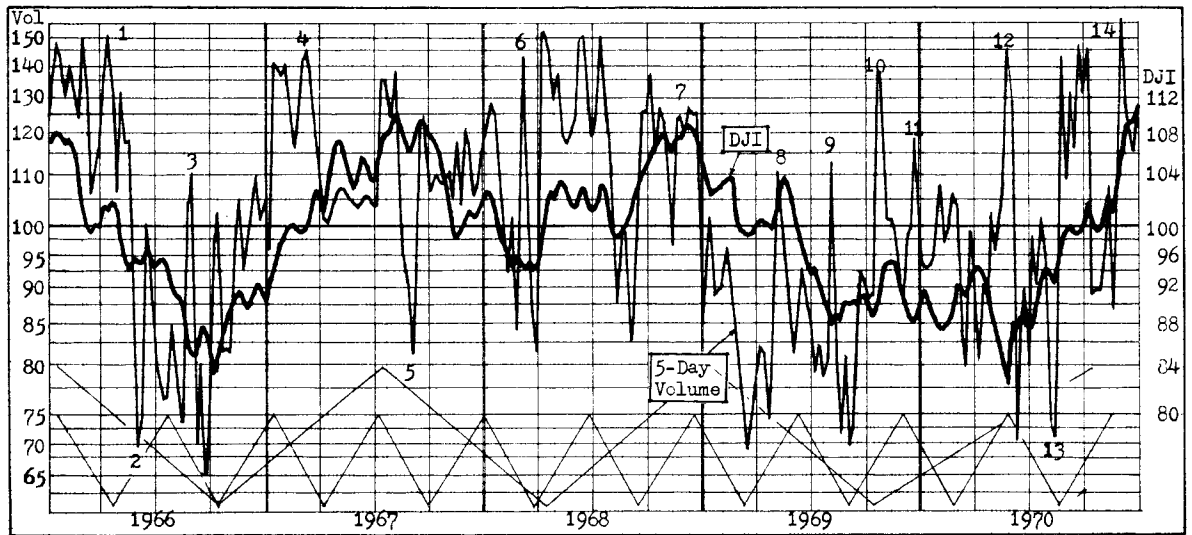

Fig. 5.10—The DJI expressed as a percentage of its own 52-week moving average, and whole volume expressed in the same manner.

hand, swung much more widely, reaching 150% of the average on the upside and declining to 65% on the downside. We can see that, in general, there was good correlation between the overall movements of the two curves, so that the Dow moved down as volume declined and moved up as volume increased.

We can also see that there was good evidence of the 25-week cycle in the Dow track, and especially in the downward spears of volume throughout most of the time. The 78-week cycle is also evident in the trough of every third speardown of volume. The overall shape of the curves indicates the presence of the $4\frac{1}{4}$ -year cycle, even though the downward track was bobtailed.

To make identification of the points a little easier, we have numbered those we wish to point out in the chart. First, at point 1, we see that the push of volume was responsible for the increase in the Dow above its trendline in the second quarter of 1966. Volume declined in total with the Dow from point 1 to point 2, and a selling climax of sorts developed as the Dow approached its first bottom in the third quarter at point 3. This was followed by the actual low of the market at the end of the third quarter and the subsequent increase of the volume total to point 4. By comparing the Dow with the track of the 25-week cycle at the bottom of the illustration, we can see that the peak of volume at point 4 coincided with the topping of the 25-week cycle at this time.

From point 4 to point 5, we see that volume, except for a single thrust, was declining, but the full decline of the Dow did not occur until volume increased in a movement that lasted into the first quarter of 1968. There was also another selling climax of sorts which occurred at point 6, and this apparently resulted in an oversold condition, since shortly afterward the Dow started its ascent to the 1968 top at point 7.



Now it is interesting to note that the percentage of volume above its trend was lower at point 7 than at either point 1 or point 4—an indication that, although the Dow was near a peak, the push of volume was declining.

The drop to the 1969 lows was marked by two selloffs at points 8 and 9 and an optimistic rush to buy at point 10. This was followed by another selloff at point 11 and a general decline in the Dow until the wide selloff which came at point 12 just prior to the 1970 cyclical low of the market. Those of us who were puzzled by the August 1970 pullback of the average can see that it was due to the rapid decrease of volume at point 13 and that the rally late in the third quarter was due to the push of volume, but also volume did not really get going until the final stage of the 1970 market at point 14.

There are other things visible in the chart, too. First, we note that the deviation of volume from its trendline topped in all instances close to 150 and that the lows were marked at about the 65 marker, with a few exceptions. Volume thrusts, then, also are subject to the relationship of balance between forces—buying and selling volume—since both the peaks and the troughs were 50% away from the trend at 100.

At the bottom of the chart, in addition to the 25-week cycle, we have traced a mechanical picture of the 78-week cycle, using the 1966 low as the timing point for the beginning of both cycles. From these tracks and the volume oscillations, we can see that in both instances volume closely matched the troughing of both cycles. This is particularly noticeable at the end of the first version of the 78-week cycle in 1968, and again at the second troughing in 1969. We can see good evidence that volume swings also with the 25-week cycle by matching the volume troughs and the track of the cycle at the bottom of the chart.

In this chapter, we have seen the rudiments of cycle forecasting and the techniques involved in using the advances curve as the basis for cycle forecasting. We also saw that volume was seasonal in form as well as demonstrating cyclical characteristics at the same time.

We also may have noticed that we did not really consider volume as part of the predictive process, or that volume curves, when they were shown, were consistently in short, five-day totals. There is a reason for this and it is, basically, that lag is much more prominent in volume curves than in advances curves. That is, while advances operate in a universe and, hence, cannot build to large values over a long period, volume is like price and can build to long, large totals. Because of the buildup of values within a moving total, then, the longer volume totals exhibit about the quantity of lag we expect—or about half the length of the moving total.

Now maybe we are just lucky that there is little or no lag in our calculated TORQUE values and the Dow average, since we cannot really ascribe a reason for the results, but we know, from experience, that the movements of the two are closely correlated in time. Whatever the reason, however, we know that we can use long moving volume totals to match the advances totals for establishing TORQUE values.



but that, for predictive purposes and for a visual representation of the action of volume, it is better to use the little five-day total which has negligible lag.

In the following chapter, we shall study the effect of cycles on individual stocks and, hopefully, show you how to benefit from stock market cycles. The problem is complicated, since, with individual stocks, we have other factors which affect the stock besides cycles, but we hope to show you that all individual stocks are subject to the swing of the cycles.



How to Profit from Stock Market Cycles **6**

Previous writers, in explaining the Dow theory method of market analysis, used the action of tides and waves in the ocean as a simile for the large and small swings of a market average. They were probably unknowingly talking about cycles in the market, so the description is also an apt one for cyclical swings.

The same sort of observed motion was the basis for the Elliott Wave Principle, except that Elliott took note of the small swings, or wave action of the market, as being part of the larger overall movements, while Dow theory followers were instructed to ignore the small swings and concentrate on the larger swings. In modern market analysis, analysts are divided into two schools, the fundamentalists, whose work is basically long-term and the technicians, whose work is basically short-term.

Of all previous market researchers, the late R. N. Elliott came closest to the truth, since he recognized that both long- and short-term swings are part of the same movement. That is, as Elliott noted, the small swings are an integral part of the large swings. If we consider that the long cycles in the market are like an ocean tide, rising and falling at regular intervals, and the small cycles in the market are like the waves in the ocean, rising and falling (1) from their own causes and (2) rising and falling with the tide, perhaps we can understand more easily why prices in the market reflect both movements at one time. Prices are flotsam on the surface of the market.

Now action of this type—two directions at once and often opposing—is difficult to understand, but, if we keep in mind that there are basically two kinds of cycles, long and short, and use the long ones to give us perspective from which to judge the



short swings, and use the short ones to give us perspective from which to judge the long swings, we can do very well in the market.

As we will see, most stocks have long swings of price in concurrence with the long cyclical swings, and, in order to profit from these swings, it is obvious that we should buy stocks at a trough and sell at a peak. It is also obvious that we should buy on the basis of good fundamentals for the long pull but not so obvious that we should sell at a peak, almost regardless of fundamentals, since earnings are also cyclical. In addition, for the short term, we should buy at a short-term cycle trough on a technical basis, and also sell at a short-cycle peak.

I—Cycles Tell Us When Stocks Are Cheap, When They Are High

It is a truism of the market that stocks should be bought when they are low in price and sold when they are high, but, until study of cyclical rhythms entered the market picture, it was difficult to determine even so elemental a fact as whether a stock was really cheap or high.

With cycle study, however, we know that stocks are cheap at cyclical troughs and high at cyclical peaks, since we know that most stocks swing in price with the cyclical rhythms. When we have established the times of troughing and peaking, gains become largely a matter of stock selection, since, when a trough has occurred, the trend of the market turns upward and all stocks—industrials, rails, utilities and over-the-counter stocks—feel the urge to rise in price. Similarly, when cycles are peaking, stocks are high in price and become candidates for sale or for selling short—because the urge to decline is at hand.

Nothing complicated can be reduced to its elements and remain completely true at all times, especially cycles, since cycles are not a simple $1 + 1 = 2$ affair. In addition, while all stocks will feel the tug of cycles, the reaction of individual issues to cyclical pull will vary. Some will rebound robustly from a cyclical trough and keep going. Others will rebound but fall by the wayside and still others will rebound only within their trading range, and thus be unprofitable.

It is obvious, then, that there are more factors involved in bringing down a profit in the market than simple adherence to cyclical rules. Other rules also apply in the selection of individual stocks, and the best cyclical results are obtained from buying stocks which are (1) in a good earning situation and (2) those which are the most responsive to cyclical pull. Sometimes both factors apply, at other times a single factor is sufficient to cause a stock to rise.

It has been estimated that about 25% of a stock's upward movement is due to the fundamentals of the stock, another 25% is due to the group to which the stock belongs and about 50% is due to market action. If we assume, as we have, that market action is the result of the upward and downward pull of market cycles, we can see that cycle knowledge is at least half as valuable as fundamental and technical knowledge about a stock. In other words, if we are successful in isolating a stock with good fundamentals, in a good group and responsive to cycles, we are much more likely to be



successful than if we pick a stock which has only one or two of these virtues. Of the three, however, cycles are the most important.

Investing should be a business proposition

If a merchant buys a dress he can't sell at full price, he keeps marking down the price until the merchandise is sold. If a gambler gets into a losing situation, he gets out as cheaply as he can. Both of them know you can't profit from a bad situation and that the longer you hold onto the problem the more likely it is to grind you down. Not so, however, with most investors in the market. If they buy a stock and it goes down, they hang on and hope. The next market swing may bail them out, but if the stock comes back to their purchase price, they still hold on in hopes of making a profit, and after a little profit they want more and more. Eventually, of course, they are back where they started—holding onto a losing proposition. This isn't a very businesslike attitude, to say the least.

Now that you have been introduced to cycles, you know that when you buy a stock and it goes against you in an upward cyclical swing, something is wrong somewhere, and most likely the fault lies in the stock you selected. Either the fundamental situation changed, if you worked at making your selection, or you made a bad guess, or you hit the wrong stock with your pin. In any event, if you select a stock when cycles are turning upward and the stock goes against you, the purchase was a mistake. Write off the loss as quickly and cheaply as possible and forget it. Get into a stock which will show you gains.

Selling a stock requires a decision—or the reversal of the decision you made to buy the stock—and “decision unmaking” is hard for many people, especially those who are unaware of cycles, and, also, especially if you have a loss. It is much easier to ride along with a small loss and watch it grow into a monster than it is to decide to get out immediately. Part of the problem is due to the fact that people buy a stock and right away it becomes part of the family. Selling it becomes like selling the family pet. Hard to do.

It also means the end of all your hope for the stock, since the sale, once made, is a finality. Stocks, however, are not pets or children, and a “bad” stock bears no resemblance to a naughty child who needs help to get over being naughty. Stocks have no feelings, they are only pieces of paper which represent your interest in a company, and they are inanimate. You can't help a stock go up in price by praying or even genuflecting, but people hold on regardless—because selling is the end of all hope.

On the other hand, if you look at your investments as a business, the decisions do not come so hard. You invest to make money, and you can only make money in the market (1) if the stock goes up in price after you buy it and (2) if you sell it to somebody. In both events, you are powerless to make the stock go up after you have bought. Any increase must come from other buyers who are willing to pay higher prices than you did in order to own the stock, and when a stock has had a sharp rise, a good question to ask yourself is “Would I buy it at this price?” If the answer is no, you have made half the decision to sell. The other half of the decision is “when.”

With cycle knowledge, the second half of the decision is easier to make. We try



to sell as close as we can to a cyclical peak, just as we tried to buy at a cyclical trough, and we prefer to lead the peak somewhat instead of trying for the absolute top for two reasons: (1) Like somebody said, "The only people who buy at the bottom and sell at the top are liars." (2) If we wait until buying desire on the part of the next owner has diminished, we are likely to have trouble getting rid of the stock at a price we want to take.

The first step to profits in the market, then, is to learn to make decisions on a business-like basis. Buy right, sell right, forget the remainders and never look back.

Markets of the future are likely to be cyclical markets

In case you aren't old enough to have noticed it, or if you really weren't paying attention, the 17-year period from 1949 to 1966 was a most extraordinary economic phase. During the swing, the U. S. economy blossomed tremendously, together with the fortunes of thousands of people, so that business statistics, with only four minor setbacks, climbed upward and upward to new high ground. The Dow industrial average also shared in the gains of the period, so that, at the 1966 bottom of about 760, the end of the upward trendline from the 1949 low of 160 was 475% above the low.

The growth of the economy during the 1949–66 period was the result of two things: (1) the subtle devaluation of the purchasing power of the dollar by inflation; (2) the Employment Act of 1946, which is basically the source of inflationary deficit financing of government budgets, if we discount military expenditures.

If we look at inflation in another way, we get a different view of what has happened. On January 1, 1934, the price which the U. S. Treasury would pay for an ounce of gold was raised from \$20.67 to \$35—an increase of 69%—so that on that date a new level of value was stated. That is, since gold has been pegged at a stated value since 1934, it is the only commodity that maintained a fixed value. Since gold also was pegged at \$20.67 from 1837 to 1934, we also have a previous fixed-value period which we can contrast. For instance, in January 1934 the Dow average stood at about 106, and, if we divide the Dow price by the \$20.67 price of gold, we arrive at a figure of 5.1 times the price of gold for the Dow stocks.

At the 1929 high of 380, the multiplier was 18.4 times and at the 1966 high of 1000, on the basis of \$35 gold, we have a figure of 28.6 times the price of gold for the stocks. Now, as we know, the 1929 high for the Dow average was unsustainable at 18.4 times the price of gold, and yet, by 1966, we had arrived at 28.6 times. At the 1966 low of 760, the multiplier was still at 21.7 times, and at the 1970 low of 630, it dropped to 18 times, or back to the previously unsustainable high level.

Now we hasten to add that we are by no means "gold bugs"—if only for the reason that it took 97 years for the 1934 change in the official price of gold to occur—but the fixed price gives us a stable figure which we can find nowhere else. We also hasten to add that we have no opinion as to whether a 5-, 18- or 28-times multiplier for gold is reasonable or sustainable, especially in light of the \$70 price for gold which the "free" market reached in 1972, and also in light of the credit structure which has been built up. In June 1962, for instance, *Standard & Poor's Stock Guide* showed American Telephone and Telegraph's long-term debt at \$7.631 billion and cash and equivalents



at \$1.516 billion. In July 1972, the same figures were \$22.282 billion debt and \$0.933 billion cash.

At any rate, the point we wish to make is that after a 17-year uptrend of 475%—or 27.9% per year—it is a little difficult to project such a trend to infinity. If we did, the 1983 troughing point for the Dow—from the 1966 low of 760—would be at 3600 DJI, and the peak, if we project across the tops, would be in the 4750 DJI area, which is a rather heady projection.

It appears, then, barring further inflation, and especially in light of the downward-to-flat trend which seems likely if corporate earnings do not dramatically top the \$50.7 billion reached in 1966 (the June 1972 figure was \$52.4 billion), that future markets are more likely to be cyclical markets than trendular markets. That is, without a strong supporting upward trend in corporate earnings, which went from \$18.5 billion in 1949 to the 1966 high—a 274% rise, or 16% per year—the swing of stock market price cycles will become increasingly important, and the relationship between fundamental and cyclical factors will change, with cycles becoming an even more dominant factor in stock prices.

The effect of cycles in a trendless market

When a cycle is operating along an upward trend, the troughs of each cycle also move upward. That is, prices at the troughs never reach the lows of the previous troughs but continue upward along the path of the upward trend, which acts as a cushion.

If trend is downward, the uplift of each cycle will be smaller than the downward leg, so that the only hope of getting profits from a long position lies in the short upward swing, and failure to close out the position will result in positive losses, since the rebound from a trough will not match the previous high, and the lows will be lower, according to the degree of the down-sloping trend.

When trend is flat, troughs of each cyclical swing will be at about the same level, as in the 1966 to 1970 swing, so that the upward progress of prices on the upswing will be matched or exceeded by the downward swing of prices for little net gain or a loss.

We can see, then, that in a trendless or downtrending market, cycles gain in importance since successive lows will be at or below the beginning. In other words, cycles are inevitable, and our only choice is to ride with the tide. Especially was this point brought out in the 1966–70 swing of the 4¼-year cycle. Those who rode stocks down in the 1969–70 leg of the cycle not only found themselves well locked-in at the bottom, but also, as it happened, in many cases locked-in almost beyond hope. What happens when a depressed stock which failed to rebound in an upturn is faced with another round of the same medicine as the market peaks again?

The only thing certain in the future is uncertainty. It is wise, therefore, to consider what might happen. When the price of gold was raised in 1934, the added value not only financed World War II but also started the whole upward swing which we believe culminated in 1966. A similar devaluation of the dollar against the price of gold would be likely to do the same thing all over again. That is, the \$70 price for gold which the “free” market reached, if adopted by leading nations, would provide a brand



new base for another upward swing of inflation. If it now takes \$38 to buy an ounce of gold, what will happen if it takes \$70?

The 1934 revaluation of gold was a 69% increase in price. A jump to \$70 gold would be an 84% increase. On the previous basis of a 69% gold price rise and a resultant 475% rise in the Dow, an 84% rise in gold would translate to a 578% rise in the Dow, or a Dow value of 5780 from the 1000 level. If this happens, all charts will have to be made on semi-log paper.

The teamwork between cycles and fundamentals

Like we said before, stocks gain in price for the simple reason that there are more buyers than sellers, which maybe sounds silly but really isn't, because at the moment of the transaction, there is more desire on the part of the buyer to buy the stock than there is desire on the part of the seller to hold onto his stock. The seller is experienced with the stock, the buyer isn't. The seller wants out, the buyer wants in, and one of the basic reasons the buyer wants in is that he expects the stock to rise in price after he buys.

What induces a buyer to want to buy? Fundamentally, it is because he knows that there is a relationship, however strained it may become at times, between price and earnings. That is, a stock rises because its earnings are showing—or are expected to show—an increase. If a stock sells at ten times earnings, or is earning \$1 and selling at \$10, if earnings increase, the price of the stock normally will go up proportionately. Sometimes, too, if the “story” is good, the price/earnings ratio of a stock will show even more dramatic increases than earnings alone, so that there is the added attraction of increasing P/Es to add to increasing earnings. These effects, of themselves, attract many buyers to a stock, but, like we said, the quantity of fundamental buyers is likely to be about 25% of those who will eventually buy the stock. Another 25% will come from buyers who figure this stock is the best of an attractive group, but half of the buyers attracted to the stock will be attracted simply because of cyclical market movement.

Technicians, in particular, are unlikely to be attracted to a stock until they can see the beginnings of a price movement. There is no point, of course, in buying a stock at \$10 when it has been at \$10 for the last 10 years, since the likelihood of it suddenly coming to life is remote. When it does start to move, however, it will attract buyers as long as the movement continues, especially if the recoils of price are relatively mild.

What makes a stock move? There are two reasons, both of which are of equal importance: (1) something has happened to the company so that the prospects of improvement are visible to fundamental analysts; (2) a cyclical upswing has begun. That is, even when the fundamental situation has changed, a stock is unlikely to make a very big move unless the movement is powered by a cyclical upswing. It is also unlikely that the good news will be widely recognized as such if cycles are going down, since good news seems to have much effect only in upward cyclical swings. Bad news has its maximum effect in downward swings. If the force of a cycle is upward, however, even bad news will be mostly shrugged off, and, if the force of a cycle is downward,



good news will have no more than a temporary effect on the stock price movement.

We can see, then, that maximum price movement of a stock is the product of favorable fundamentals and favorable cycles. There are times, of course, when either half of the team can cause price movements. Good fundamentals, when they are strong enough, or show evidence of change, can cause stocks to move anti-cyclically. Strong cyclical pulls can cause stocks with the strongest, or the weakest, fundamentals to move anti-fundamentally.

There is one thing about cycles, however. They always win out in the long run. That is, a stock may move anti-cyclically for a time, but eventually it must get back into step with the cyclical rhythms. Response to cycles is inevitable.

People always think of fundamentals as either bullish or bearish for the price of a stock. When a company announces increased earnings and the price of the stock goes down, the question is: "Why is the stock going down when earnings are going up?" The answer is two-fold: (1) Earnings reports are historical and reflect the past, not the future. (2) When a cycle is topping out, people become more skeptical of reports. They just don't quite believe that everything is going as well as it seems. Credibility, which is an ephemeral thing at best, loses out to skepticism, and vice-versa when cycles are changing direction.

Swing with long-cycle trends because you can't fight them

The idea of ownership is strongly imbedded in most people's attitude toward the market. The idea of owning a rising stock is beautiful, and, for those who bought Xerox when it was Haloid, or IBM or any of the other long-term growth stocks, buying and hanging on through thick and thin worked out exceedingly well.

As a result, most people approach the market with only one idea—to buy. Selling never enters their heads, and it comes as a shock to have someone suggest that selling is the only way you can profit from a stock—yourself, not your kids, under the present tax laws. This attitude makes it hard for many people to accept the idea of cycles, which, by their nature, alternate in direction. If you accept the premise that there are cycles in the stock market, you must also accept the idea that there is more than one direction to the market.

In the period from 1949 to 1966, when most stocks were trending upward, cyclical troughings could be accepted (as they were) as only minor movements in a long trend. Even so, however, some stocks remained cyclical and had large downturns when cyclical troughs appeared, and had minimal upturns when the direction of the cyclical influence turned upward.

Today, it seems to us, the mood of the market has changed. If the long-term trend has disappeared or become flat, cycles in the market take on additional import. In this sort of atmosphere, selling is going to become even more important than buying for the simple reason that no matter how hard you try, you can't fight a cyclical downswing without loss.

Now when a cycle troughs and turns upward, a majority of investors begin to



feel that the market is “oversold” and, therefore, likely to continue up. The mood changes from bearish to bullish almost as soon as the market itself turns. That is, as a cycle troughs and reverses, a few bulls appear in the sea of bears, and before long everything is bullish again.

When a cycle is rolling over the top of a swing, the atmosphere also changes—from bullish to bearish—and before long more and more people who own stocks are selling. After a while it is hard to find buyers, since everyone wants to sell.

The point is, bullishness is predominant all the way from a cyclical trough to the rounding peak, and bearishness is predominant all the way from the peak to the trough. If you are bullish in a down market, you are swimming against the tide. If you are bearish in a bull market, you are swimming against the tide.

The point is, bend with the cycles. You can't fight the tide of a down cycle any more than you can fight an outgoing tide in the ocean. You can move profitably only in the direction of its flow.

Commonality—the tendency of stocks to swing together

In his book, *The Profit Magic of Stock Transaction Timing*, J. M. Hurst states: “One of the characteristics of the principle of commonality is the manner in which cyclic component highs and lows occur at nearly the same time.” In other words, there is a known tendency for all stocks to trough together and rebound together, but, as we saw earlier, in the peaking area of a long cycle, there is also a tendency toward divergence, or for stocks to peak out at different times.

Earlier, also, we pointed out that in looking at the chart of a market average, it was often difficult to get much of the picture of individual cycles—except at their common troughing periods. That is, cyclical influence is stronger when stocks are troughing and rebounding from a trough than at any other time in a cycle, and when several cycles are troughing simultaneously, the influence is greatest. In between, it's often like a tide in a choppy sea. There is so much wave action present that the undertow of the outgoing tide is difficult to isolate, until suddenly it seems the waves are breaking on an empty beach.

So it is with cycles. The tug of the long cycles is often hardly visible in the track of an average because the track of the long cycle is covered up by the wave action of the shorter cycles. As a consequence, it is only when the long cycle is troughing, and the short cycles are troughing also, instead of fighting the troughing movement of the long cycle, that the result of the long cycle is clearly visible.

Now at market peaks, as we saw earlier, the situation is different. At a major market rebound from a trough, all of the cycles are pulling up together. The long ones and the short ones are all going the same way. After a while, however, the short ones have peaked and are in opposition to the long cycles, since, after their peak, the short cycles are trying to reach their next trough. If the long cycle is dominant, the short cycles won't make it clear down, but they will reduce the upward rise of the long cycle.

It's like a tree full of apples. They don't all ripen at the same time. Some ripen early, some ripen late, so there is a season for ripening instead of a ripening day. The



same with stocks. Some stocks are sympathetic at times to some cycles and unsympathetic to others, so some stocks will peak with the short cycles and some will peak with the long cycles, and some will peak in between.

Convergence/divergence at work in major market averages

In Fig. 6.1, even though it is a monthly chart of the major market averages all plotted on a single sheet (thanks to Three-Trend Cycli-Graphs), we can see the principle of convergence/divergence illustrated. At the market troughs in 1949, 1953, etc., we see that all of the averages troughed in, or close to, the same month at each of the occurrences. Also, especially in the 1962 and 1970 troughs, we can see that the averages declined sharply over a two-month period, illustrative of the big drops in price from a majority of stocks within the averages.

Now the averages portrayed are highly diversified. The smallest one is the largest of the Dow Jones averages, the 65-stock average. Then we have the Standard & Poor's 500-stock average, the National Quotation Bureau's O-T-C average and, finally, the New York and American Exchanges' indexes. The five averages cover a wide variety of stocks of all types—from the big corporations of the Dow average to the small companies incorporated in the NQB average. Yet, in the illustration, we can see that all stocks in all averages acted in about the same way at each cyclical troughing of the 4¼-year cycle.

The commonality principle is also evident in the overall illustration. With few exceptions, each swing of the 4¼-year cycle resulted in parallel tracks by each of the five averages. What differences there were came largely near the centers of the cycle paths, so that, in the troughing moves and in the rebounds from the troughs, there was close commonality of movement, or convergence toward a narrow trough.

In between the troughs, however, we can see the divergences between the long and short cycles. For instance, about every sixth quarter, we can see evidence of the troughing action of the 78-week cycle, and, from the choppiness of the averages, particularly in the 1950s and 1960s, we can see evidence of the smaller cycles. In the figure, also, we can see how the small cycles are incorporated into long cyclical swings. For instance, if we believe there is a 34-year (?) cycle in the market, we can see that the entire swing from 1949 to 1966 was an upward leg of the cycle. That is, from 1949 to 1966 the trend of the market was upward, but, except for the NQB average and the ASE index, we can see that the 1966–70 cycle was different from those which had preceded it. On the basis of the 1966 and 1970 lows, we can see that the trend, or long-cycle swing, has changed and appears to be headed down or to have flattened out.

Within the long 17-year swing of the market we can clearly see the four swings of the 4¼-year cycle which add up to the 17-year length. In addition, on occasion, we can see that three swings of the 78-week cycle fit into the 4¼-year cycle, and, from previous chapters, we know that the smaller cycles are present also.

Now we can get an idea of why cycles appear to be so complicated. Everything is working at once. The long cycles are making their long swings and the short cycles are making their short swings, and the middle-sized cycles are beating to their middle-



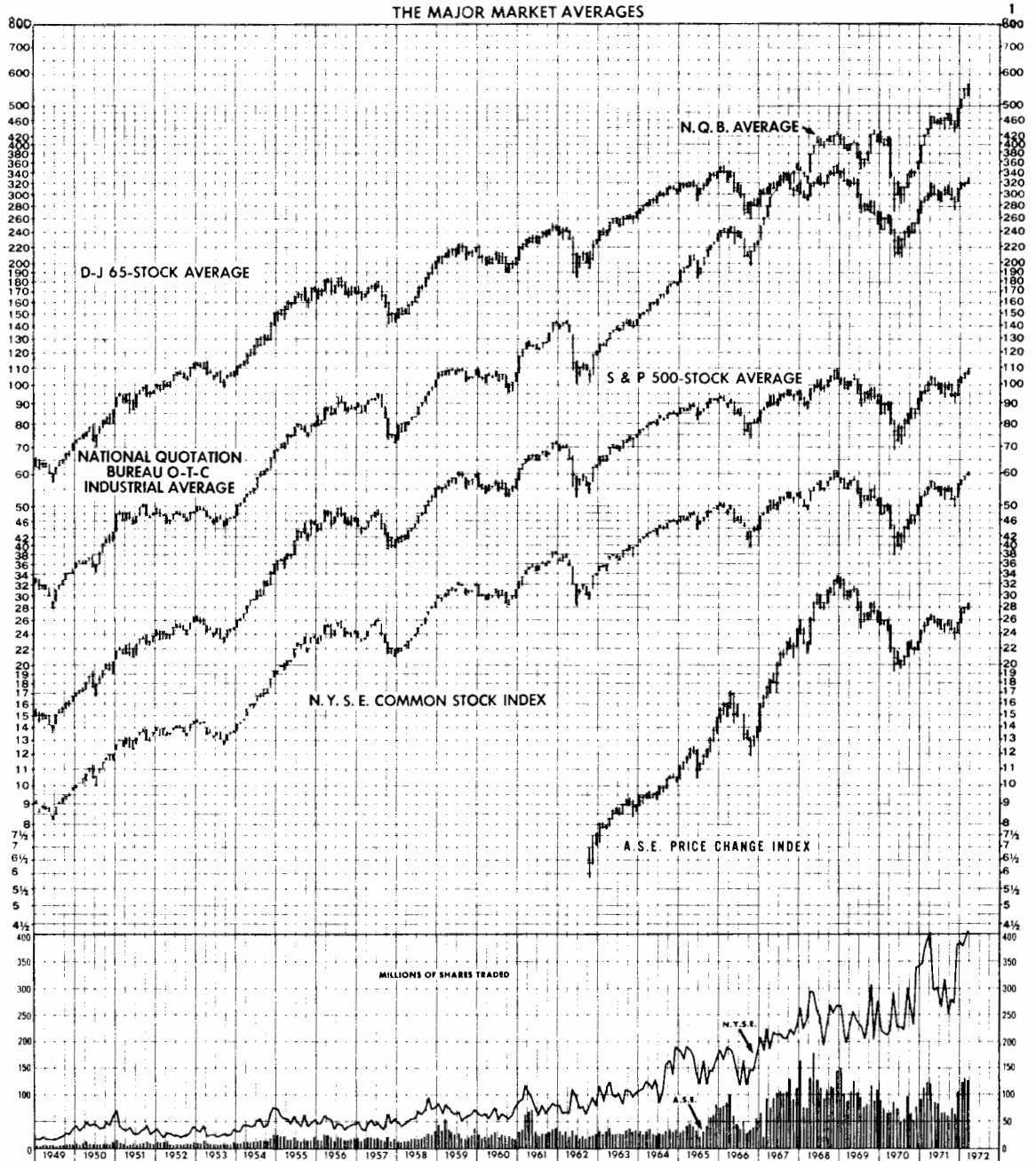

Fig. 6.1—The major market averages in the period from 1949 to 1972.

length rhythms—and the whole thing is expressed in a single concrete figure, the price of the moment.

A single price for a stock, then, expresses not only the sum of all fundamental knowledge and technical knowledge, but also the sum of the effect of all the rhythms which are beating in the market.

Individual issues indicate that cyclical pull is always present

Now when we say that the price of a stock equals the sum of all knowledge and the sum of all rhythms, we don't mean that in a literal sense. The price may reflect the sum of all knowledge, but the price may not be entirely the sum of all rhythms, because stocks are individuals and cycles represent the "average" stock.

In consequence, we cannot assume that individual stocks are always in tune with the rhythms, especially since we know that the rhythms are not always in tune among themselves. For instance, since our cyclical measurements have as a base the number of stocks which advanced each day, we are measuring the tendency of most stocks toward movement, but we may or may not be measuring a certain individual. That is, if the number of advances one day is 700 and is the same number the following day, it does not follow that it was the same 700 stocks which advanced on both days. Most of the 700 stocks on the first day also advanced on the second day, but an individual stock may or may not have advanced for two days.

The result is that while cycles express the tendency of all stocks to movement, we must be aware that some stocks are going to be on a diverging course. This is illustrated in Fig. 6.2, which is made up of stocks selected from Three-Trend Cycles-Graphs. It includes a growth stock, American Hospital Supply; a cyclical stock, General Foods; a railroad, Southern Pacific and a utility, Commonwealth Edison.

At first glance, we can see that over the 12 years illustrated (1955–66), all of the stocks demonstrated a tendency to rise and fall with the 4¼-year cycle swings from 1957 to 1962 and from 1962 to 1966, and to decline as the cycle was troughing. All four of the stocks, diverse as they are, were in general agreement with the swings of the cycle.

We also can see, however, that the response of each stock was different in detail from the response of the other stocks. American Hospital and General Foods, for instance, both rose from early 1958 to reach a high in 1961. American Hospital, however, really started its move in November 1957 while the low in General Foods was in February 1958. American Hospital dipped in 1959–60 with the pull of the 78-week cycle, but General Foods only went sideways with the cycle. American Hospital peaked out in April 1961, followed by a second peak in February 1962 while General Foods peaked out a single time in November 1961.

There are also similarities and divergences between Southern Pacific and Commonwealth Edison. Southern Pacific was quite responsive to most of the smaller cycles as well as the long cycle during this period, but Commonwealth Edison was largely unresponsive to cycles of less than the 4¼-year length. In the 1962–66 version of the 4¼-year cycle, Southern Pacific responded about as it had to the first cycle, but Commonwealth Edison was largely unresponsive to the second cycle, except for the



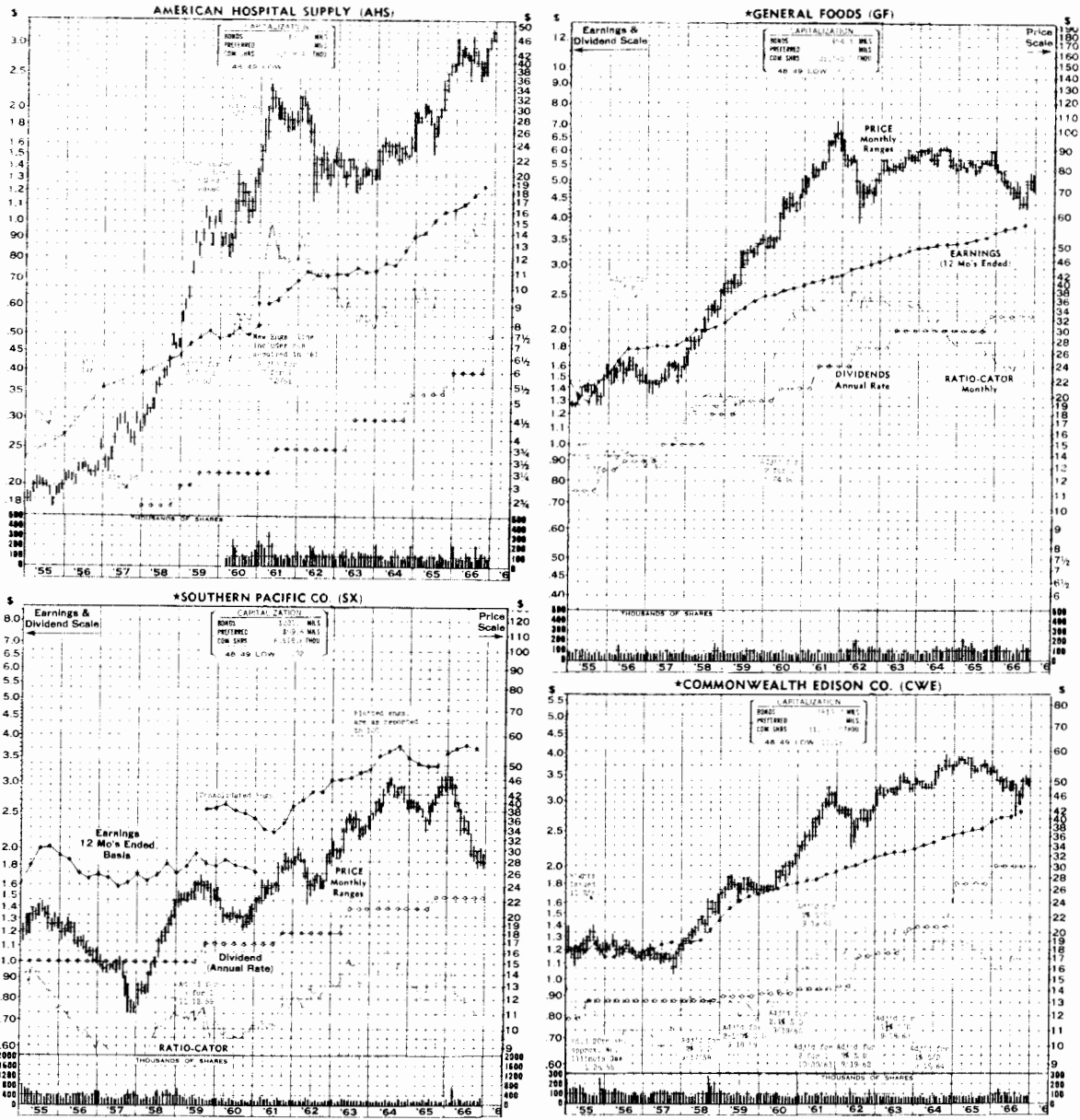

Fig. 6.2—The commonality principle—four diverse stocks all tend to rise and fall with the long cycles.

cyclical troughs in 1962 and 1966. The same general performance, in response to the 1962–66 cycle in relation to the earlier one, was evident in the tracks of American Hospital and General Foods. General Foods was “tired” in the second version and American Hospital also moved more slowly.

In Fig. 6.3, we have a chance to examine the four stocks’ response to a third

version of the 4¼-year cycle—the one from 1966 to 1970—and here again we can see differences in the stocks. American Hospital continued its upward move with hardly a dip at the 1966 trough but with a large dip at the 1970 trough. General Foods was unable to reach its previous high (in 1961) and was hardly able to match the 1964 high. It mostly went sideways during the period of the two cycles.

Southern Pacific responded late in the final 4¼-year cycle, starting to move only

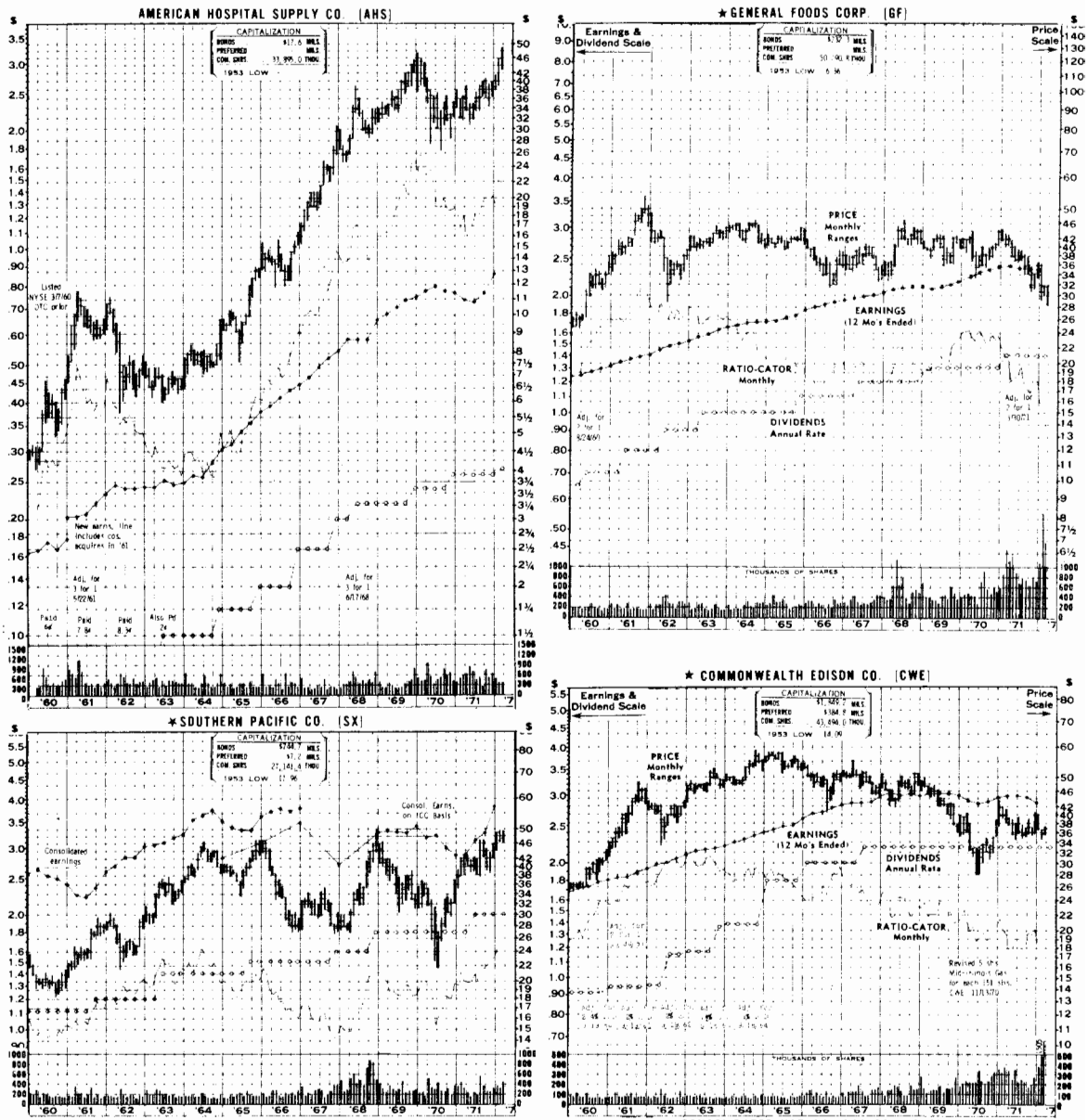

Fig. 6.3—The divergency principle—the same four stocks followed differing paths in the 1966–70 swing of the 4¼-year cycle.

in early 1968 and reaching a peak that same year. From the peak, the downswing carried it to a low which hadn't been reached since 1962. Commonwealth Edison hardly responded to the last cycle. It rose only a little above the 1966 low, went sideways-to-down until the cycle peaked in late 1968 and then started a rapid descent with the downpull of the cycle. In the drawing, we can see that, in this case, the two versions of the 4¼-year cycle combine to form an eight-year cycle—the first 4¼-year cycle being an upleg, the second being a downleg.

We find, then, that individual stocks have varying responses to the longer cycles in the market, and that, while the cycles we measure always indicate the general direction of individual stocks, the details are dependent on other than cyclical events. That is, while cycles are pervasive influences throughout the market of stocks, they are not the final determinant of a stock's movements. Part of the differences arise from the fundamental considerations of company earnings and outlook for the future, part arise from technical considerations and part arise from cyclical force.

Cycle response gives good clues to a stock's probabilities

We have seen from Figs. 6.2 and 6.3 that the response of individual issues—samples from a broad spectrum—is partly the result of cyclical influence and partly the result of other influences on the individual issue. Now how do we use cycles to help us measure whether a stock has performance possibilities?

The answer lies largely in the stock's response to the large and small cycles. As we have said earlier, you can't really judge a stock's performance without considering its performance in the light of all the cycles in our cyclical chord. The long, overall swing of the 4¼-year cycle gives us a good picture of what we can expect on the next swing, but the smaller cycles will tell us whether the stock is now living up to expectations.

In Fig. 6.3, we have a good sample of the response stocks can make, in the 1962–63 performance of American Hospital, and also in the response at the 1966 cyclical trough. As we can see, AHS was a laggard from the 1962 bottom. It moved up and down in a narrow pattern until the beginning of 1964, while the Dow and other stocks made more responsive moves. American Hospital wasn't a very good buy at this point.

Beginning with the uplift of the second 78-week cycle within the 4¼-year cycle, however, AHS began to move, and while it was still a laggard compared with the other stocks, it performed nicely until the mid-1965 low of the second 78-week cycle. From this low, the stock started the movement that carried it to its 1969 peak. From here it declined to the 1970 bottom with the troughing of the 78-week cycle.

One stock that was especially responsive to the cycles is Southern Pacific (Fig. 6.3). Here we can see that the stock responded to the 78-week cycle with troughs in late 1963, in mid-1965, in late 1966, in early 1968, in mid-1969 and at the 1970 low. At any of these dips, SX was a good buy for holding periods of about six months. That it was not a buy-and-hold stock is evident from the depth of the 1970 decline which was about an eight-year low.

Now the response of a stock to large and small cycles, which is evident in these examples, is also evident in daily and weekly charts of stocks and the smaller cycles.



That is, stocks respond at one time to cycles of 4¼ years and longer, to cycles of 18 months (78 weeks), to cycles of six months and smaller. Everything is wrapped up in a single stock's movements. The cycles combine into an overall influence but also retain their individual differences, and stocks respond the same way. They feel the tug of the long cycles and the short ones, and they also feel the tug of their own individual fundamentals.

It is evident, then, that since all of the cycles play a part in a stock's movements—and since these parts are evident primarily at cyclical troughings, as we can see—the measurement of a stock's ability to give us a profit cannot be limited to a single cycle or even a group of cycles. The whole bag has to be taken together.

When a long cycle is moving upward—or downward—it is the response to the tug of the smaller cycles which gives us clues to a stock's performance. If it remains responsive to the small cycles, it will most likely remain responsive to the large cycles, but, in an upward movement of the long cycles, if a stock fails to respond to a short cycle, its performance is suspect. This is particularly true when the long cycle approaches its middle distance and the shorter cycles are beginning to diverge from the path of the long cycle.

To bring profits down to the bottom line, then, we must pay attention not only to overall cycle performance, which represents what most stocks are doing, but also to the response of a stock to each of the cycles, and be alert when a stock fails to make the proper response.

II—The Dynamic Potential of Stock Market Cycles

Hopefully, by now, you have become acquainted with the simplicities—and the complexities—of stock market cycles in principle and are willing to be convinced that cycles can help you to profit in the market by riding long on the upswings of the cycles and being short, or hedged, or stabilized on the downswings. If you have reached this point, you have also reached the largest hurdle of all—learning how to think cyclically.

There are at least four roadblocks to cyclical thinking: (1) the calendar (2) the variations in the lengths of the same cycle (3) the interaction of long and short cycles, and the intertwining of all cycles and (4) your own ego.

First, we become so accustomed to thinking in terms of the arbitrary intervals of day, month, quarter and year of the calendar that we find it difficult to think in terms of cyclical lengths. Instead of seeing a cyclical swing as a complete unit, we tend to look at it as (1) a bull market of undefinable length and (2) an undefinably long bear market, or as two separate entities, since the bull market swing normally does not adapt itself to our calendarization of figures and the bear market swing doesn't fit very nicely either.

Besides being a handicap to our visualization of a cycle, calendarization of statistics makes it difficult to find source materials in adequate lengths. Most statistics books tend toward arbitrary breakdowns into years and quarters, and then into a lump of 10 years. By mid-1972, for instance, you could no longer find stock lows which were registered in mid-1970. You could find 1972 high-lows and you could find 1971



high-lows, but the 1970 lows are buried in 1960–70 figures. Either you keep your own figures or compile a library of statistics books.

Since we have already seen that cycles vary in length and come in packages, let's skip to the fourth roadblock—your own ego. People like to think that they control their own destiny. In prospect, it seems easy to buy a stock at a low price and sell it at a high price, but, in retrospect, we find that we seldom do. Instead, we let the cycles fool us into buying in the final rush to the top, when prices are jumping like mad and it seems everyone can become a millionaire in a couple of minutes, and then selling in the final rush to the bottom, when prices are falling fast and everyone seems destined for the poorhouse.

It is obvious, then, that without a study of cycles, our natural inclinations of hope (greed) and fear are always 180° off-course. As a result we buy when we should be selling—because we didn't buy when we should and consequently have nothing to sell at a top—and we sell at the bottom those stocks we bought at the top. We know in our hearts we are wrong, but time heals most wounds—and, besides, who wants to be stock-less? If we replace our emotions with cycle knowledge, we shall be buying when we should and selling when we should, and the rewards of swinging with the cycles are stupendous.

Now since, as we said, it isn't easy to get figures on which to base our assessment of the effect of cyclical pull, the effect is not obvious to most people. That is, very few people realize that cycles can cause a stock to make large percentage gains—and to take large percentage losses—because they never see the high-low figures contrasted over a long cyclical length. This section, we hope, will give you some idea of what the risk/reward ratio encompasses.

Large cycles have narrow swings but broad effects on stocks

As we have seen in previous chapters, long cycles have the least amplitude of cyclical swing but provide the greatest potential for capital gain. The reasons are: (1) The long cycles provide a trend for short-cycle movements, so profits can build from the short-term thrusts of the small cycles which, with a long cycle as a cushion, do not return to previous lows on each swing. (2) It takes time for profits to grow, which is why fixed-interval deposits carry higher interest rates than deposits subject to withdrawal at any time.

The potential for capital gain of long cycles is tremendous, in the right stocks, but generous even if glamor is a missing element. Glamor stocks can build up to 400, 500 and even 1000% increases from their lows, but even cyclical stocks will often go 50% or better in a cyclical upswing of the 4¼-year cycle. After all, of course, the 4¼-year cycle has about two years or better on the upside.

The percentage swings of the cycle itself don't look capable of such tremendous gains. The 4¼-year cycle, as we have seen, normally swings from about 95 on the downside to about 105 at the top of a swing, or covers an amplitude of about 10%. That is, when the cycle is approaching its upper asymptote at 105%, only 5% more stocks are advancing than are declining—over a two-year period. Now this is misleading when stated bluntly, because in a total as long as this, more than 5% of



the stocks are advancing, but because of the length of the total, the increasing number of advances is closely balanced by the large number of declines still within the totals.

Over a two-year period, for instance, the number of advancing stocks may reach 365,000, or an average of more than 700 stocks per day for two years, while declines will be about 350,000, or an average of about 670 stocks. Because of the sheer size of the totals, big changes, percentagewise, between the balance of advances and declines is impossible. Percentages of swing of the large cycles, then, do not tell the whole story of cyclical pull.

In Table 6.1, we try to tell the same story in a different way, with (mostly) cyclical stocks but with a sprinkling of stocks which picked up some glamor along the way. The table covers the 10-year histories of 10 of the Dow Industrial average stocks, with highs and lows reached by the issues during swings of the 4¼-year cycle—not the calendar.

Table 6.1—The percentage swings of 10 DJI stocks in two 4¼-year cycles, 1961–72.

	1962	1964	%	1966	%	1968	%	1970	%	1971–	%
	Low	High	Gain	Low	Gain	High	Gain	Low	Gain	72	Gain
			from		from		from		from	High	from
			'62		'62		'62		'62		'62
			low		low		low		low		low
Chrysler	9 ²	65	603	30	224	72	678	16	72	35	278
Kodak	20 ⁴	71	246	52	154	87	324	57	178	120	485
Nickel	21	40 ⁴	92	29 ⁴	40	47	124	33 ⁴	59	48	129
Int. Paper	23	38	65	23 ⁴	2	46	100	28 ⁴	24	38	65
J. Mansvil.	19 ⁴	32	64	22 ⁴	15	44 ⁴	128	26 ⁴	36	42	115
Sears	29 ⁴	77	151	44	49	75	154	51	73	115	290
Jersey	45	92	104	60	33	85	89	50	11	77	71
Swift	16	32 ⁴	103	18	13	36 ⁴	128	22	38	45	181
Westgh.	12 ⁴	33	164	20	60	39	212	27	116	48	284
Woolwth.	18 ⁴	33 ⁴	81	19 ⁴	5	38	105	25	35	44	139
AVERAGE			167		59		204		64		212

NOTE: All prices are approximate. All prices are adjusted for stock splits and dividends. Percentages are figured from 1962 low. Stocks are priced in eighths, so that the 9² price for Chrysler in 1962 is 9 and 2/8ths, or 9 1/4.

This allows us to see at a glance that cycles have a great deal to do with profitability. The prices quoted were taken from a Three-Trend Cycli-Graph chart of the stocks and so are approximations of the actual prices reached. Also, because of various stock splits and dividends, all prices are adjusted for changes during the 10-year period. This is one thing worth noting about charts. They tell you at a glance a great amount

of detail, which would take hours to dig out on your own, even though they lack precision.

As we can see from the table, the three upward swings of the 4¼-year cycle (and all the other cycles) from the 1962 low to the 1972–73 high were good swings, with price gains mounting to 167%, 204% and 240%, on average, from the 1962 low prices of the stocks.

The second obvious fact is that the cycle also swings down. From the 1964 highs of the stocks—and a 167% improvement over 1962 low prices—the prices of the 10 stocks decreased to only a 59% gain at the 1966 lows over 1962 low prices. At the 1968 high, the average of a 204% gain from the 1962 lows was another big plus for an investor, but at the 1970 lows, the 204% gain had reduced to a 64% gain since 1962. By 1971–72, however, the gain on the 10 stocks from the initial low was again over 200%.

Some of the stocks have been more volatile than others. Chrysler, for instance, gained 600% in the swingup to 1964 and again gained 600% in the swingup in 1968. In the 1966 downswing, however, nearly 400% of the gain was lost, and, again, in the fall to the 1970 trough, more than 600% of the 1968 gain was lost. Kodak also followed the same high-low-high pattern, and, lately, Sears, Westinghouse and Woolworth have also joined in the fun with large percentage gains.

We may be criticized for having selected only 10 of the Dow stocks for our table. We avoided, on purpose, many stocks which wound up with much less than a 62% gain from the 1962 low to the 1970 low, since we eliminated stocks which showed an eight-year cycle tendency to peak in 1966 and return to the 1962 lows in 1970. We also did not show the swings as percentages from the lows to the highs and again to the lows, since these statistics can be misleading. For instance, while Chrysler went up more than six times from 1962 to 1964 and came down to a roughly two-times multiple, the percentage would show as a 603% gain and only a 46% loss, since 30 is 46% of 65.

The point of the table, however, is not to make a study of the volatility of DJI stocks in cyclical upswings, but simply to show the tremendous possibilities for gain among even the blue-chip stocks of the Dow average. That is, even these big, cyclical-industry stocks can manage rallies of 50% or better from their lows at a cyclical trough. Even a stock like International Paper, which has had its troubles, can manage gains of 65% and 100% from cyclical lows when the cycles are swinging upward.

If we get into more volatile stocks, such as IBM, Control Data, Natomas, Xerox and others of like nature, the percentages can run to even more amazing figures. So amazing, in fact, that they are hard to believe. Would you believe, for instance, that Xerox rose more than 1400% from 1962 to 1966 and that it declined to only a 700% gain from 1962 at the 1966 trough? And other less-well-known stocks have done even better.

The 78-week cycle also has lots of cyclical “punch”

As we move up the cyclical scale from low-frequency (long) cycles to higher-frequency cycles, we find that the profitability decreases somewhat as cycle length decreases, but, on the other hand, the exposure to risk also decreases.



For instance, within the structure of the 4¼-year cycle of 221 weeks, there are three swings of the 78-week cycle. That is, during an upswing of the long cycle, there are 1½ swings of the 78-week cycle, so that, for 39 weeks the 78-week cycle is swinging up, for 39 weeks it is swinging down and for 39 weeks it is again swinging up as the long cycle moves up. On the first upswing of the 78-week cycle, both cycles are moving upward. On the second leg, the 78-week cycle is moving down and the 221-week cycle is moving up. On the third swing, both are again moving up together. On the fourth swing, after the 221-week cycle's peak, both cycles are moving down together, followed by another opposing swing and a final swing in harmony.

Now especially when the 78- and the 221-week cycles are harmonious and moving together, some very good gains can be generated in the right stocks. Also some very good losses can accumulate on the downswings of this cycle.

In Table 6.2, we illustrate with some selected volatile stocks the percentage gains which are possible from this cycle. In the table, we study two recent swings, the first up from the 1970 lows to the early 1971 highs, and from the November 1971 lows to the highs in early 1972. Not all stocks on the list made their highs simultaneously, so that some hit their highs and topped out in February 1972, some in March and some in May, but all of them swung from the 1971 trough to the 1972 highs by the amounts shown.

Table 6.2—The percentage swings of 10 selected stocks on two upswings of the 78-week cycle in 1970–71, and also in 1971–72.

	July 1970 Low	April 1971 High	% Gain	Nov. 1971 Low	May 1972 High	% Gain
Bangor Punta	6 ³	15	135	8 ¹	17 ⁴	115
Berkey Photo	5 ¹	13 ⁶	168	11 ³	22 ⁶	100
Boeing	12	25 ²	110	13 ⁴	26 ⁴	96
Contin. Airline	8	19 ²	141	16 ¹	28 ¹	74
Gilbert FlexV.	9 ⁴	32 ²	239	17 ²	48	178
Global Marine	7 ⁷	21 ⁷	177	11 ³	25 ⁷	127
Gulf & Western	10 ⁷	31	185	21	44 ²	111
Sanders	7 ⁴	22 ⁶	203	8 ⁵	20 ⁵	139
Xtra.	13 ⁴	34 ²	154	14 ⁷	34 ⁷	133
Zurn	15 ¹	26 ⁶	77	16	37	131
AVERAGE			159			120

Stocks are priced in eighths, so that the Bangor Punta 1970 low is 6 and 3/8ths and the Berkey price is 5 and 1/8th.

From the table, we can see that all these stocks were “cheap” at the 1970 lows and high at the 1971 highs. Bangor Punta, for instance, was selling at a low of 6 3/8ths in July 1970 and climbed to a high of 15 in early 1971. That it was high at that price is evident, since it declined from the April high of 15 to a November low of 8 1/8th.



If you had bought at the high and sold at the low, you would have lost 45% of your original capital. If you had bought at the $8 \frac{1}{8}$ th low and sold at the May 1972 high of $17 \frac{1}{2}$, you would have had a 115% gain on your transaction, not including the in-and-out costs of doing business.

The same thing was true of Global Marine, which troughed in 1970 at $7 \frac{7}{8}$ ths and peaked in 1971 at $21 \frac{7}{8}$ ths for a 177% gain. From the high it receded to a low of $11 \frac{3}{8}$ ths, so if you had bought at the high and sold at the low, you would have lost 48% of your capital.

Of the 10 stocks, including Zurn—which did nothing much in the first upswing, having only a 77% gain—and Continental Airlines—which did nothing much in the second upswing with a 74% gain—the average gain is 159% for the first upward swing of the 78-week cycle and 120% for the second upward swing. In between was the “killer wave” which washed out nearly all of the original profits.

If you were trading for the long pull, you would also have had some nice profits at the 1972 high, but you would also have had some queazy moments at the 1971 low. For instance, in the two upswings of the 78-week cycle, Gilbert Flexi-Van would have given you a final profit of approximately 400% and Gulf & Western would have netted 296%.

Now we are not trying to whet your appetite, but simply want to show you some of the profit potential which can be the result of trading long-term with the 78-week and 221-week cycles in the right stocks, and also illustrate that even business-cycle stocks such as the DJI blue-chips can give you 50% or better gains in the swings of these cycles.

The 1966–70 swing of the long cycles and the performance of Control Data

In order that you may get some “feel” of what long cycle swings can do to a couple of glamor stocks, we illustrate in Fig. 6.4 the track of Control Data and in Fig. 6.5 the track of Natomas. Both charts are drawn on a weekly basis during the 1966–70 swing of the $4 \frac{1}{4}$ -year cycle, plus the 78-week and 25-week cycles, from the 1966 low to the 1970 low.

Even though this was not a very heady period, in comparison with earlier swings of the cycle, it still gives us a picture of what can happen to this type of stock in this type of market.

To begin with, the drawing is made so each bar represents a week’s high-lows, with the quarters of each year identified by the light vertical lines and the years by the double vertical lines. The cycles are then laid over the top of the stock’s track during the $4 \frac{1}{4}$ -year swing.

As we can see, Control Data had an immediate response to the upward tug of the cycles from the 1966 low. It started to move only four weeks after the trough of all three cycles, and it moved up for a whole year, going from \$30 to about \$165. At first the movement was gradual, but, in the second quarter of 1967, the stock commenced to move rapidly. When the 78-week cycle topped out in mid-1967, the stock hesitated only briefly and then continued its run until the end of 1967. Hope springs eternal.



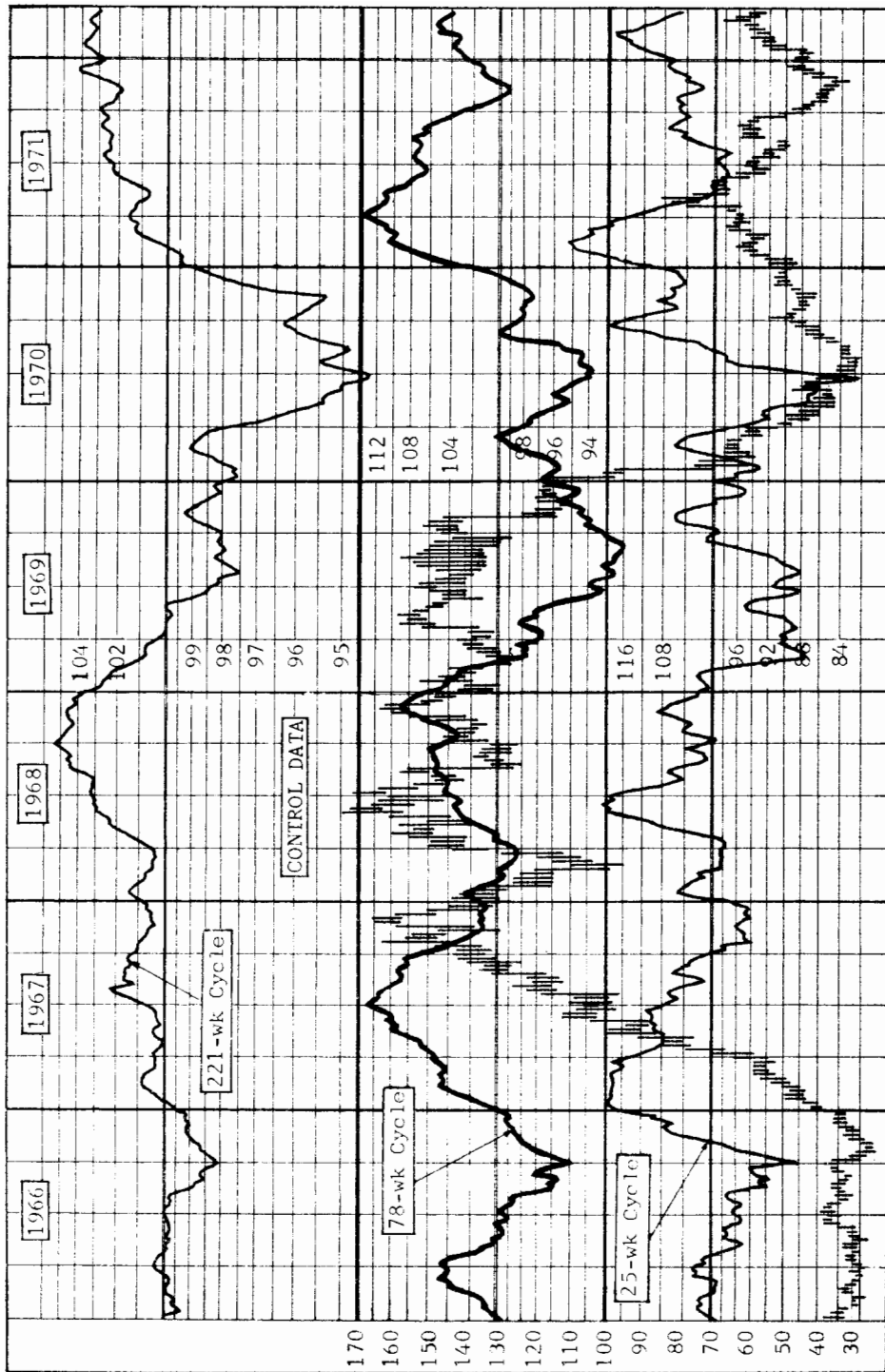

Fig. 6.4—The reaction of Control Data to the three long cycles, 1966–71.

It dipped finally in the first quarter of 1968 and troughed slightly ahead of the cycle. From the trough at about 100, CDA rose sharply with the cycles to a new high of more than \$170, troughed with the 25-week cycle and came to a second high at the 1968 peak of the 78-week cycle. While this cycle moved down, CDA went sideways until the final quarter of 1969, when it started its rapid descent to the 1970 low, troughing in sympathy with all the cycles at midyear.

Now from the drawing, we can see that the stock was, at various times, responsive to pulls of all three of the cycles illustrated. At times, also, it was mostly unresponsive, but, in the final analysis, we can see that even though it resisted downward pulls at high levels for a long time, it still had to trough with the cycles in 1970. The pull of cycles is eventually inevitable.

We also can see from the chart that the stock was largely unresponsive to the upward pull of the cycles beginning at the 1970 lows, and, from fundamental reasons, we know that the stock was not the stock it once was. Even so, as we can see, it managed a pullback from the lows of 180%, moving from \$30 to about \$85 at the 1971 highs. It also had another nasty drop with the last downward swing of the 78-week cycle in late 1971, dropping back to 32 from the 85 high. If you are going to swing with the cycles, you must swing in both directions.

The 1966–70 swing of the long cycles and the performance of Natomas

In Fig. 6.5, we show what happened to Natomas during the same period. Natomas' move was quite different from that of Control Data, but it managed to put on a good show also.

When the cycles troughed in 1966, Natomas was anything except a glamor stock. It was described as the owner of American President Lines shipping stock and a gold-mining company. By 1971, the character of the company had changed to "holding company, shipping, oil and real estate."

As a cruise line company, Natomas did little in the early stages of the cycles, merely doubling from \$10 at the 1966 low to a high of \$21 in the final quarter of 1967. It troughed with the 78-week cycle in early 1968 and then doubled again with that cycle, reaching a high of \$42 in early 1969. Instead of retreating with the longer cycles in 1969, however, this stock got a big push from the 25-week cycle and smaller cycles and spurted up to a high of \$130 by mid-1969. From this peak, it answered the troughing call of the 78-week cycle in the third quarter, and, after another runup to \$100, moved down sharply to trough with the cycles only five points above its 1966 low in mid-1970.

The rebound from the 1970 low was also spectacular. It moved with all three cycles from the \$15 low to a high of \$100 in mid-1971, carrying a few weeks past the peak of the 78-week cycle, and then troughed again, this time at \$50 with the 78-week cycle. Now some people, we know, will say that the Natomas' movements were mostly anti-cyclical, especially the spurt up to its high in 1969 when the cycles were coming down. The answer is that, except for the spurt brought on by its Indonesian oil discoveries, the stock showed very cyclical tendencies during the period. Even here, if we consider that short cycles are as strong as long ones, we can find cyclical tendencies.



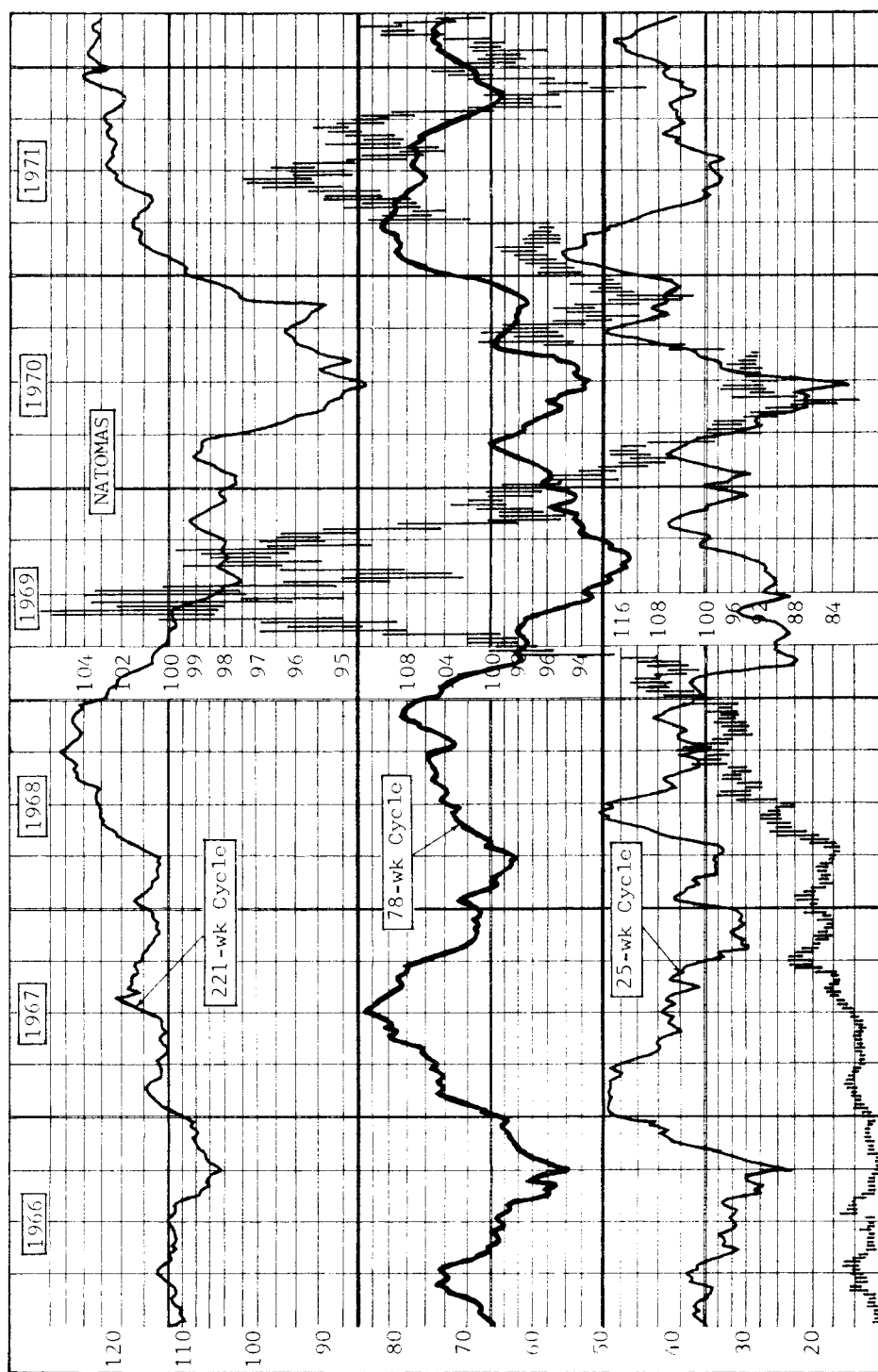

Fig. 6.5—The reaction of Natomas to the three long cycles, 1966–71.

The point is that we do not really expect to find a stock which will never waver from the cyclical tracks. There is no average stock, and, after all, the cycles express the center of a very large universe of all stocks, which either advance or decline in a day's trading on the NYSE.

There is also the point of what to do in a situation of this sort. Does it pay to speculate with a stock which moves like Natomas did in 1969, on, really, a rumor basis? The answer is no, unless you have gambling instincts. When a stock departs drastically from the path of the cycles, as this one did in its second quarter swing of 1969, it also departs from our yardsticks of value, since it is moving against the trend of the cycles.

The best move, in our opinion, is to track its movement with the short cycles, and, when it begins to show evidence of becoming cyclical again, buy or sell it in harmony with the trend of the market which the cycles illustrate. That is, except at the troughs of the 78-week cycle, Natomas largely moved against this cycle, but at the troughs, which are the strongest areas of cycles, it moved cyclically for a while. For instance, you could have made money in the pullback to the second 1969 high and you could have done very well from the 1970 low, but, with lack of guidance of the stock from the long cyclical influences, a stock which performs in this manner is dangerous to your capital. Play it only for gains with the short-cycle swings.

III—The Fidelity of Cycles Defined by TORQUE Analysis

There are three questions always present in the mind of any cycle researcher: (1) Does the cycle response to my methods portray the genuine thing or do my statistics sometimes indicate that the cycle is not genuine? (2) Is the cycle my statistics isolate a force that permeates its universe, so that a majority within the universe will respond to cyclical pull? (3) If I use the cycle for prediction, can I be assured that the response will be there? The answers really lie in the past, since the only confirmation can come from the extension of experience.

With our TORQUE method of cycle analysis, we get down to some very basic answers to the mystery of cycles. First, we worked out our theory on the basis that cycles were the third-dimensional effect of an underlying system which included two equal parts—price and volume. By equating these two into a single value, we recognize that price movements are not always genuine and that the best method of determining genuineness is on the basis of volume. If enough people will buy at a price, it is established as a real cyclical value, in the sense that it is genuine, not cheap. This is the picture which TORQUE analysis portrays: price has value in proportion to the quantity of buyers.

Second, as we shall see, the cycles we have isolated have a universality. That is, they permeate the whole market so that not only a market average shows indications of cyclical pull but all market averages do, as we saw in Fig. 6.1. Secondly, in the previous section, we saw that there was a cyclical effect present in the movements of two glamor stocks, and, thirdly, the effect includes not only glamor stock movements but those of other classifications.

Third, the principal value of cycles lies in the predictive possibilities inherent in



their predilection to rhythms, to their desire to oscillate from high to low and back again at regular time intervals. The real basis for judgment of our TORQUE method of cycle analysis, then, arises from prediction.

TORQUE analysis gives us third-dimensional perspective of the market. It measures the response of price in relation to the underlying force, volume, and also gives us vision to interpret the movements of price as being either cyclical or anti-cyclical. The cyclical movements are predictable; the anti-cyclical movements are not.

Now movements of a group of stocks, such as a market average, are predictable since the average offsets the unpredictable parts of individual movements. That is, it is too much to expect that all stocks will move cyclically at all times since there are other aspects which affect individual stocks. This is especially so if we consider that the cycles our methods portray are really a kind of "average," but, in the market, there is no such thing as an average stock.

There is also another aspect of prediction. If we predict, for instance, that the Dow average will hit 1000 and the average goes only to 975, is the prediction wrong? The answer, of course, is no, since the result is a matter more of definition rather than of error, if the Dow was at 900 at the time of the prediction.

With these thoughts in mind, let us see how a number of individual stocks have reacted to cycles in the market.

The response of an industrial stock, General Motors, to long-cycle pull

In order that we may assess the fidelity of the cycles in our cyclical chord, we have plotted the three longest cycles in the chord over the path followed from 1966 to early 1972 by three different types of stocks: an industrial, a rail and a utility. Since all three of these stocks trade on the NYSE and since our basic statistics, advances and declines and volume, derive from the NYSE, it follows that these representatives of the major classifications should swing with the cycles.

In Fig. 6.6, we see the movements of General Motors during the period. First, we see that the stock moved in general correlation with the big 221-week cycle in that it troughed with (slightly later than) the cycle in late 1966, travelled to a peak at the high of the cycle in late 1968, declined with the cycle to the cycle's trough in mid-1970 and then followed the cycle upward into 1971.

With the 78-week cycle, the stock troughed in late 1966, peaked in the third quarter of 1967, troughed in the first quarter of 1968, climbed to a second peak in the fourth quarter of 1968 and declined with the cycle until the third quarter of 1969. From here, the stock went down while the cycle went up, but the two got back into correlation at mid-1970. From this trough, the stock and the cycle climbed until the cyclical peak in early 1971, and declined with the cycle in late 1971. The stock's response to the pull of this cycle, then, was also good.

With the 25-week cycle, we can see that the stock also made an effort at correlation, by generally rising when the cycle rose and declining when the cycle declined. The match, however, is not as regular as with the other longer cycles, but, still, we can see an impulse to move with this cycle as with the others.

Now when we look at all three cycles together, we see that the correspondence



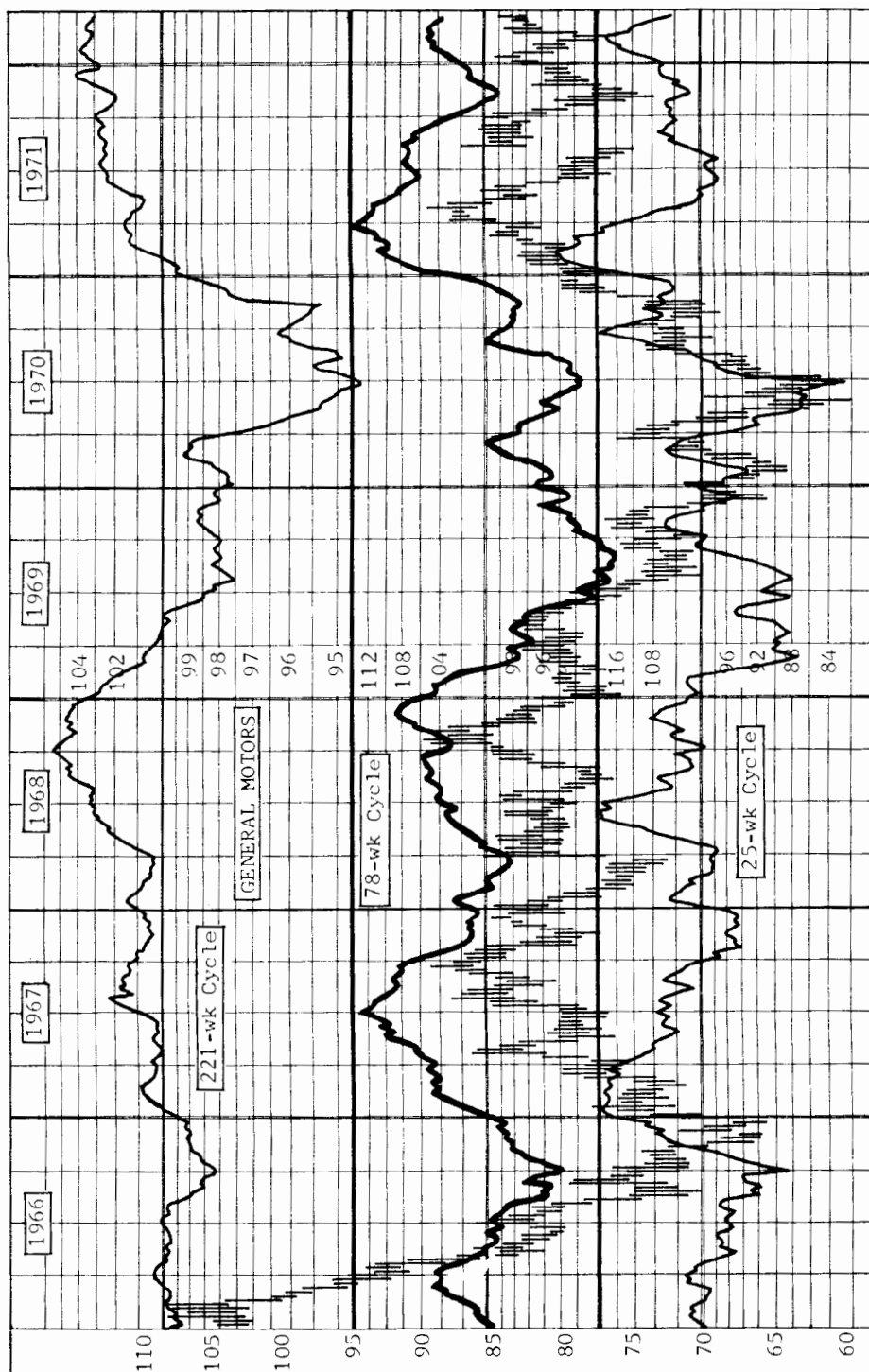

Fig. 6.6—The response of an industrial stock, General Motors, to the three long cycles, 1966–71.

of movement between the cycles and the stock's price was generally good. We can also see, in the illustration, that we have made the 78-week cycle track twice as heavy as that of the other cycles. This is because, in our opinion, the 78-week cycle is the kingpin cycle of this group. That is, being the central cycle, it reflects the movements of both the 221-week cycle and also the 25-week cycle. This is a strong cycle and also very handy to have around, since it provides swings long enough for long-term capital gains, because the swings tend to be about nine months long, and it also causes stock price movement of considerable proportion.

The response of a rail stock, Southern Pacific, to long-cycle pull

Railroad stocks have always been different than industrial stocks, even though at the beginning of the last century they were about the only stocks on the exchanges, and were, thus, the "industrials" of their era since trading prior to the advent of the rails was largely in government obligations.

Today, rails are freight carriers and are so tightly regulated that they enjoy little of their previous freedom. They are, thus, quite different from modern industrial stocks, and perhaps we might expect a little different response from these stocks to the pull of the cycles.

In Fig. 6.7, we see the price movements of Southern Pacific from 1966 to early 1972, and once again we find that the stock of this company tends to follow the long cycles.

For instance, SX troughed with the large cycle in late 1966, peaked with the cycle in late 1968 and troughed again in mid-1970. With the 78-week cycle, the stock rebounded from the 1966 trough, although weakly, peaked with the cycle in mid-1967, troughed again in early 1968 and peaked in late 1968. In mid-1969, it is interesting to note that the stock attempted a rally when the 78-week and the 25-week cycles were rallying and managed to make a couple of upward movements before the final 1970 trough. In the second half of 1970 and early 1971, SX moved almost exactly with the 78-week cycle and was strong in late 1971 when it refused to dip below its previous lows with the cycle.

We can also see in the movements of the stock the tendency for it to be sensitive to the swings of the 25-week cycle in its shorter movements.

We can say, then, that our representative of the rail group is also cyclical in the sense that it swings with the movements of the three largest cycles and its overall correlation is good. In this regard, we have noticed that, on occasion, the movement of the transportation average tends to lead the movement of the industrial by a few days. The rails seem to be more sensitive to changing conditions than the industrials, although not so sensitive as when the rail average contained only rails.

The response of a utility stock, American Electric Power, to the long cycles

Utility stocks are generally considered "money" stocks in that they are sensitive not only to their own fundamentals but also to the money market because of their extensive borrowings and because, especially in recent years, they have been forced to become frequent visitors to the money market.



Utility stocks have been trending down for several years. The Dow utility average hit a peak of about 165 in mid-1965 and a low of about 95 in 1970. This low slightly exceeded the low registered in 1962 when the stocks were in an upward movement. In general, however, utility stocks are considered as good havens for money in a downward market since the amplitude of their swing is generally a “dampened” version of the swings of more volatile stocks. Also, because their preferred stock issues are so closely held, there are really two different types of utility stock available. The common is the more volatile of the two and, because it trades more widely, is the faster moving. The preferred, on the other hand, trades in small quantities and generally at higher yields than the common. The preferreds, while hard to buy and sell, are good investments in a down market offering stability of price plus good yields.

In Fig. 6.8, we have plotted the price movements of American Electric Power as a background for the cycle tracks. Once again inspection leads us to the conclusion that the stock is cyclical even though its response is limited. During the 1966–68 upswing of the 221-week cycle, prices rose from the trough and then went mostly sideways until the peaking of the cycle. From here a gradual decline set in, aided no doubt by tightening money, and the stock troughed at less than 25 at the 1970 low. While there was an upswing from the mid-1970 low to early 1971, the stock mostly declined and then went sideways while the 221-week cycle pulled up. There is also some response to the 78-week cycle, and, perhaps, a little more to the 25-week cycle than we have seen, but overall we can say that the correspondence of the stock and the cycles is good if we acknowledge the downward tendency and the lack of volatility inherent in stocks of this sort.

Once again, it is too much to expect that every stock is going to answer the call of the cycles in an identical manner or even exactly match the cycle movements. What we have tried to show you in this section is that stocks, while individuals and subject to their own idiosyncrasies, tend to move together. These examples are neither the best nor the worst examples possible, but they are representative of the swing of stock prices to cyclical pull.

The response of General Motors to short-cycle pull

In Fig. 6.6, we showed the response of General Motors to the pull of the three long cycles in our cyclical chord and noted that the general response of the stock to long cycles was good. That is, the pattern of price movement of the stock was seen to combine the three effects of the three cycles into a series of swings up and down, with overall direction coming from the longest cycle and intermediate effects from the smaller cycles. We find, however, on closer inspection, that there is still something missing. That is, there are movements in the price of the stock over the period examined which were not explainable on the basis of the three cycles.

In Fig. 6.9, we have plotted, this time on a daily basis, the swings of General Motors over a two-year period—which gives us several swings of even the longest of the short cycles, the 10-week cycle. Since the period covers the stock from the middle of 1969 to the middle of 1971, we can see the reaction of GM to both the downward



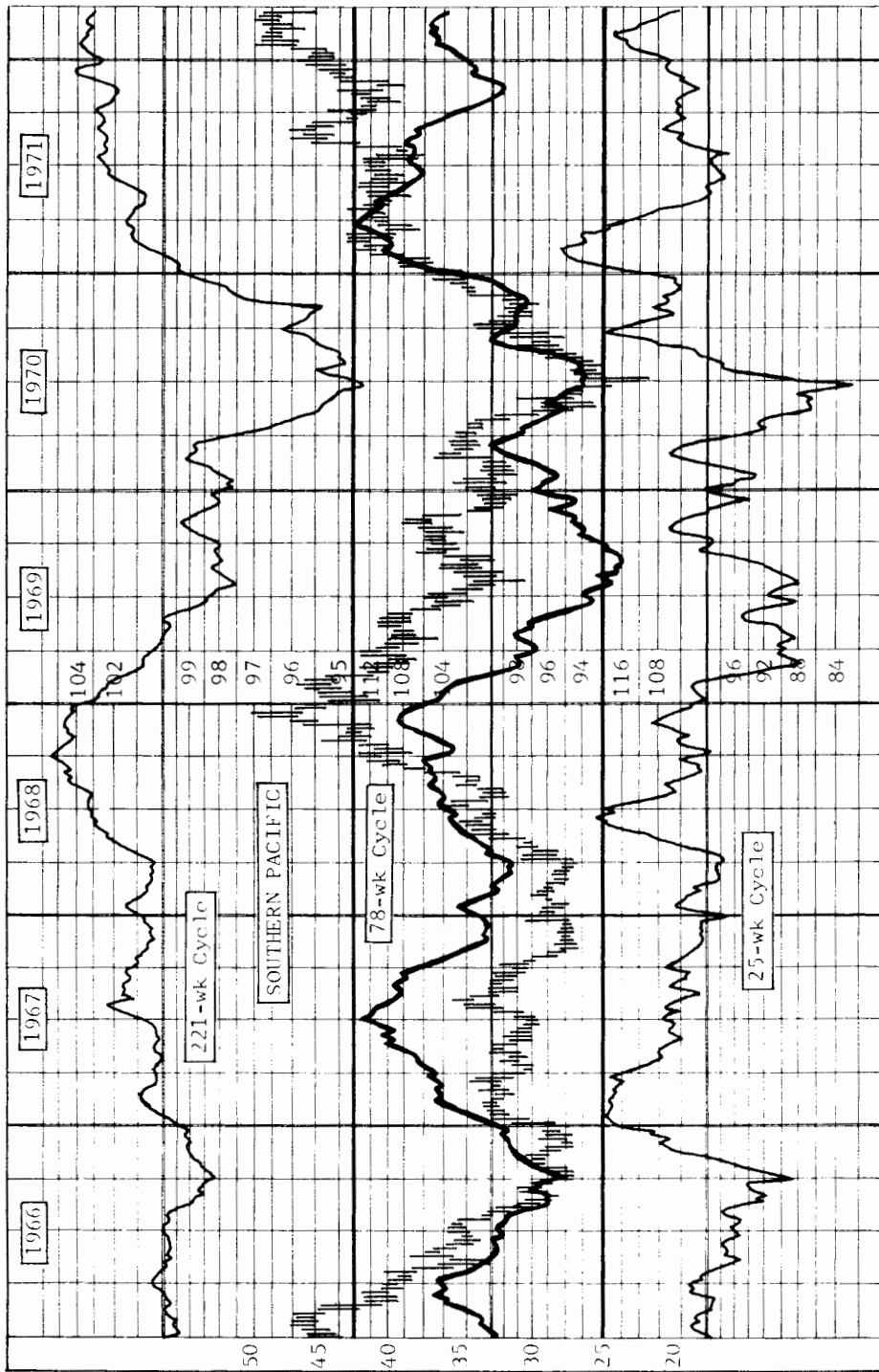

Fig. 6.7—The response of a rail stock, Southern Pacific, to the three long cycles, 1966–71.

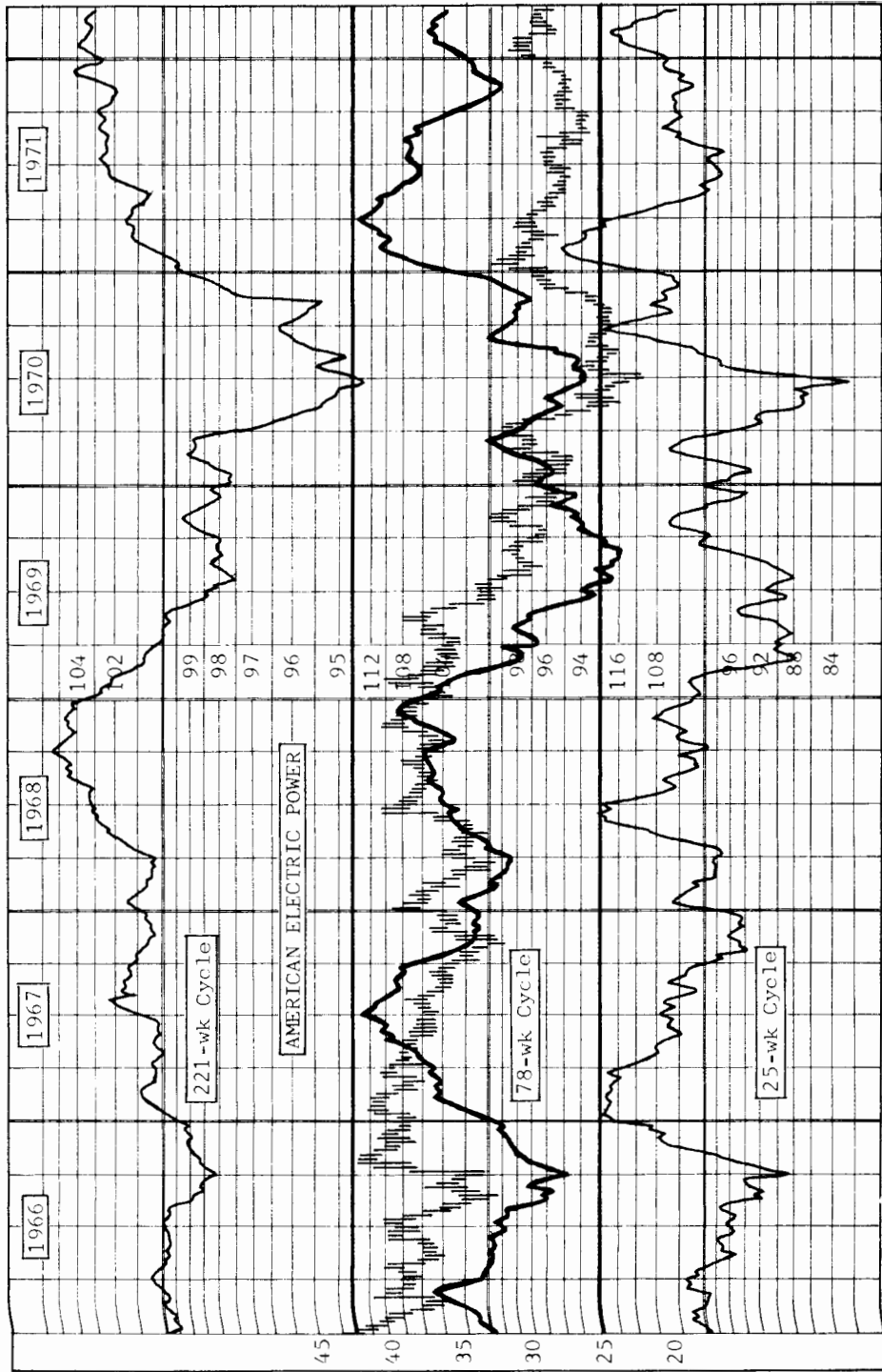

Fig. 6.8—The response of a utility stock, American Electric Power, to the three long cycles, 1966–71.

and upward swings of the long cycles, and also the reactions to short cycles in the upward and downward phases of the long cycles.

In the figure, the first thing we notice is that we have added a new cycle to those we have discussed previously. This is a cycle of about five weeks in length. If it looks like an afterthought, it is. When we completed research for this book, we found that our chord of five cycles appeared to have something missing. The missing part, we discovered, was the five-week cycle.

Since our objective then, as now, was to find a means which would explain *all* stock price movements, we were disappointed to find that most, but not all, movements could be accounted for by the presence of our five cycles. Since the movements which lacked reasonableness were short movements, we decided to research a possible length of about five weeks. The result is the heavy line in Fig. 6.9.

Now when we arrive at a single set of values for a cycle, the shorter the length of the moving total involved, the more cyclical values are retained in the filter. That is, the two-week cycle reflects not only short movements in the market but also picks up pieces of all the larger cycles. The moving total of five days, which defines the two-week cycle, eliminates all cycles of five days in length and most of the smaller cycles but retains values from all cycles which are larger. The moving total for the 221-week cycle, on the other hand, eliminates all cycles of two-year lengths, and most of all smaller cycles, but retains elements of all larger cycles. The small cycles, then, reflect not only values close to their own length but also an amalgam of all larger values, so that the small cycle curves reflect at once both long and small cycles—just like an egg reflects an adult chicken. For instance, in the track of the 10-week cycle in Fig. 6.9, we can see elements of the 78-week cycle which troughed in the third quarter of 1969, peaked in the first quarter of 1970 and troughed in mid-1970. When we look at the short-cycle picture, then, we must keep in mind that the longer cycles are also present—not exactly, but in broad movements.

In Fig. 6.9, we can see that in the final six months of 1969, GM moved with the five-week cycle, and the other two short cycles as well, since the stock responded by moving sideways with the cycle in the third quarter and moved down with the cycle in the fourth quarter. It rallied late in 1969 with the cycle, troughed with the cycle in early 1970, rallied again (with the 78-week cycle at the end of the first quarter) and finally declined to the 1970 low of the long cycles. The final movement to the 1970 low, we note, was almost entirely the result of long-cycle pull, since all of the short cycles were attempting a rally in the second quarter of 1970.

If you study the chart carefully, in connection with the chart of Fig. 6.6, you will see that most of the movements of the stock were accounted for by the movement of the six cycles. That is, the long-term swings were the result of the 221-week cycle. The intermediate swings were caused by the 78-week cycle and the swings which were lesser in time were mostly the result of the small cycles. When we wrap the whole ball of wax up into a single value—the high and low prices touched by the stock each day—we can see that most of General Motors' movements were caused by the pull of the individual cycles working as a team and also individually.



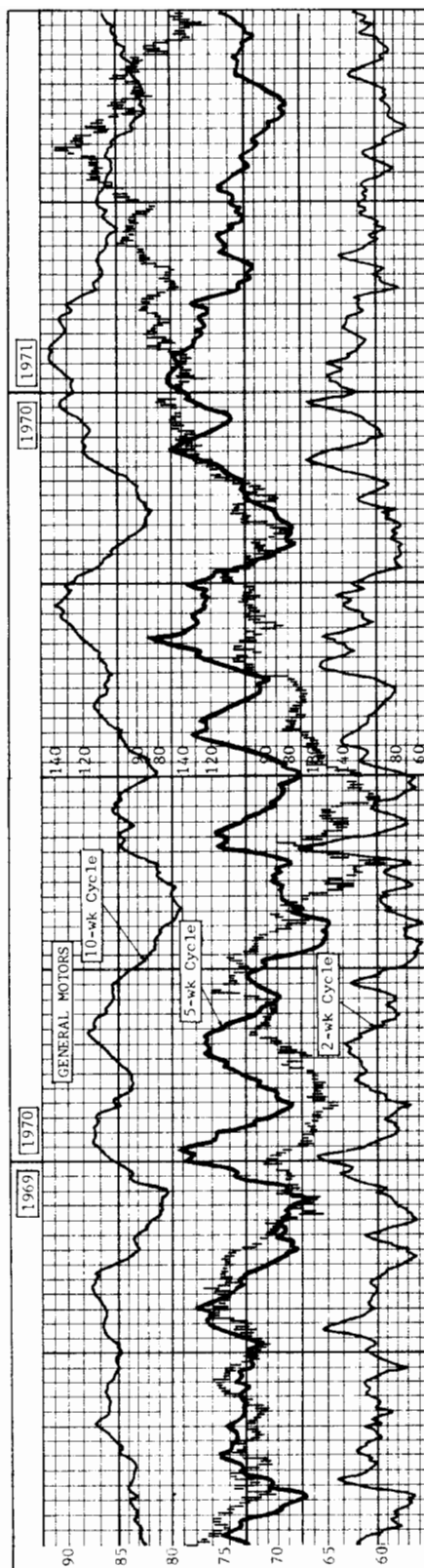

Fig. 6.9—The response of General Motors to short-cycle pull, 1969-71.

The response of Natomas to short cycles

Just to show that General Motors is not an exception, we have charted Natomas over the period used for the GM illustration. By comparing Figs. 6.5 and 6.10, we can see that the short-cycle tracks explain some of the movements of the stock not seen in the large-cycle swings.

For instance, the violent swing upward of the stock from the trough of the 78-week cycle in the third quarter of 1969 is seen as the upsurge of the five-week cycle. The sideways movement of the same time is also in keeping with the track of the five-week cycle. The rally in the third quarter of 1970 shows the movements of the big cycles but also stemmed from the powerful swing of the five-week cycle. The movement in late 1970 and early 1971 came from the combination of all the cycles, but, as we can see, the return to the 100 level by the stock in the second quarter of 1971 was largely an anti-cyclical movement.

What we are trying to point out, especially in this illustration, is that stocks move not only because of cycles but also because of developments which affect that stock, or its group of stocks, while largely leaving the market untouched.

Once again, the cycles which we arrive at by TORQUE analysis methods are central values, or express the broad sweep of the market. They pick up the movements of all stocks in the market and are hence responsive in two ways: (1) to the long-term swings of a majority of stocks and (2) to the short-term swings of a bigger majority of stocks over shorter periods of time. They register the anti-cyclical movements of individual issues, such as a particular group, but they average them out, so to speak, since the movements become a part of the larger picture, and, as the picture becomes larger and larger, individuals play smaller and smaller roles in the swing of the cycles.

No cycle, regardless of length, can ever portray the movement of all stocks for the simple reason that all stocks do not move in the same direction at the same time. Even on Monday, August 16, 1971 when President Nixon's new economic policy took effect in the market and the market responded with a 32.93-point gain, there were 107 stocks which went down—as opposed to 1503 which advanced. By Tuesday, the balance had moved to 932 advances and 536 declines, and by Wednesday, the balance had swung back—1062 declines and 407 advances.

With cycles, then, we pick up two things: (1) from the long cycles, the general direction of movement—or the flow of the tides of economic affairs—and (2) from the short cycles, the wave action within the general movement—or the swing of minor events and their impact on the longer, more important movements.

For this reason, we must be interested not only in the short swings of stocks but also the long swings. For maximum profit we must know the long-term psychology of the market, but we must also be aware of the short-term psychology (both equated with volume, or “put your money where your mouth is” reality), since the long-term movements begin with short-term swings and the success of a long-term movement is directly related to the support given the long-term by the short-term, and vice-versa. This is especially true when a stock begins an anti-cyclical move. So long as the stock



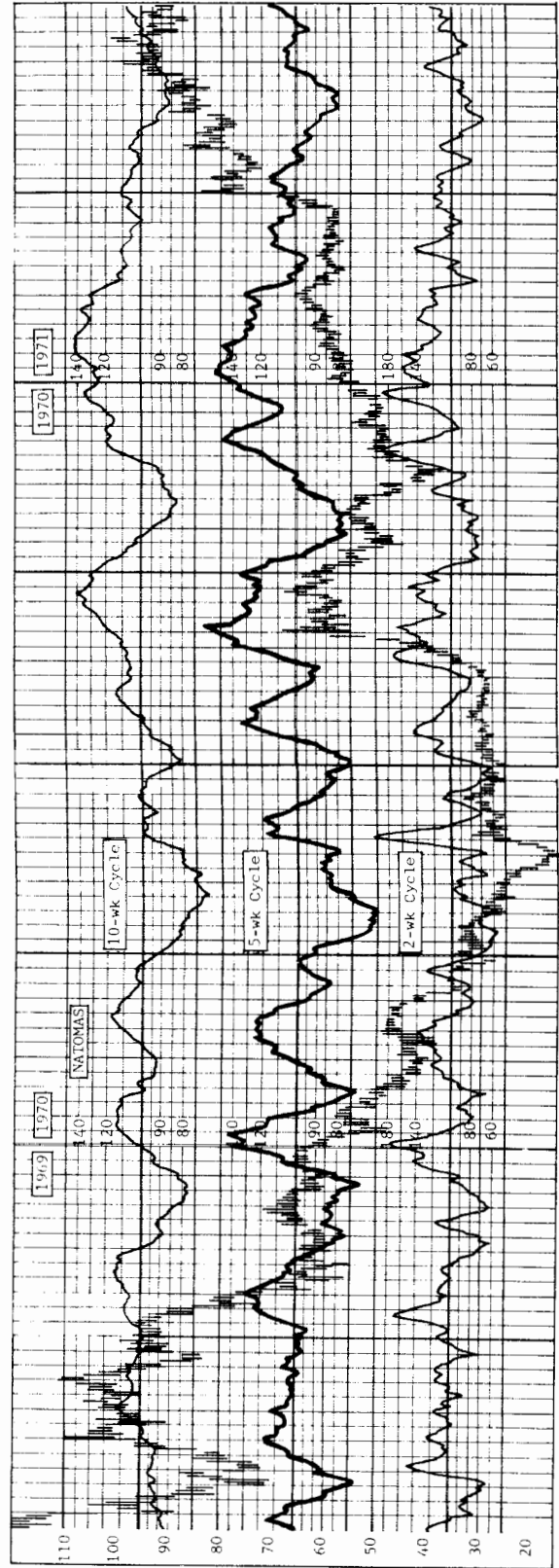

Fig. 6.10—The response of Natomas to short-cycle pull, 1969–71.

is moving in your direction, hold on—but be alert for the day it begins to revert to cyclical influence.

IV—Cycles Provide Perspective for Market Decisions

The important thing in the market is to be right—not necessarily 100% right but near enough to profit from the swing of the cycles—and perspective is the main ingredient in a correct decision. For instance, a man shopper in a grocery store probably doesn't know whether tomatoes are high or cheap, but a woman probably does because she has the perspective acquired from previous swings of tomato prices.

With cycles, when we have accumulated data or inspected a long-range chart, we can acquire perspective if we relate the swings in price of a stock with the cycles. For instance, if a stock is selling at a price about equal to its low at the last trough of the 4¼-year cycle—and we know that the 4¼-year cycle is ready to start up—we know that the stock is “cheap.”

By the same token, if a stock is selling at about the same price it sold at the last peak of the cycle, and we know that the cycle is peaking, we know that the stock is “high” from a cyclical standpoint—or is better sold than bought.

Now even with cyclical perspective, the mathematical odds of turning a profit from a stock are only 50-50. That is, in the final analysis, we will have either a gain or a loss, but, if we use our heads, we can improve these mathematical odds. First of all, assuming we are buying at a cyclical low, we know that an upswing of the cycle will give us a better chance for profit than if we buy at other times, since we can attribute a large portion of a stock's movement to a cyclical swing of a long cycle. Second, we can add to the 50-50 odds by picking a stock with good fundamentals. This kind of stock is likely to outperform one with poor fundamentals, even though we must recognize that predicting fundamentals into the future is also subject to odds.

Third, we can further add to the chances for success by observing the technical movement of the stock, since stocks move not by cycles and fundamentals alone but also tend to move in technical patterns. That is, when a technical pattern has begun, the odds are better than 50-50 that the pattern will fulfill with or without cyclical assistance, as we shall see.

To be successful in the market, then, we need to understand that a stock with good fundamentals is a better buy than one without, that a stock which acts well technically is more likely to give us profits than one which doesn't and, thirdly, we need to know enough about cycles to know where they are in their development—or how near they are to the end of a swing. If we plant seeds of corn in the spring of the annual cycle, the odds of harvesting cobs of corn in the fall are much better than if we plant in the summer or fall months. All other considerations being equal, then, cyclical perspective is the ingredient most likely to give us maximum profits.

The effect of cycles on a stock with declining fundamentals

A combination of declining cycles and declining fundamentals can only result in a declining stock. A combination of rising cycles and improving fundamentals can



only result in a rising stock. When the combination is not present—or when one factor is in opposition with the other—the stock will either hold steady in price if the factors are balanced or move in the direction of whichever pull is the stronger at the moment.

To illustrate this premise, we have drawn two daily charts, one of Boeing in the 1968–70 downswing when Boeing's earnings were deteriorating, and the other of an electrical connector company, AMP, Inc., in the 1970–72 upswing, when AMP's earnings at first declined somewhat but then took a turn for the better. For perspective into the pull of cycles on stocks in these two opposite cyclical situations, we have overlaid the stocks' price patterns with tracks of the six cycles we have uncovered in the market's movements.

To begin with, let's take a look at Fig. 6.11, which is a 12-year chart of Boeing. Boeing started its rise a year after the troughing of the 4¼-year cycle in 1962, with a change in its earnings picture, and climbed from an adjusted low of about 15 to reach a high, in 1966, of more than 90. From here the stock declined with the cycles to a low of 40 at the trough of the 4¼-year cycle in the same year—this despite earnings which held at a high level until the third quarter of the year.

From this 1966 low, the stock rebounded, on declining earnings, to a high of better than 110 and then started down towards its 1970 low of 12 at the trough of the 4¼-year cycle.

In Fig. 6.12, we show, on a daily basis, part of the stock's decline, beginning in July 1968. At this time, the stock was nearly \$70 but declined to a low of about 52½ with the 25-week cycle, spurted back to 64 with the small cycles at the beginning of the fourth quarter of 1968 and declined with the small cycles back to the 52½ level in mid-quarter. A fast run near the end of the quarter was the stock's response to an upswing of all the cycles and the peak of the 4¼-year cycle, and, from here, the stock mostly drifted sideways until the cycles really began to take hold in the middle of the first quarter of 1969.

The decline which began here brought the stock down to a low of 30 in the third quarter of 1969, and, from this point, the stock rallied somewhat, getting back to nearly 38. From this peak, the price was mostly within the narrow range until the middle of the fourth quarter of 1969. From here, the stock began to swing more noticeably in concurrence with the 25-week cycle, even though its drift was still downward, making rallies and declines with the cycle.

Overall, we can see that the movement was mostly coordinated with the 4¼-year cycle, and, in the first year, with the 78-week cycle. When it failed to rally with this cycle in late 1969–70, it reverted to shorter-length cycles for support, settling for movement first with the 25-week cycle and, in the final stages, for movement with the five-week cycle.

Boeing, all during the downswing illustrated, was a "sick" stock. As we can see from Fig. 6.11, earnings were declining, except for the final months of 1968, and, from a fundamental standpoint, there was little to attract one to make a purchase—yet somebody did at every cyclical low. That is, since the stock advanced from the small cycle lows, some buyers had to be aggressive enough to buy the stock. Cycle troughs have



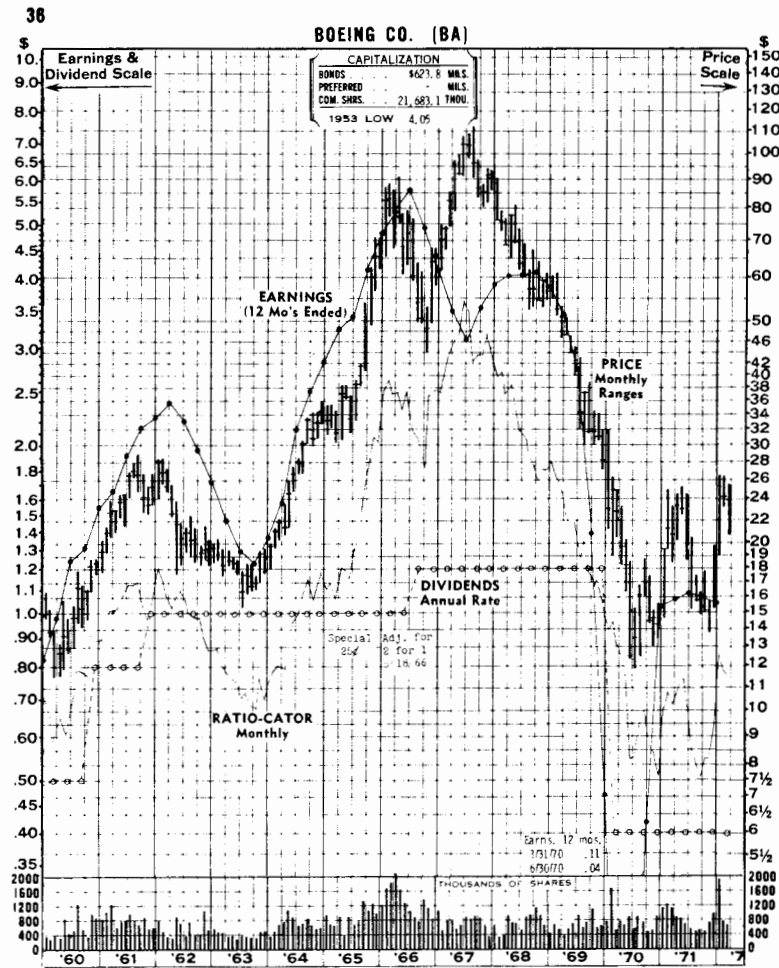

Fig. 6.11—The 12-year picture of Boeing's response to the cycles.

great attraction, even in a deteriorating situation, if there is nothing at hand to give you perspective.

The main point of the illustration, however, is to show you that a weak stock, in a cyclical downpull, will get weaker and weaker—so long as the cycles are pulling down. We can also see, as the stock got weaker and lower in price, that its response was made to smaller and smaller cycles. That is, the stock is a good example of the breakdown of long rhythms into shorter and shorter components as the market deteriorates. This, of course, is only one stock, but if you look at a chartbook for the period and compare price movements with the cycles portrayed in Fig. 6.12, you will see that other stocks also showed less and less response to longer cycles as the downturn continued.

We also can see another point in the illustration. Most traders like to “short”

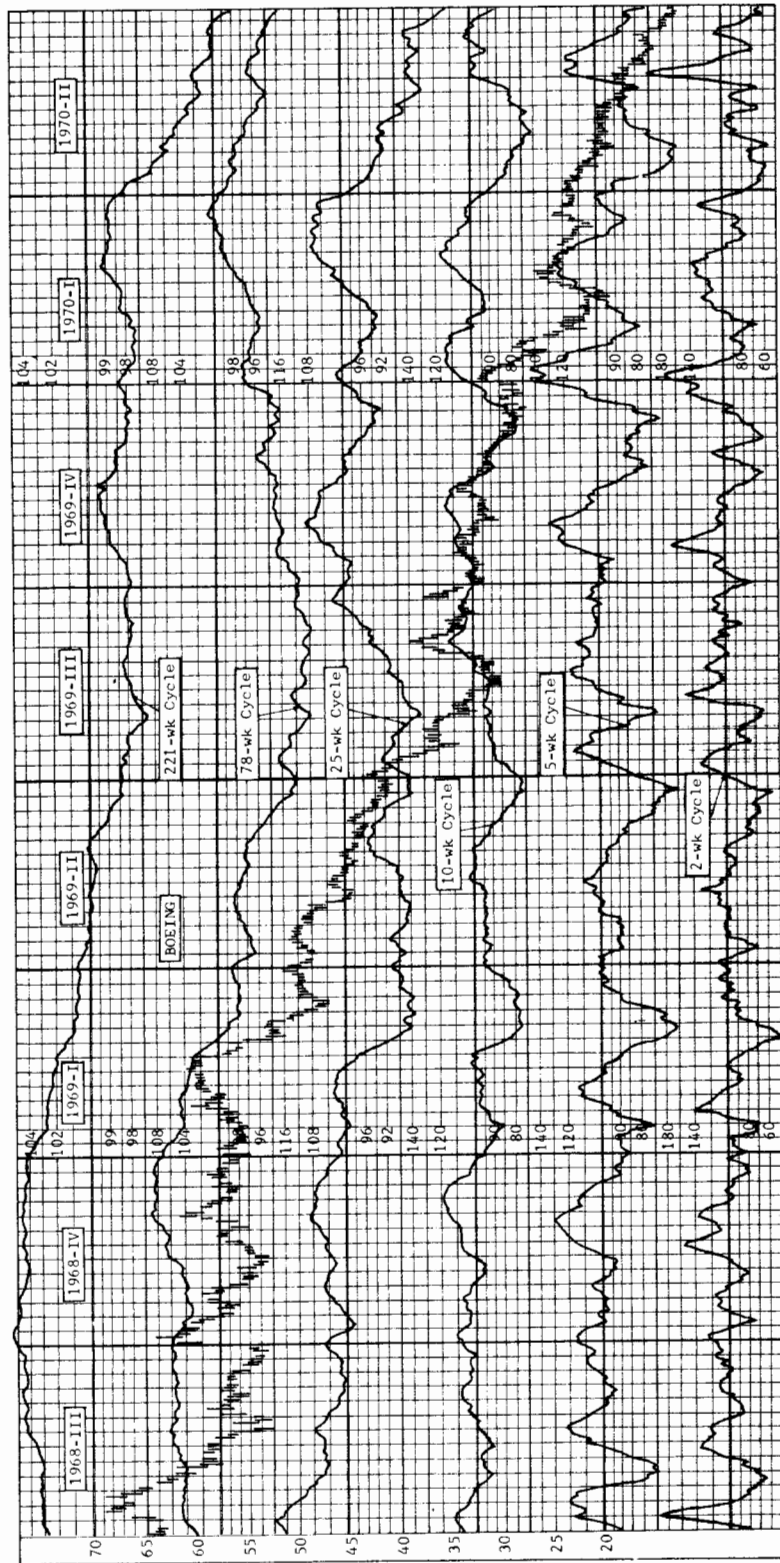

Fig. 6.12—Boeing's response to all six cycles in the 1968-70 downswing of the market.

stocks which are strong. That is, when a stock has made a 10-point run, say, they like to sell it in hopes of a quick pullback in price. When they are right, they get short, quick profits—but, on the other hand, shorting a weak stock at a long-cycle peak is much more rewarding.

So long as the long cycles are providing a downward trend for the short cycles, and as the short cycles become more and more an influence on the stock, there is generally little to fear until the long-cycle trough. From there, of course, it is a whole new ballgame, since the whole cyclical field will become synchronized and the process will reverse—stocks will begin to respond to longer cycles, working their way back up the chord. At some point, however, the short cycles will again become the dominant force in the stock, and shortly thereafter (in long-cycle time) the long cycles will turn.

The effect of cycles on a stock with good fundamentals

The other side of the coin is visible in Fig. 6.13, which is a long-term picture of AMP, Inc., a maker of solderless electrical connectors. As we can see, the long cycles have had only a minor effect on AMP since the stock dropped back from its upward trend only briefly at the 4¼-year cyclical lows. It declined from \$30 to \$22 at the 1966 low and from \$60 to \$41 at the 1970 low, so it was not immune to cyclical down-pull but, with its long fundamental trend pulling up, the cyclical pull was minimized.

To illustrate what can happen when a stock of this sort troughs with the 4¼-year cycle and starts upward, we have drawn Fig. 6.14, which is the same daily-basis chart with all six cycles overlaid on the price pattern.

Now we can see that AMP is not really immune to cycles and that it makes its major movements in harmony with the 78-week cycle. That is, from the 1970 low, the stock tended upward until early 1971, and, from there, down to the November 1971 low of the cycle. The stock can also be seen to be in sympathy with other cycles, particularly the five-week cycle, since, at nearly every trough of the five-week cycle, the price of AMP also troughed. It was not in harmony with the five-week cycle all the way, however, since the stock continued strong for about a quarter-year after the five-week cycle topped out in early 1971. Nevertheless, it still answered the troughs of the cycle, even though, overall, it was in disagreement.

This points up something we have previously tried to explain. You not only have to watch the cycles, but you have to watch your stock's reaction to cycles, since individual stocks are subject to more than cyclical influence, as we can see. We cannot rely simply on a long cycle to pull a stock along with it, since the short cycles also have an effect. This is the result of the divergence principle we discussed earlier. That is, when a genuine clock-setting trough of the cycles is reached, all cycles are in harmony at first. One by one, however, the shorter cycles begin to pull back towards a new trough while the long cycles are continuing to pull upward toward their peaks. The cycles are in opposition, and, while the short cycles may be diverted from troughing for a while, sooner or later they are going to get the job done, and some stocks are going to go with the short cycles.

Now the recoil of a cycle from its peak, as for instance the recoil of the 25-week cycle in the fourth quarter of 1970, isn't just a coincidence. The cycle is reflecting the



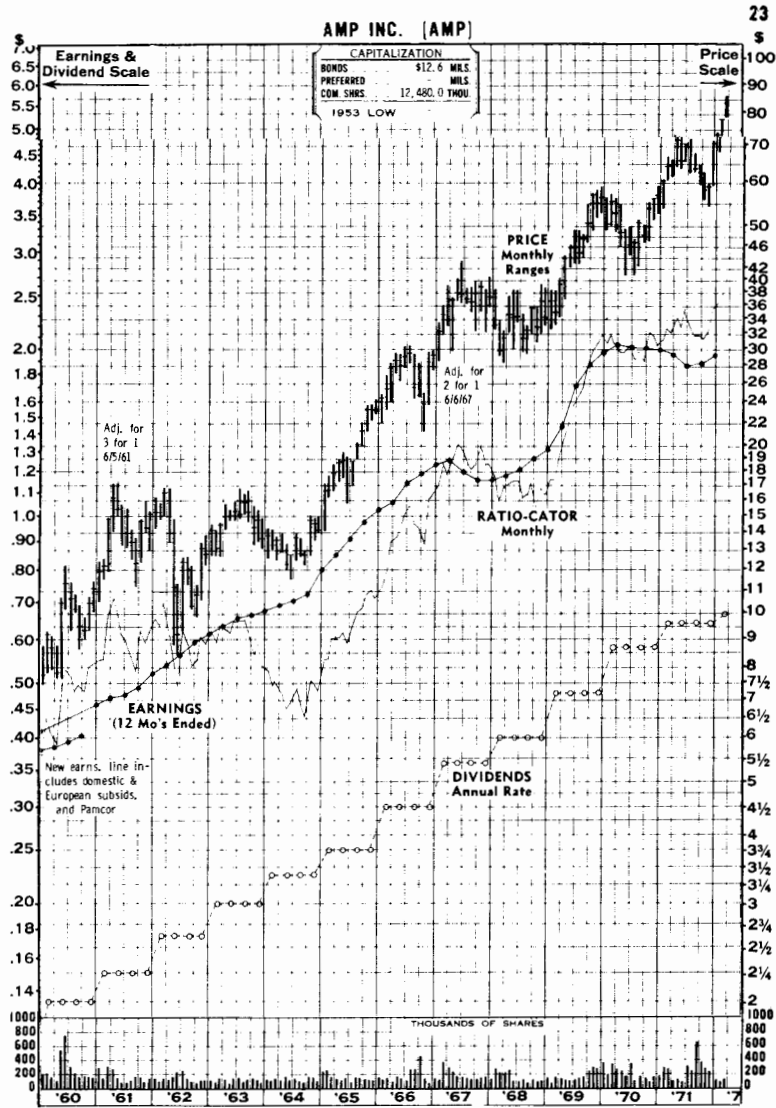

Fig. 6.13—The 12-year picture of AMP, Inc.'s response to the cycles.

lessened input figures versus the big outgo figures (which previously went into the moving total). Since some of the lessening input is due to certain stocks declining instead of advancing, it follows that there are fewer stocks advancing when the short cycles are recoiling. Since we do not know which stocks are declining, except by watching individual stocks, it follows that we had better keep a weather eye out for our holdings when the cycles begin their divergences.

Some stocks are going to decline since they literally run out of buyers—or the balance of buying and selling the stock begins to swing back to selling—as the price of the stock reaches higher levels. So long as the stock maintains the integrity of previous

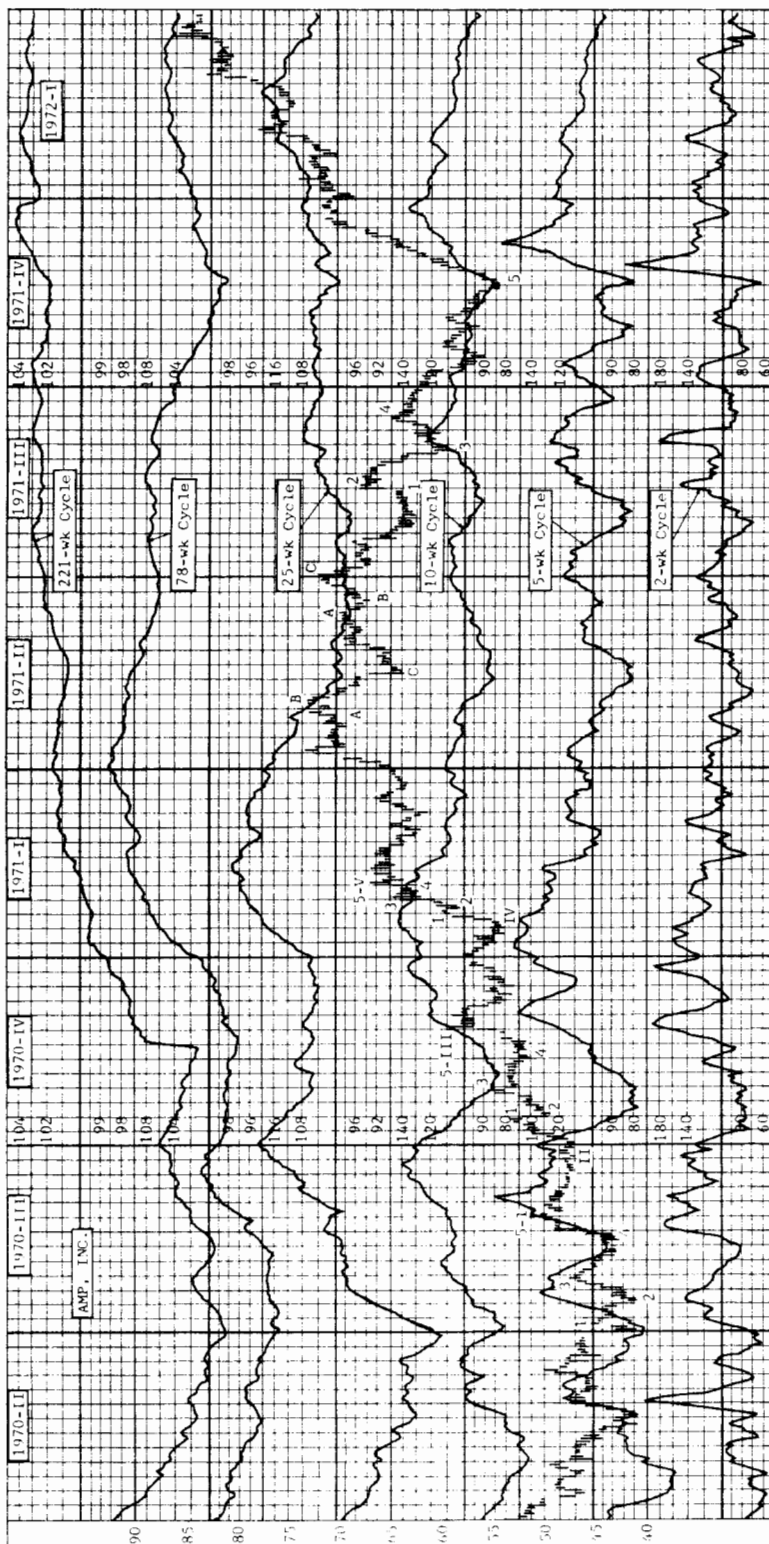

Fig. 6.14—AMP's response to all six cycles in the 1970–72 upswing of the market.

lows, however, it is most likely in little danger as it pulls back. Technicians have a rule which says that a stock may decline as much as 66% from a high, but it is still likely to again increase in price unless it violates the limits of the pullback. That is, a thrust may carry a stock five points, while a recoil in the normal manner may pull it back three points. If the recoil stops there, it is likely that the next thrust will push the stock above its old high and into new territory.

Now when we can correlate these technical movements with cycles, we can see that we have additional perspective into what to expect from a stock, since, when the cycle turns, it should start upward with the next thrust. In any event, we know that it is wise to watch your stocks when cycles are recoiling and interpret a stock's movements in the light of cycles.

The relationship of cycles and the Elliott Wave Principle

This book resulted from a chain of events which began in 1962 when we were first introduced to the mysteries of the Elliott Wave Principle, which had been espoused some 30 years previous by the late R. N. Elliott. Of all the methods of stock prediction with which we were acquainted at the time, Elliott's "wave" theory made the most sense, because, as we soon saw, stocks did tend to follow the basic patterns Elliott had laid out.

For instance, Elliott's basic movement consists of five legs upward and three down. The five movements include three thrusts and two recoils; the three down movements include two downward thrusts and a recoil against the downward movements. In looking at charts of price movements, we can see that stocks do move in this fashion much of the time, as do the popular averages.

The intriguing part of Elliott's theory, however, was his separation of larger corrective movements into a secondary category. These were defined as flats and zigzags, depending largely for a name upon whether the second top reached the general level of the first top, in which case the movement was called a flat, or whether the second top failed to reach, or exceeded, the first top, in which case the movement was called a zigzag. From both of these formations, Elliott called for a five-legged movement down—the basic movement in reverse—from the second top.

In studying Elliott's patterns of movement, and trying to predict from the patterns, however, it soon became obvious that the patterns did not always fulfill their prospect. The rules were too rigid, and, by the time I was introduced to the theory, the rules had multiplied into a confusing array of exceptions. In 1963, however, BCA Distributors,* reproduced from the original magazine file of *Financial World*, the articles Elliott wrote for that magazine in 1939. The simplicity of the original theory, despite its rigidity, has appeal and makes good sense.

Since we had also embarked on the beginnings of cyclical study, it occurred to us that (1) Elliott's theory was really a cyclical theory and (2) if we could understand cycles, we could probably understand why Elliott's patterns were not more reliable in their forecasts. The result of our research was (1) this book and (2) the premise that

* BCA Distributors Ltd., 1245 Sherbrooke St. West, Montreal 25, Canada.



cycles greatly enhance understanding of the Wave Principle, and vice-versa, that Elliott helps our understanding of cycles.

The reason for this probably is that it is impossible to follow all the cycles in the market. We can only follow the ones which seem to have the most impact on the market and individual stocks and weed out all the others. This process is aided by the filtering action inherent in moving totals in which the total cuts off nearly all lesser cycles and retains nearly all larger cycles, so that the smaller cycles are always a mixture of big and little cycles.

The Elliott Wave Principle, we believe, works because it reflects not only the principle waves, but also it picks up the smaller movements and the combination of movements of all cycles. It fails largely because it neglects to take volume into consideration and because, over the years, the rules have become too rigid and too filled with exceptions. If you add volume to Elliott's work, his patterns become clearer and more easily understood.

In Fig. 6.14, we have placed an Elliott "count" on the chart of AMP. As we can see, the movement from the July 1970 trough was contained in five large movements (Roman numerals), which, in turn, contained five small movements. After the end of the final leg, the stock moved up to form the first peak of an Elliott flat in the second quarter of 1971, and, after the second peak of the flat at the beginning of the third quarter, moved down to the trough of the 78-week cycle in a series of five downward legs.

In this chapter we have attempted to give you some pointers on how to make cycles work for you. Cycles are not something you can learn about by reading, however, since cycles require doing. It takes experience to learn all the tricks, and, even then, there are always more things to learn. The only way to learn is by doing.

Even if you avoid cycle analysis, however, we hope you have learned something about the market from this book. At the very least, you should be aware that (1) there are times to buy and times to sell stocks and (2) even a glance at a long-term chart will now give you an indication of whether the stock you have in mind is selling at a high price or a low one. Look before you leap, not on the way down. Stocks do not come equipped with parachutes.



A

Advance-decline figures, 136–137
 Advances totals, 150–152
 American Electric Power, 227–228, 229
 American Hospital Supply, 211, 212, 213, 214
 American President Lines, 222
 American Telephone and Telegraph, 204
 AMP, 236, 239
 Amplitude, cyclical swings, 68–69, 138, 174, 180, 181
 Angle of cyclical vector, 106–107
 August, 118, 119, 121
 Axes, two, 175–176

B

Balances, underlying, 124–125
 Bangor Punta, 219
 Bargain or “oversold” area, 178
 BCA Distributors, 242
 Berkey Photo, 219
 Beta factor, 111
 Boeing, 236, 237, 238
 Bull market, 69–71 (*see also* Volume forces)
 Buy-and-hold, 171
 Buy-sell totals, 138
 Buying and selling volume, 131–133
 Buying, bulk, 179
 Buying volume, 100

C

Calendarization, 215
 “Catch-up,” 70
 Chart readers, 181
 Chartists, 181
 Charts, daily and weekly, 181
 Cheap stocks, 202–215
 Chrysler, 217, 218
 Circular shape of cycle, 175
 Closing price, 130
 Commonality principle, 150, 208
 Commonwealth Edison, 211, 214
 Continental Airline, 219, 220
 Control Data, 218, 220, 222
 Convergence, 209, 211
 Crashes, 118–119
 Credibility, 207

$$\text{Cycle} = \frac{\text{Price}}{\text{Volume}}, 125$$
 Cycles:
 angle from horizontal, 93
 balance of force between thrust and recoil, 93
 beta factor, 111
 characteristics and properties of Fibonacci series, 84–85
 cycle response ($1 \div \text{sine}$), 93
 cyclical analysis, 111–112
 double, 99
 Fibonacci (σ) additive-portable value, 88–90



Cycles (*cont'd.*)

- Fibonacci ratio-sum of square, thrust and phi (ϕ) additive, 87–88
- Fibonacci values control growth, 92–94
- Fibonacci from movement of axis of circle, 86
- forces and framework, 61–95
- fundamental analysis theory of intrinsic value, 111
- fundamentals, 206–207, 235–237, 239–240, 242
- genesis, 25–32
 - exhaustion of impulse force, 27–28
 - interim movements, 28
 - intra-day cyclical movements in individual stocks, 29
 - recoil movements, 27–28
 - shift from dominance of cyclical force, 28
 - simultaneous individual moves, 29–30, 32
 - tick-rhythm breakout, 26–27
 - tick-rhythm of opposed forces, 26
- Golden Number, 95
- harmonic nature, 32–44
 - cyclical principle, 42–43
 - discordant situations, 43–44
 - future, 42
 - harmonic-length cycles, 32–34
 - how cycles combine, 37–38
- invisible mechanism, 82–95
- lengths, 143–144
- longer rhythms, 34–37
 - synthesize five cycles into one market pattern, 38–41
 - understanding cyclical system, 41–42
- measure of risk, 111
- mechanics of thrust and recoil, 90–92
- movement because of thrust against circumference, 83–84
- movements of small vs. large, 168–169
- profit, 201–243 (*see also* Profit)
- ratio to central value, 93
- response to tangential ratio of opposing forces, 93
- seasonals, 117–121 (*see also* Seasonals)
- Secrets of the Great Pyramid*, 94–95
- sine value of balance, 93
- synthesis, 44–60
 - business history divided into logical epochs, 49–50
 - discordant period prior to 1932, 44–45
 - 8.5-year cycle, a double 4.25-year cycle, 55, 57
 - five-cycle synthesis matches weakness in DJI, 53, 55
 - longer cycles break down into shorter lengths, 50, 52–53
 - 1928–32 period, 53
 - 1932–66 periods of 17-year cycle, 45, 47
 - positioning five-cycle synthesis correctly, 57, 59
 - price cycles in market, 49
 - timing for future probable events, 59–60
 - tangent value of balance, 93

Cycles (*cont'd.*)

- technical analysis theory of repetition, 111
- theory of random walk, 111, 113–117 (*see also* Random events)
- trigonometry of square and rectangle, 85
- vectors, 106–110 (*see also* Vectors)
- volume forces, 61–82, 97–106 (*see also* Volume forces)
- Cyclical stock, 211
- Cyclical Strength = $\frac{\text{Price Movement}}{\text{Volume Balance}}$, 142

D

- Daily trend, 130
- Decisions, 203, 235–243
- Declining fundamentals, 235–237, 239
- Diameter, 126–127
- Differential gearing, 102
- Discordant situations, 43–44, 44–45
- Disharmony phase, 179, 180, 185
- Divergency principle, 209, 211, 213
- Double cycles, 99
- Dow theory, 201
- Downswings, 152–153

E

- Ego, 215
- Elasticity, 114–117
- Elliott Wave Principle, 201, 242, 243
- Employment Act of 1946, 204
- End-formed moving totals, 145–146
- Epicycles, 102–106
- Equiangular spirals, 85
- “Expanding top,” 72
- Extrapolation, 179
- Extrusion, 179, 189–181

F

- Fashion, 64
- February, 118, 119, 121
- Fibonacci grid, 87, 175–177
- Fibonacci, Leonardo Bigollo, 84
- Fibonacci series:
 - characteristics and properties, 84–85
 - growth of a cycle, 92–94
 - movement of axis of circle, 86–87
 - phi additive is portable value, 88–90
 - sum of square, thrust and phi additive, 87–88
- Fiction, 66
- Fidelity, 224–235
- Filtering action, 147, 150
- Financial World*, 242–243
- Fixed ratio, 154, 156
- “Flagpoles,” 107
- Flat trend, 172



Forces, underlying, 125–126

Forecasting:

- after 1929, 171
- amplitude of cycle, 181
- average length of cycle, 181
- bottoms, 171
- buy-and-hold, 171
- cycles synchronize clocks at cyclical troughs, 185–186
 - cycles synchronized by troughing of price, 185
 - effect of harmony-disharmony phases, 185
 - “ideal” or mechanical version of cycle, 185
 - longer cycles break into harmonic lengths, 185
 - longer rhythms most regular, 186
 - “peregrinations,” 185
 - rhythms of cycles within chord, 185
 - shorter rhythms least regular, 186
 - validity of cyclical bottom, 185
- cyclical synchronization, 181
- definitive value bases unnecessary, 172
- establish limits of cyclical swing, 181, 183, 184, 185
 - chart readers, 181
 - chartists, 181
 - cycle reverses or alternates, 184
 - daily and weekly charts, 181
 - downtrend reflected, 185
 - historical nature of asymptote, 184
 - 1953–57, 183
 - regular undulations resembling sine curves, 183
 - stability, 184
 - 10-week cycle, 183
 - 25-week cycle, 183
 - 78-week cycle, 183
 - 221-week cycle, 183
 - uptrend reflected, 185
 - volatility, 184
 - whole range of 1966–70 market cycle, 183
- extrusion, 189–191
- Fibonacci grid forms, 87, 175–177
- flat trend, 172
- image of new cycle, 179–180
 - amplitude or vertical distance of travel, 180
 - area between two parabola peaks, 179
 - combination of old values and new values, 180
 - criss-crossed lines in lower part of figure, 180
 - derives from peak of old one, 179–180
 - effort to prevent troughing, 179
 - effort to trough at regular time interval, 179
 - extruded values, 179
 - input, 180
 - input exceeds outgo, 180
 - input minus outgo, 180
 - length or timespan of cycle, 180
 - nadir, 179
 - number values added into cyclical sum, 180

Forecasting (*cont'd.*)

- outgo exceeds input, 180
- periods of disharmony, 179
- periods of harmony, 179
- possibilities during disharmonic phase, 180
- short cycles dominant in first half of disharmony phase, 180
- timespan quite regular, 180
- key, 181
- lag in moving advances totals, 186, 187, 189
- level-to-downward trend, 171
- mastering technique, 172
- mature cycle as closed system of influence, 177–178
 - area of influence between axes 0 and 1, 177
 - center of cycle-to-be, 177
 - determines resultant cycle, 177
 - downward arcs of influence, 177
 - end of first cycle, 177
 - movement beyond span of cycle, 177
 - origin of second cycle, 177
 - reversal point of cyclical influence, 178
 - upward arcs, beginning, 177
- moving total values, 189–190
 - 1949 low, 17
 - 1949–1966 swing, 172
 - 1966 high, 171
- placement of first trough of cycle, 181
- post-1966 market, 171
- price cycles spear down at cyclical troughs, 178–179
 - bulk of buying, 179
 - bulk of selling, 179
 - difference between price cycles and genuine cycles, 178
 - erosion of stock prices sets in, 178
 - extrapolate or project in straight line, 179
 - minus numbers or negatives, 178
 - movement of price from troughs, 178
 - no zeros in the market, 178
 - “oversold” or bargain area, 178
 - plus numbers, 178
 - point of balance of true cycles at zero, 178
 - price peaks difficult to establish, 179
 - regular undulating sine curve patterns, 178
 - top of cycle, 178
 - troughing of undulating curve, 178
- prior to 1929, 171
- prompt and independent judgments, 172
- recognizing seeds of cyclical change, 172
- rudiments, 172–180
- seven basic assumptions, 173–174
 - alter amplitude and frequency of long cycle, 174
 - alternation in dominance of opposing forces, 173
 - change in present situation, 173
 - cycles adjust quickly to change, 174



Forecasting (*cont'd.*)

- images of previous events, 173
- linked relationship of values moving through time, 173–174
- tomorrow's event result of today's forces, 173
- since 1949, 171
- succession of troughs since 1949, 171
- summary, 199–200
- technique, 180–191
- time intervals, 171–172
- time progression of trailing axis, 175–177
 - axis 1 right of center, 175
 - breakdown of upward force, 177
 - central axis dominant, 175
 - central axis reverses role in building cycle, 175
 - circular shape of cycle, 175
 - converged "stalk" of cyclical influences, 175
 - downward arcs right of center, 175
 - downward stalk as recoil, 177
 - ending of cycle, 175
 - individual differences, 175
 - relationship of radius of thrust and radius of growth, 176
 - small grid, 176
 - trailing axis moves toward center, 175
 - trailing axis passes central axis, 175
- two axes, parabolic path, 175–176
 - axis 1 is past, 175
 - axis 1 moved to axis 2, 175
 - axis 5-1' as present, 175
 - circle has one axis, 174
 - cutoff parabola with uptrend, 174
 - dispersion of initial force, 175
 - left axis moved at regular intervals toward right axis, 174
 - parabola different from circle, 174
 - parabola has two axes, 174
 - parabolic shape of market price cycles, 175
 - possibility of cyclical forecast, 175
 - restraining influence of radius 1, 174
 - shape like small end of egg, 174
 - two radii emanate from single axis, 175
- volume, 191–199
 - cyclical pattern, 196–197
 - cyclical, psychological, seasonal, 193–195
 - economics, 192–193
 - 1966–70 market, 197–199
 - seasonal pattern, 195–196
- Frequency, 174
- Fundamental analysis theory of intrinsic value, 111
- Fundamentals, 66, 206–207, 235–237, 239–240, 242
- Future markets, 204–205

G

- General Foods, 211, 212
- General Motors, 225, 227, 228, 230, 231, 233

- "Getting even," 70
- Gilbert Flexi Van, 219, 220
- Global Marine, 219, 220
- Golden Number ϕ , 94
- Golden Rectangle, 85, 86
- Gompertz, curve, 66
- Great Pyramid of Egypt, 85, 94–95
- Grid, 87, 175–177
- Growth stock, 211
- Gulf and Western, 219, 220

H

- Haloid, 207
- Harmonic lengths, 185
- Harmonic "receivers," 109–110
- Harmonic sine values, 108
- Harmony phase, 179, 185
- High stocks, 202–215
- Hurst, 150, 208

I

- IBM, 207, 218, 219
- "Ideal," 185
- Image, 173, 179–180 (*see also* Forecasting)
- Impulse force, 27–28
- Impulse waves, cyclical, 26–27
- Individual issues, 211–214
- Individual moves, simultaneous, 29–30, 32
- Individual stock volume, 135–136
- Individual stocks, 29
- Industrial stock, 225, 227
- Interim movements, 28
- International Paper, 217, 218
- Intra-day cyclical movements, individual stocks, 29
- Intrinsic value, fundamental analysis theory of, 111
- Investment (*see* Profit)

J

- Jersey, 217
- June–July lows, 119
- July, 118–121

K

- Kodak, 217, 218
- Kyklos, 82

L

- Lag:
 - moving advances totals, 146–147, 186, 187, 189
 - moving totals, 144–145
- Large cycles, 168–169, 216–218
- Length of cyclical swings, 68–69, 143–144
- Liquidity, 106



Logarithmic spirals, 85
 Long cycles, 207–208, 220, 222, 225, 227
 Losers, 70–71

M

Magnetic field, 106
 Mansville, J., 217
 “Market price delusion,” 66
 Mechanical version of cycle, 185
 Minus numbers, 178
 Movements, small cycles vs. large cycles, 168–169
 Moving advances totals, 146–147, 186, 187, 189
 Moving total:
 addition of new input numbers, 137
 compare cycle to cycle, 138
 end-formed, 145–146
 filtering action, 147, 150
 forget annual cycle, 138
 lag, 144–145
 many cycles of differing lengths, 138
 mathematical filter, 138
 net differences between thrust and recoil, 138
 should equal a cycle radius, 138–139 (*see also*
 Radius, cycle)
 subtraction of old outgo numbers, 137
 sum of numbers within total, 138
 two functions, 138
 values, 189–190

N

National Quotation Bureau, 209
 Natomas, 218, 220, 222, 224, 233, 235
 Negatives, 178
 Newton's laws, 83
 Nickel, 217
 1966–70 swing, 162, 164, 168
 1970 trough, 159, 162
 November, 121
 Numbers, minus and plus, 178

O

Omicron, 84
 Opposed forces, 127–129
 Oscillating action, 105
 “Oversold” or bargain area, 178
 OXY, 133–135

P

Parabolic path, 175–176
 Paramecium, 83
 Peregrinations, 185
 Perspective, 235–243
 Phi, 84
 Pi, 84

Plus numbers, 178
 “Pocket burn,” 66
 Price, 98, 101–102
 Price and volume, 133–135
 Price cycles, 25–60 (*see also* Cycles)
 Price movement contradictions, 130–131

$$\text{Price Movement} = \frac{\text{Advances}}{\text{Declines}}, 142$$
 Price moves, visibility, 136–137
 Price-volume relationship:
 cycles derive from balance, 157–158
 cycles revealed by, 158–169
 DJI velocity index defines, 156–157
 five cycles defined 1970 trough, 159, 162
 movement of small cycles vs. large cycles, 168–
 169
 1966–70 swing of 221-week cycle, 162, 164, 168
 not a fixed ratio, 154, 156
 Profit:
 American Electric Power, 227–228, 229
 cheap stocks, high stocks, 202–215
 clues to stocks' probabilities, 214–215
 commonality, 208–209
 convergence/divergence, 209, 211
 “decision unmaking,” 203
 declining fundamentals, 235–237, 239
 Dow theory, 201
 dynamic potential of stock market cycles, 215–224
 Elliott Wave Principle, 201, 242, 243
 Employment Act of 1946, 204
 fidelity of cycles defined by Torque analysis, 224–
 235
 Financial World, 242
 future markets, 204–205
 General Motors, 225, 227, 228, 230, 231, 233
 good fundamentals, 239–240, 242
 individual issues, 211–214
 investing, business proposition, 203–204
 large cycles, 216–218
 Natomas, 218, 220, 222, 224, 233, 235
 1966–70 swing of long cycles, 220, 222, 224
 performance of control data, 220, 222
 perspective for market decisions, 235–243
 response of General Motors to short-cycle pull,
 228, 231
 response of industrial stock to long-cycle pull,
 225, 227
 response of Natomas to short cycles, 233, 235
 response of rail stock to long-cycle pull, 227
 response of utility stock to long cycles, 227–228
 78-week cycle, 218–220
 Southern Pacific, 211, 213, 214, 227, 229
 Standard and Poor's Stock Guide, 205
 teamwork between cycles and fundamentals, 206–
 207
 trendless market, 205–206
Profit Magic of Stock Transaction Timing, 208



Q

Quantity of volume, 99–100

R

Radii, two, 126–127

Radius = $\frac{\text{Torque}}{\text{Force}}$, 125

Radius, cycle:

- accurate measurement, 139
- amount of thrust produced, 139
- amplitude of swing, 138–139
- constant, 139
- finite lengths, 139
- length for moving totals, 139
- lengths longer than, 139
- lengths shorter than, 139
- maximum swing of prices, 139
- multiples of basic cycle, 139

Railroad, 211, 229

Random events:

- beta factor, 111
- cyclical field contains and tames, 113–114
- elasticity of volume quantity contains, 114–117
- measure of risk, 111
- time series, 139, 140, 141, 142
- trendular nature, 113

“Receivers,” harmonic, 109–110

Repetition, technical analysis theory, 111

Resistance, 71, 72

Rhythms, 34–37

Risk, measure, 111

Risk/reward ratio, 216

S

Sanders, 219

Sears, 217, 218

Seasonal pattern, volume, 195–196

Seasonals:

- August, 118, 119, 121
- December, 119, 121
- February, 118, 119, 121
- March, 119, 121
- June–July lows, 119
- market crashes hit bottom in July and October, 118–119
- November, 121
- seasonal pattern in average monthly volume, 117–118
- September, 118, 119, 121
- sixth month toughest in tax-holding period, 121
- “summer rally” has disappeared, 119–121

Secrets of the Great Pyramid, 94–95

Selling bulk, 179

Selling volume, 100, 131–133

September, 118, 119, 121

Shapes, cyclical, 97–106 (*see also* Volume forces)

Short-cycle, 228, 231, 233

Sine curves, 178, 183

Small cycles, movements, 168–169

Southern Pacific, 211, 213, 214, 227, 229

Stability, 184

Standard and Poor's Stock Guide, 204

Statistics (*see* Torque analysis)

Stress, 99

Subsurface conditions, 101–102

“Summer rally,” 119–121

Support, 71, 72

Swift, 217

Swirls, 85

Synchronization, 181, 185–186

Synthesis:

- discordant period prior to 1932, 44–45
- 8.5-year cycle is double 4.25-year cycle, 55–57
- five-cycle, position correctly, 57, 59
- five-cycle synthesis matches weakness in DJI, 53, 55
- five cycles into one market pattern, 38–41
- 4.25-year cycle of 1928–32 broken down into 17-month lengths, 53
- future probable events, 59–60
- longer cycles break down into shorter lengths, 50, 52–53
- 1932–66 periods of 17-year cycle, 45, 47, 49
- reveals market's cyclical nature, 44–60
- 17-year cycle divides business history into logical epochs, 49–50

T

Technical analysis theory of repetition, 111

Technicians, 206

Three-Trend Cycli-Graphs, 209, 211, 217

Thrust, 90–92

Tick-rhythm:

- cyclical impulse waves, 26–27
- price cycles, 26

Time, 98

Time intervals, 171–172

Time series:

- cyclical or seasonal forces, 139
- daily calculation of two trends, 142
- longer the cycle, 141
- random, 139, 140, 141, 142
- related elements, 139
- 10-day cycle, 140–141
- 25-day totals, 141

Tompkins, Peter, 94–95

Torque = Force × Radius, 125, 143

Torque analysis:

- advance and decline totals move oppositely, 151



Torque analysis (*cont'd.*)

- advance-decline figures, 136–137
- $\frac{\text{Advances}}{\text{Declines}} = \text{Price Movement}$, 142
- advances totals correspond closely to Dow average, 150–152
- advantages, 126
- break volume into buying and selling volume, 132–133
- breaking individual stock volume into two totals, 135–136
- buying causes stocks to advance, 153–154
- $\frac{\text{Buying Volume}}{\text{Selling Volume}} = \text{Volume Balance}$, 142
- charted Torque statistics, 150–158
- commonality principle, 150
- cycles as yield from underlying balances, 124–125
- cyclical strength, formula, 125
- determining length of cycle, 130
- erratic-looking price movements, 130
- faults, 126
- fidelity of cycles defined, 224–235
- finding basis of cyclical forces, 129–137
- how cycles are generated, 151
- how totals operate, 151
- increased prices causes selling, 153–154
- large, fast downswings, 152–153
- long- and short-term buildups of volume, 130
- longer totals swing over longer periods, 152
- measures underlying forces, not prices, 125–126
- mechanical system which produces cycles, 128
- more stocks declining than advancing, 152
- moving total (*see* Moving total)
- 90° angle between opposite poles of diameter, 127
- numbers in time series, 139–142 (*see also* Time series)
- opposed forces of price and volume, 128
- perusal of stock chart, 130
- price and volume related, 130
- price is a liar, 123–129
- price movement contradictions, 130–131
 - daily trend, 130
 - disregard closing price, 130
 - each longer movement has only one direction, 130
 - intra-day fluctuations condensed, 131
 - measure the price movements, 130
 - net movement of average, 130
 - 1-to-1 ratio, 131
 - ratio of "travel," 131
 - stock moves upward, 130
 - stock or average is down, 130
- $\frac{\text{Price}}{\text{Volume}} = \text{Cycle}$, 125
- $\frac{\text{Price Movement}}{\text{Volume Balance}} = \text{Cyclical Strength}$, 142

Torque analysis (*cont'd.*)

- price-volume relationship, 154–169 (*see also* Price-volume relationship)
- relationship of price, 127, 128
- relationships of price and volume, 133–135
- separate buying and selling volume, 131–132
- short totals swing in short movements, 151
- statistics, 136–150
 - adjusting cycles to practical lengths, 143–144
 - amount of downward movement, 138
 - buy-sell totals, 138
 - cycle radius, 138–139 (*see also* Radius, cycle)
 - price divided by volume equals radius times force, 143
 - quantity of two types volume, 138
 - relationships between four forces, 138
 - upward movement in market prices, 138
- stocks move together, 150
- $\frac{\text{Torque}}{\text{Force}} = \text{Radius}$, 125
- $\text{Torque} = \text{Force} \times \text{Radius}$, 125, 143
- Torque factors of cycle forces, 142–143
- two cycle radii not always equal to cycle diameter, 126–127
- volume totals closely balanced, 152–153
- volume totals move differently than A-D totals, 152
- volume totals parallel each other, 152
- Trendless market, 205–206
- Trendular nature, randoms of, 113

U

- Underlying balances, 124–125
- Underlying forces, 125–126
- Undulations, 178, 183
- Utility, 211, 227–228, 229

V

- "Value," 66, 72
- Value bases, 172
- Vectors:
 - carry thrust of small cycles to big cycles, 107–109
 - "excite" the cyclical field, 106, 107
 - "flagpoles," 107
 - forcebands, 106
 - harmonic "receivers," 109
 - harmonic sine values, 108
 - high-angle, 107
 - large cycles' strength, 109
 - length, 106
 - line representing direction, 106
 - liquidity, 106
 - little amplitude of price, 107
 - measure condition of market, 110
 - measuring progress of larger cycle, 107



Vectors (*cont'd.*)

- pricebands, 107
- price movement and volume of other stocks, 107
- price-volume relationship, 106
- quantity of force representing, 106
- quantity of harmonic values in cycle, 109
- "receivers a half-phase out of sync," 109-110
- striking zone of cyclical field, 106
- transmit harmonic values which build large cycles, 107
- volume determines angle, 106-107
- when stock comes to market, 106

Visibility, price moves, 136-137

Volatility, 184

$$\text{Volume Balance} = \frac{\text{Buying Volume}}{\text{Selling Volume}}, 142$$

Volume forces:

- alter basic cyclical shapes, 97-106
- amplitude and length of cyclical swings, 68-69
- bull market, 69-71
 - as prices approach old buypoints, 70
 - buyer has option, 70
 - consistent "losers," 70-71
 - holders of stock lose hope, 70
 - largest distribution of stock from "strong" hands to "weak" ones, 70
 - losses mount and price drops, 70
 - more buyers in upward market, 70
 - not selling, 70
 - playing "catch-up," 70
 - prices below buypoints, 70
 - prices subside below buypoints, 70
 - reason seller is principal factor, 70
 - seller more important than buyer, 69-71
 - selling lower, 70
 - stock flows from buyer to seller, 70
 - volume begins to dry up, 70
 - volume rises spectacularly, 70
- buying volume expands, 100-101
 - buying in upward market, 100
 - buying volume, 100
 - DJI moves upward as volume increases, 100
 - faster than selling volume, 100
 - increasing whole volume situation, 100
 - one force expands at expense of other, 101
 - seeming imbalance of force, 100
 - selling in downward market, 100
 - selling volume, 100
 - selling volume contracts, 100
 - triangular nature of volume, 100
 - whole-volume figures, 100
- closest pricebands are strongest, 67-68
- cyclical path which price travels, 98
- epicycle, 102
- epicycles "crack whip" at market tops, 103, 105-106

Volume forces (*cont'd.*)

- chord of cycles, 103
- cyclical field similar to magnetic field, 106
- oscillating action, 105
- price parabolas and volume parabolas, 103
- whiplash effect, 103
- epicyclic arrangement of cyclical "gears," 103
- flow of volume measures buying desire, 63
- forecasting, 191-199 (*see also* Forecasting)
- from beginning of DJI, 73-74, 76, 78
- how cyclical field is formed, 63-64
- increasing force remains equal to opposite, 102-103
- market's harmonic cyclical structure, 79, 81-82
- moving volume totals reveal long and short cycles, 78-79
- nature, 61-82
- net difference between thrust and recoil, 98
- price determined, 98
- prices indicate subsurface conditions, 101-102
- quantity, 99-100
 - alterations in shape of cyclical rhythms, 100
 - double cycles, 99
 - force which powers cycles, 100
 - low-volume cycles, 100
 - price traces odd patterns, 99
 - quick thrusts, 100
 - recoil of declining volume, 100
 - slow-moving cycles, 100
 - stress, 99
 - thrust of increasing volume, 100
 - too little volume, 100
 - too much volume, 100
 - true harmonious cycle, 99
 - when volume is decreasing, 99
- recoil differs in reaction, 98
- rising prices, 103
- stock flows from seller to buyer, 62-63
- support and resistance bands and triangles, 72-73
- support and resistance forcebands, 71-72
- thrust varies, 98
- time determined, 98
- vectors, 106-110 (*see also* Vectors)
- when cycle revolves, 97
- why people pay high prices, 64, 66-67
 - fashion, 64
 - fiction, 66
 - fundamentals, 66
 - market loses value base, 67
 - "market price delusion," 66
 - "pocket burn," 66
 - present confused with future, 66
- Volume, price and, 133-135
- Volume totals, 152-153



W

Westinghouse, 217, 218
Whiplash effect, 103
Whole-volume figures, 100
Woolworth, 217, 218
World War II, 205
"Worth," 66

X

Xerox, 207, 218
Xtra, 219

Z

Zeros, market, 178
Zurn, 219, 220

